



Distributorless Ignition Systems

Distributorless ignition systems are becoming an increasingly common feature on newer import vehicles. Your first reaction to this added bit of electronic wizardry might be to throw up your hands in disgust and exclaim "Why bother, haven't cars gotten complicated enough already?"

The auto manufacturers won't be going back to

building tin lizzies any time soon, however. Technology marches on, with or without us. So set your skepticism aside for a moment as we run through some drawbacks of conventional ignition systems, eliminated with a distributorless setup. You might find that there are some pretty good reasons for making the switch to distributorless ignition.

Conventional Ignition	Distributorless Ignition
The Distributor is a power drain on the engine.	The power drain is reduced or eliminated with a crank angle sensor.
Worn distributor parts cause dwell and timing variations.	The crank angle sensor eliminates most, if not all distributor moving parts. All parts that are subject to wear are eliminated.
Mechanical and Vacuum advance controls are inaccurate.	The ECU controls timing advance directly.
Single coil ignition systems have poor coil saturation at high RPM (spark weakens as RPM increases).	Multiple coils allow longer coil saturation time between firings.
Cap and rotor wear cause increased secondary ignition resistance.	The cap and rotor are eliminated—no voltage losses.
Secondary ignition wiring breakdown occurs due to heat, cold, moisture, etc.	Secondary ignition wiring is either shortened or eliminated.
High firing voltages put an increased strain on the secondary wiring.	The shortened path between coil and spark plug allows the coil to deliver full power to the spark plug.

We're going to look at two different distributorless ignition systems, one from Nissan, and the other from Subaru. Both ignition systems are just one part of a complete engine management system. Although they're both distributorless, they each get the job done a little differently.

—By Karl Seyfert

Nissan

Nissan uses a distributorless ignition system on twin cam Pulsar and 300 ZX engines. The same system is also used on their upscale Infiniti models. This "direct" ignition system places an ignition coil directly above each platinum tipped spark plug. Secondary ignition wiring between the coils and spark plugs is completely eliminated.

Ignition timing is controlled by the ECCS system's ECU, which gets some of its decision-making information from the Crank Angle Sensor. The Crank Angle Sensor is very similar to the distributor-mounted Crank Angle Sensors used on other Nissans. But now the distributor is missing. A shutter wheel, combined with LEDs, photo diodes, and a wave forming circuit, give the ECU precise crank angle and cylinder position signals.

The ECU relays its timing decisions to the Power Transistor Unit. The Power Transistor Unit contains four separate power transistors on Pulsar engines and six on the 300 ZX—one for each cylinder. At the ECU's signal, each power transistor interrupts the ground to its matching coil's primary windings. The magnetic field collapses, and the coil fires. Nice and simple.

To wring a few extra ounces of performance out of the engine, Nissan's distributorless ignition system also includes a Knock Sensor. We're more accustomed to seeing knock sensors on turbo engines. A beefed-up head gasket and other mechanical components, combined with the Knock Sensor, allow the Pulsar engine to run a 10 to 1 compression ratio.

In spite of its high compression ratio, the Pulsar's engine won't self-destruct on regular gas. The ECU uses the Knock Sensor signal to advance the ignition timing as far as possible without harmful engine knock. High octane fuel isn't required, but if you use it, the ECU can advance the timing further for increased power output.

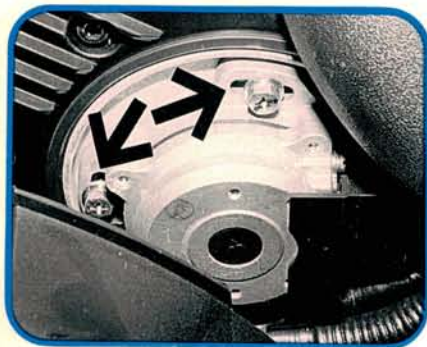

1

We'll start at the signal generating end of the Nissan ignition system. The "pancake" Crank Angle Sensor is driven by the nose of the 300 ZX's left exhaust camshaft. It's also driven by the exhaust cam on the Pulsar engine. The sensors on both engines are slotted for timing adjustments (arrows).

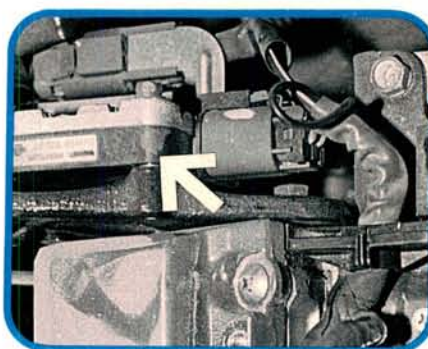

2

The Power Transistor Assembly is mounted at the rear of the camshaft housing on Pulsars (arrow), and in front of the right exhaust cam on 300 ZXs. The Power Transistor Assembly contains a separate power transistor for each ignition coil. Each power transistor gets its marching orders from the ECU.

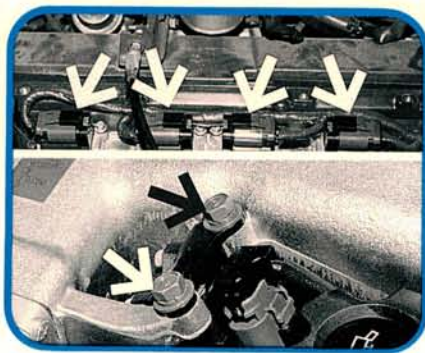

3

It takes some disassembly to reveal the ignition coils and spark plugs on the Pulsar (upper photo). They're hidden under a cover between the cam housings. Two bolts hold each coil on the 300 ZX (lower photo). A 60,000 mile spark plug replacement interval makes this job an occasional inconvenience.

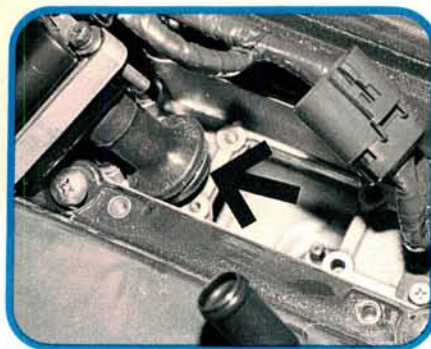

4

Maybe you're wondering, "How do I set the timing?" Well, you've got three choices. The cheapest method is to insert a short piece of secondary ignition wire between the number one coil and spark plug. Clamp your inductive timing light over the temporary plug wire and check the timing. Pretty low tech.

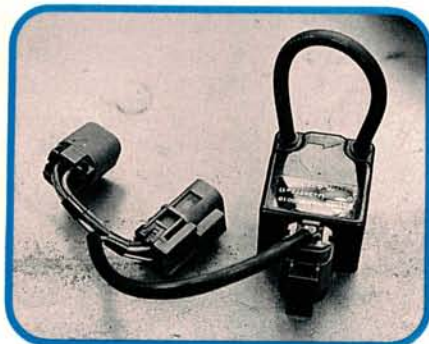

5

Our first method's biggest drawback is the amount of disassembly needed, especially on the Pulsar. A quicker answer is Kent Moore's dedicated Timing Coil. The Timing Coil connects between the Power Transistor Assembly and the number one coil to provide a temporary secondary wire for your timing light.

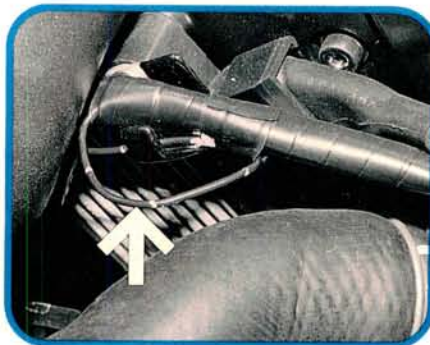

6

This wire loop at the Power Transistor Assembly is meant for an inductive tachometer hook-up. Depending on your timing light's sensitivity, you might be able to use the loop to check the timing too. Check the timing using the temporary plug wire method first. We'll need the reading later to compare timing light pickup sensitivity.



7

A sensitive timing light may pick up the power transistor's "on" signal instead of the "off" signal that fires the coil. If the light is triggered by the wrong signal at the loop, your light will blink about 15 degrees ahead of the correct reading. A cheap timing light can be an asset here.



8

Place a folded match book cover between the pickup jaws. The match book prevents the pickup's pole pieces from contacting each other, decreasing the pickup's sensitivity. With luck, your timing light will now read the "off" signal. Now compare the desensitized pickup's primary reading to your original secondary reading.

Waste Not, Want Not

The distributorless ignition system on the Subaru Legacy is our second example. Although it's new to Subaru, this type of system might be a bit more familiar to you.

The Legacy uses two coils to fire its four spark plugs. This arrangement works well with the Legacy's horizontally opposed four-cylinder engine. One coil fires the spark plugs for cylinders one and two (the front pair), while the other coil handles cylinders three and four (the rear pair). This keeps the amount of secondary wiring between the coils and the spark plugs very short.

You might have heard this setup called a waste spark ignition system (nothing derogatory intended). Each spark plug fires twice per combustion cycle; once during the compression stroke, and again during the exhaust stroke. Since there's no fuel left to burn during the exhaust stroke, the extra spark is "wasted."

The ECU relies on information from a Crank Angle and a Cam Angle Sensor. Both of these sensors use magnetic induction to generate their signals. Reluctor rings behind the crank pulley and on the back of the left camshaft pulley induce a very weak alternating current (400 mv) in each sensor, much like the pickup coil and reluctor in a conventional electronic ignition's distributor.

The Subaru distributorless ignition system also uses a piezo electric knock sensor. The ECU will advance the timing until it receives a knock signal from the sensor. The knock sensor and a 9.5 to 1 compression ratio combine to squeeze 132 horsepower out of the engine's 2.2 liter displacement.

The Legacy's ECU controls the distributorless ignition system as follows:

- Input signals from the Cam and Crank Angle Sensors keep the ECU up to date on crankshaft and piston

position. The ECU also uses Cam and Crank Angle Sensor input information to control the sequential fuel injection system.

- After evaluating all its input sensor information, the ECU sends its ignition command signals to the Ignitor Assembly.
- The Ignitor Assembly contains one power transistor for each pair of cylinders. The signals from the ECU turn the power transistors on and off.
- The collector terminal of each power transistor is connected to its matching coil negative terminal. Both positive terminals receive battery voltage.
- When the ECU turns the power transistor off, the field collapses in the ignition coil, and the spark plugs fire.

Power Balance Testing

You'll need to observe some special cautions when power balance testing the Legacy's engine. Grounding the secondary ignition to one cylinder during a power balance test can cause unburned fuel to accumulate in the exhaust system. This could cause a catalytic converter meltdown on an engine with a conventional ignition system. That's bad enough. The exhaust system damage could be even worse on the Legacy.

After you reactivate the ignition to the grounded cylinder, the spark plug will resume firing on both the compression and exhaust strokes. There's a really good chance that the spark will carry past the open exhaust valve during the exhaust stroke, ignite the left over fuel in the exhaust, and damage the exhaust system.

To safely power balance test the engine, remove the fuel injector harness to the cylinder that's being tested. This will stop the fuel supply to the cylinder and will have the same effect as disabling the ignition, without the disastrous side effects.

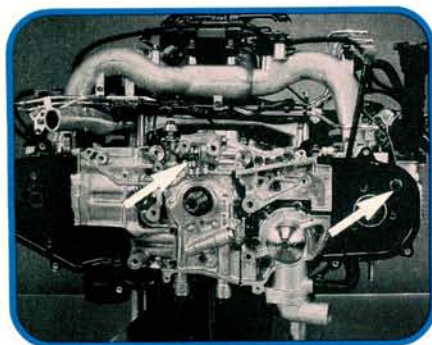

9

The Crank (left arrow) and Cam (right arrow) Angle Sensors are both visible in this shot. Magnetic induction causes the sensors to generate a weak alternating current when the engine is turning. Sensor output should be 400 mv (peak to peak) at 20 RPM for the Cam Sensor and at 40 RPM for the Crank Sensor.

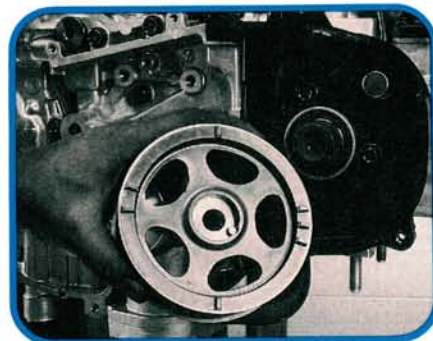

10

The Pulse Ring on the back of the cam sprocket contains four equally spaced reluctors. The reluctor spacing helps the ECU determine number one cylinder position and also which cylinder is on the firing stroke. Air gap clearance between the sensor and the pulse ring is just $0.8\text{mm} \pm 0.5\text{mm}$.

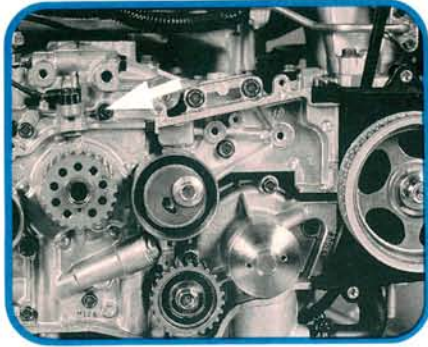

11

The Crank Angle Sensor faces the outside edge of the Crankshaft Reluctor Ring, directly behind the Crankshaft's timing belt pulley. The Reluctor Ring's teeth are spaced at angles of 10, 65, and 97 degrees. The air gap between the reluctor teeth and the Crank Angle Sensor is also $0.8\text{mm} \pm 0.5\text{mm}$.

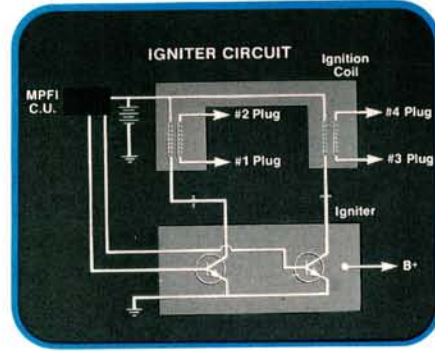

12

Both coils receive B+ voltage on one side of their primary windings. The coils fire when the ECU signals the Igniter Assembly to interrupt the coil ground circuits. The coils are actually transformers because there's no internal connection between the coil primary and secondary windings.

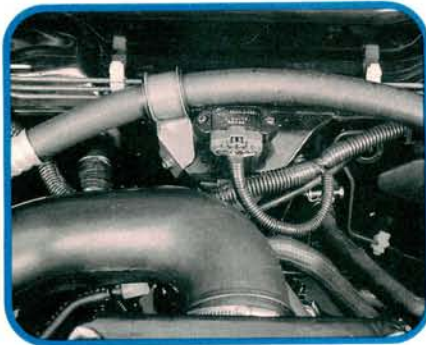

13

The Igniter Assembly is mounted above the engine, on the firewall. Two power transistors inside the Igniter Assembly control the Ignition Coils. The coils saturate when the power transistors switch "on," completing the ground circuit. The coils fire each time the Igniter relays the "off" signal from the ECU.



14

The Legacy's ignition timing is not externally adjustable. The Cam and Crank Angle Sensors are both permanently mounted. Timing is advanced to 10 degrees during starting. After start-up, the ECU uses its input sensors to control ignition timing under varying engine load and operating conditions.

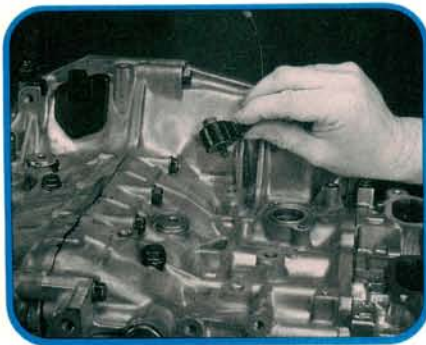

15

The piezo electric knock sensor bolts to the engine near the transmission. It's buried when the engine is assembled. Test the knock sensor operation by tapping the area around the sensor while watching the timing. Timing should retard while tapping, and return to normal advance when you stop.

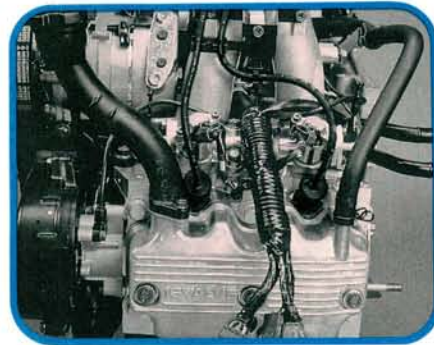

16

How do you attach an engine analyzer or oscilloscope to a direct ignition engine that has no distributor cap? Direct Ignition Adapters which translate DIS signals into raster, superimposed, and display patterns are available from several manufacturers. Temporary secondary wiring is still needed to test Nissan's DIS.