

# DRIVEABILITY CLINIC

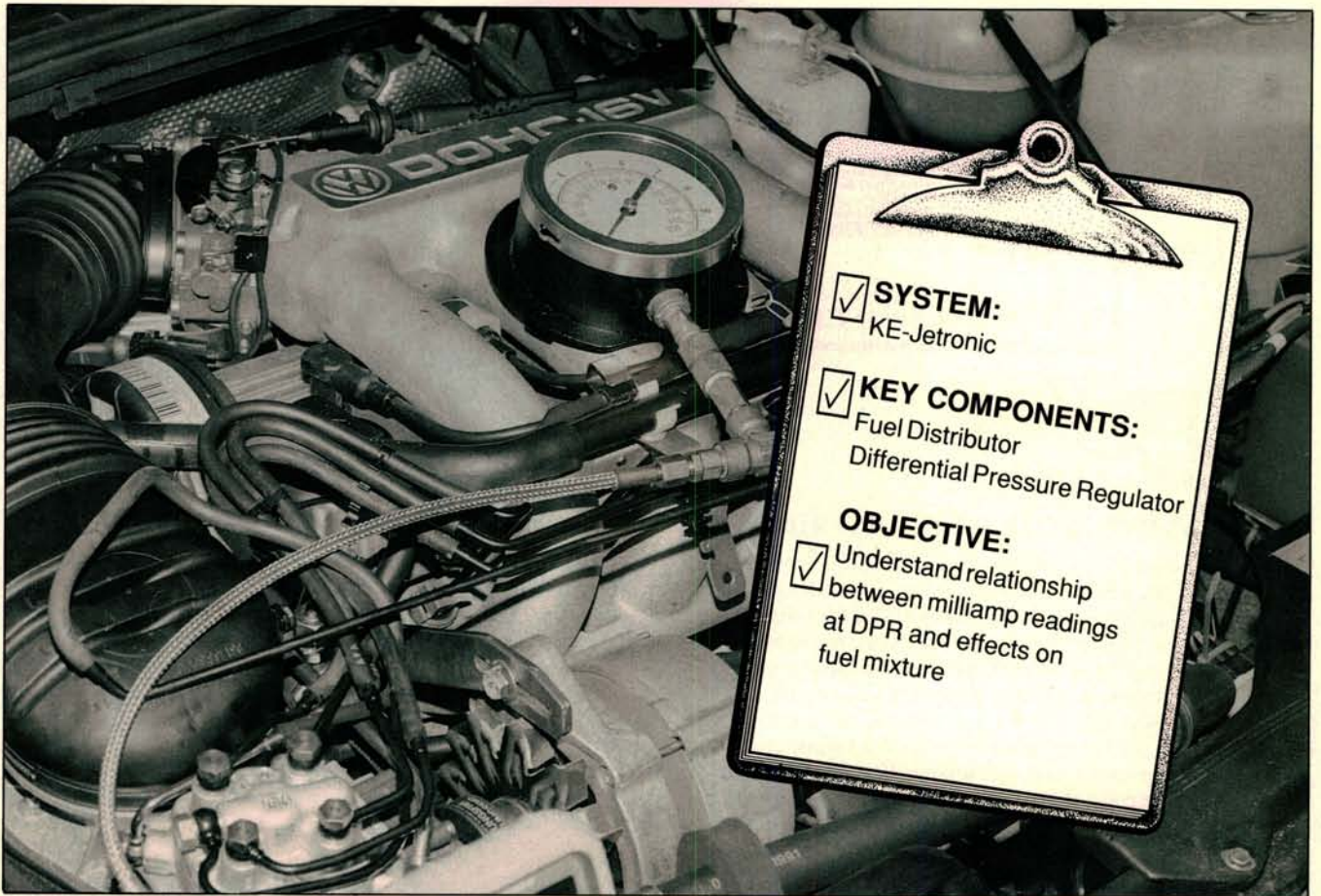

## KE-Jetronic Fuel Injection

### PART ONE

You've worked on K and K-Lambda fuel systems for years. But those darned KE-systems don't seem to play by the old rules do they? The fuel distributor is made of aluminum now. There's some strange new gizmo bolted to its side with wires attached to it. The frequency valve and control pressure regulator are both missing. What gives?

Keeping in mind that the same basic principles of operation still apply when we move from K and K-Lambda to KE, we must also note that there are major design changes between the old constant injection systems and the electronically controlled KE system. But a slight shift in thinking, and a little additional equipment will have us diagnosing and repairing these systems in short order.

This month, we'll start with a system overview, describing some major changes in design. We've included a list of different operating modes, and a description of the ways KE controls the fuel mix.

This article will be more focused, however. For now, we'll limit our study to the following:

1) Milliamp readings sent from the ECU to the Differential Pressure Regulator (DPR), and

2) How the DPR responds to those milliamps to control fuel pressure in the lower chamber of the fuel distributor, controlling fuel delivery to the injectors.

Please allow us to mention two quick cautions before we start:

- There's a lot of fuel pressure in those lines. The possibilities of fire, explosion, and personal injury have all increased as system pressures have risen.

- Please refer to the specifications for your vehicle. The tests shown are representative of this type of system, but constant redesign of the KE system, from the original Plain Jane KE to newer Motronic KE has caused changes in specs, especially for system pressure and milliamp ranges of normal operation.

Next month we'll show you basic tests of this system.



# DRIVEABILITY CLINIC

## KE-Jetronic

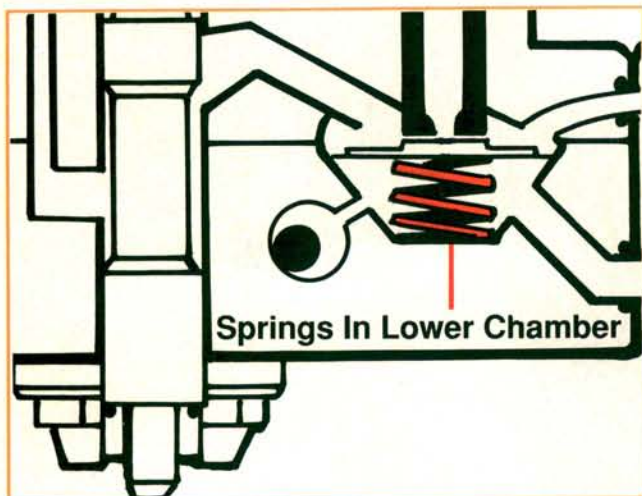

### 1 CHANGES IN THE FUEL DISTRIBUTOR

Remember our illustration of the fuel distributor in January's K-Jet article? The pressure regulating springs were located in the upper chambers of the fuel distributor on K and K-Lambda systems. But KE systems are just the opposite. The springs are located in the lower chamber now. And instead of control pressure above the control plunger, we now have system pressure. As a result, the cold start injector is now connected to the upper chamber, not the lower chamber as it was previously. Upper chamber sizes have been reduced. In fact, the entire fuel distributor is now smaller, and made of aluminum.

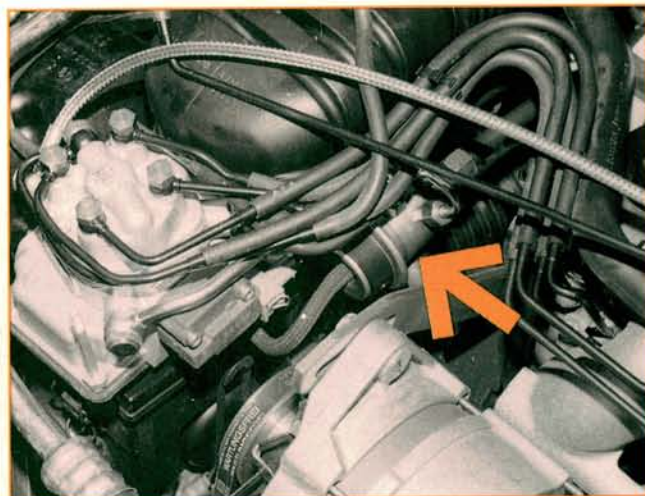

### 2 CONTROLLING SYSTEM PRESSURE

Another big change is the addition of an external pressure regulator (arrow) to maintain constant system pressure. Previously, system pressure was controlled by a pressure regulating valve inside the fuel distributor. The new pressure regulator has two other functions, acting (1) as a fuel return to the tank, and (2) as a check valve to maintain rest pressure when the pump shuts off. A quick test of the check valve is easy. Simply disconnect the fuel return line at the regulator with the fuel pump not running. There should be NO fuel coming out of the regulator with the fuel pump off—none.

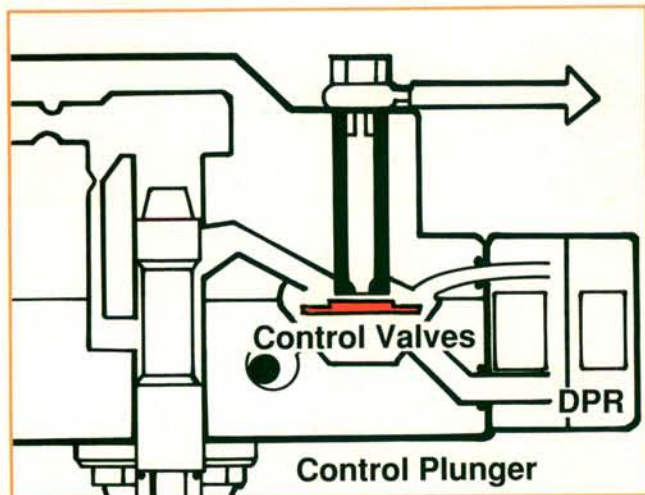

### 3 CONTROLLING FUEL DELIVERY TO THE INJECTORS

Fuel delivery to the injectors is controlled two ways: (1) The air sensor arm movement moves the control plunger as it did on previous K systems. As the plunger is pushed upward in the bore, fuel flow to the upper chamber of the fuel distributor increases. (2) Changes in Differential Pressure move the control valves in the upper chamber which feed fuel to each injector. On deceleration, these valves temporarily close the ports leading to the injectors providing a momentary deceleration fuel cut off for better emissions. We'll get to that part a little later.

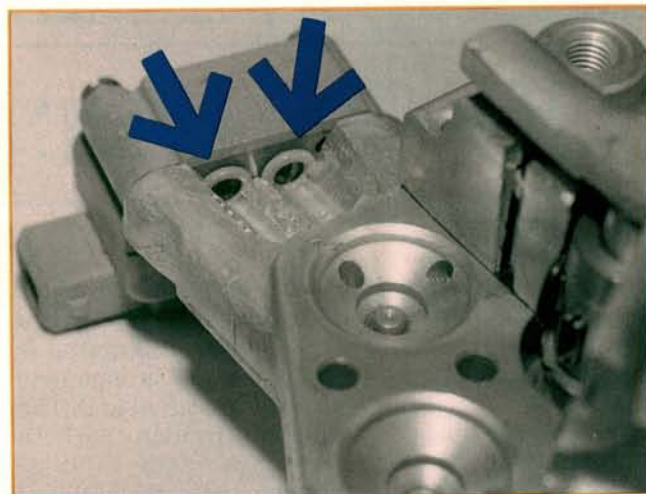

### 4 UNDERSTANDING DIFFERENTIAL PRESSURE

Differential Pressure is the difference between the pressure in the upper and lower chambers. Controlling that difference is the job of an electrically operated valve called the Differential Pressure Regulator or DPR. (Think of the DPR as a controlled fuel leak between the upper and lower chambers of the fuel distributor.) This cutaway of a fuel distributor shows the two passages (arrows) connecting upper and lower chambers through a valve in the DPR. In the next few illustrations, we'll show how changes in Differential Pressure change the fuel mixture.



# DRIVEABILITY CLINIC

## KE-Jetronic

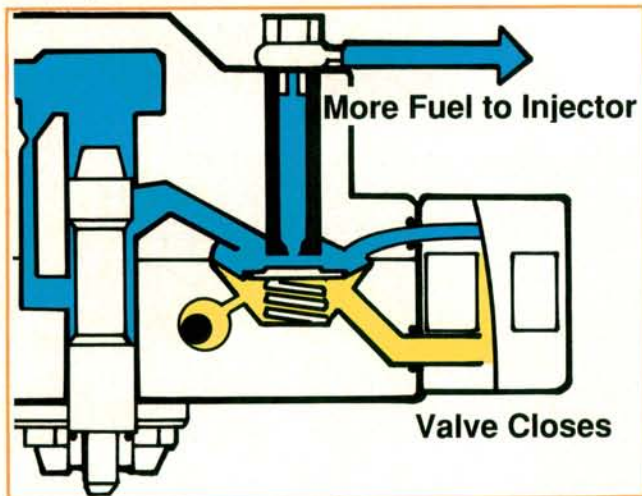

### 5 COLD START

When a cold engine first starts, the current sent to the differential pressure regulator by the control unit is high. This current pulls the valve in the DPR closed. Pressure in the upper chamber is HIGH, but with the valve closed, the pressure in the lower chamber stays LOW. The higher upper chamber pressure pushes against the springs below the pressure regulating valve. This moves the valve away from the injector port allowing more fuel to pass through to the injector. This gives us a rich mixture to get that cold engine running smoothly.

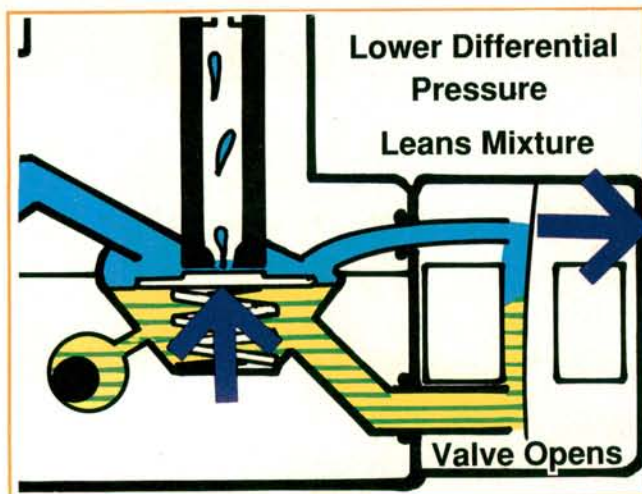

### 7 WARM UP

Remember how the old Control Pressure Regulator gradually changed control pressure to slowly lean the mixture as the engine warmed? On our KE system, a negative temperature coefficient coolant sensor informs the control unit of the engine temperature as the engine warms. Gradually, the control unit reduces current flow to the DPR. The valve in the DPR opens wider and wider, allowing more system pressure from the upper chamber to flood into the lower chamber. As the pressures equalize, the pressure regulating valves move to restrict fuel flow to the injector ports.

Minimum voltage signal

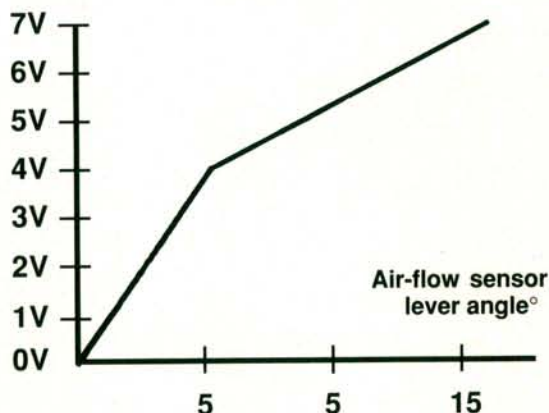

### 6 COLD ACCELERATION ENRICHMENT

During warm up, the control unit knows the engine is cold and compensates. But what about snap-throttle acceleration? We used to have an accelerator pump on carbs, and some even had an additional pump for cold operation. KE uses a potentiometer attached to the sensor arm to tell the control unit when the sensor arm moves and how far it moves. This Air Position Sensor sends a voltage signal of 0-7 volts to the control unit over a range of about 18 degrees. But our chart shows that the signal increases almost 4 volts in the first 5 degrees of travel to avoid a cold stumble.

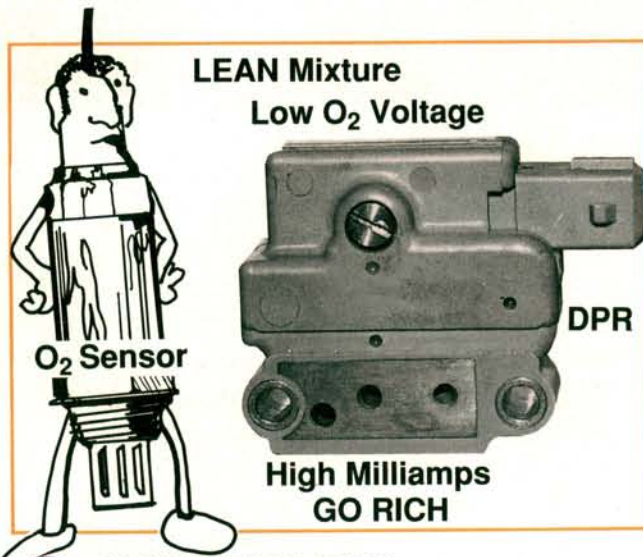

### 8 CLOSED LOOP LEAN

Now that we're all warmed up and the oxygen sensor is sending its signal to the control unit, the control unit starts to vary the milliamp electrical signal to the DPR. If the mixture is lean, LOW O<sub>2</sub> sensor voltage tells the control unit to increase current to the DPR. This is a little confusing at first glance. Just remember that LOW O<sub>2</sub> voltage results in HIGH milliamp signal being sent to the DPR. A HIGH milliamp reading is a response to a lean mixture. It is not a rich condition—it is a command to GO RICH.



# DRIVEABILITY CLINIC

## KE-Jetronic

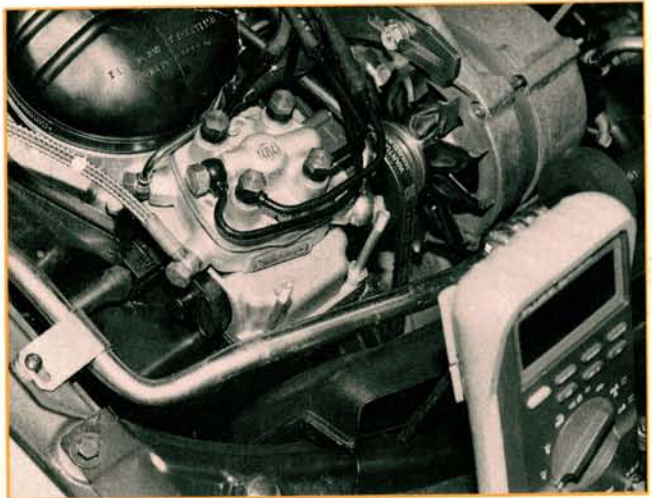
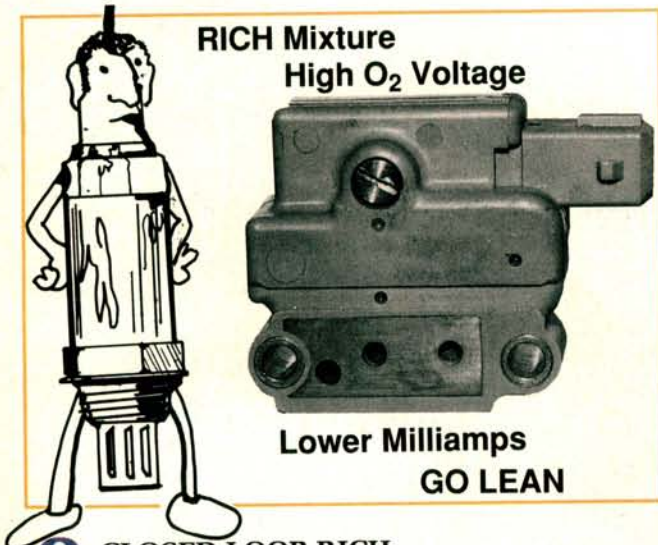

## 10 CLOSED LOOP IDLE

Milliamp readings will fluctuate within a specified range at idle. But be careful, normal ranges of operation are not all the same. For example, late '80s VW cars should fluctuate between 4 and 16 milliamps at warm, closed loop idle. Starting in 1990, however, Motronic versions of KE systems have a wider range, from 23 to -16 milliamps. Motronic is adaptive—it can custom tailor its normal range of operation to compensate for changes in altitude or even minor vacuum leaks (at least to a point). Make sure you have the specs for the car you're working on.

## 9 CLOSED LOOP RICH

Let's look at the opposite condition, namely a HIGH voltage signal from the O<sub>2</sub> sensor, indicating a mixture that's already too rich. The control unit will cut the amount of current to the DPR in response to this higher O<sub>2</sub> voltage. As a result, the DPR will partially open the valve leading to the lower chamber. This allows more fuel (upper chamber system pressure) to flood the lower chamber, leaning the mixture. Remember, a HIGH O<sub>2</sub> voltage results in a LOW milliamp signal being sent to the DPR. A LOW milliamp reading is not an indication of a lean mixture. It is a signal to GO LEAN.

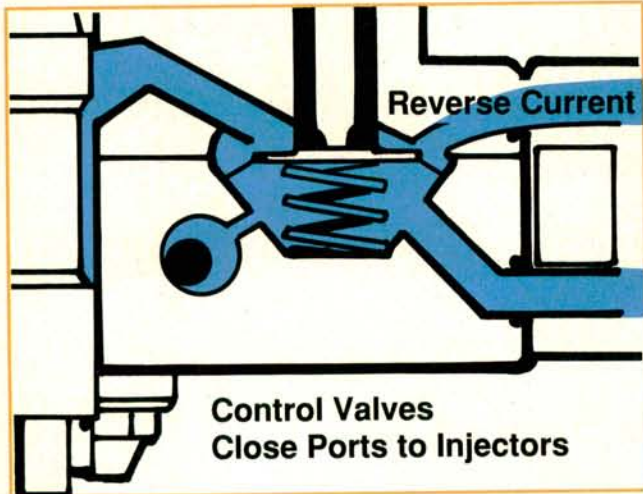

## 11 DECELERATION FUEL CUTOFF

A closed throttle, high manifold vacuum, and a lot of unburned fuel combine to make for a very dirty exhaust during closed throttle deceleration. KE keeps tabs on throttle position, and engine speed to know when closed throttle deceleration is occurring. Then it REVERSES current at the DPR (a negative milliamp reading). This completely opens the passage between upper and lower chambers until the pressures in the two chambers equalize. This explains why the pressure regulating springs are now in the lower chamber. With fuel pressures equal above and below the control valves, the mechanical force of the springs closes the valves, shutting off fuel to the injectors during decel.

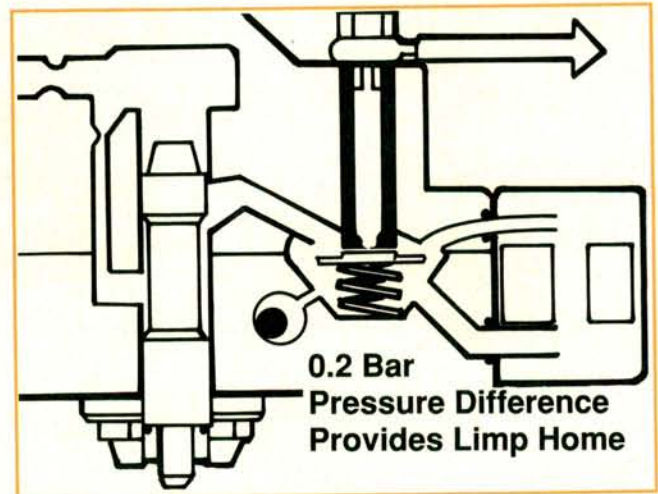

## 12 LIMP HOME MODE

What happens if the DPR fails? Will the car still run? Yes, but not well. And if it's shut off, it probably won't start again. Here's what happens: The valve in the DPR is like a flexible spring that gets pushed and pulled by two magnets in response to milliamp signals. If the DPR stops working for any reason, system pressure is strong enough to push some fuel past the spring. In spite of this small leak, the differential pressure is only 0.4 bar. This small differential loses another 0.2 bar to the mechanical force of the springs. The remaining 0.2 bar differential allows the car to limp home. Next month we'll take you through some basic tests and adjustments of this system.



# DRIVEABILITY CLINIC

## KEY COMPONENTS OF KE

