

Subaru 2.2 Liter Engine

Subaru 2.2 Liter Engine

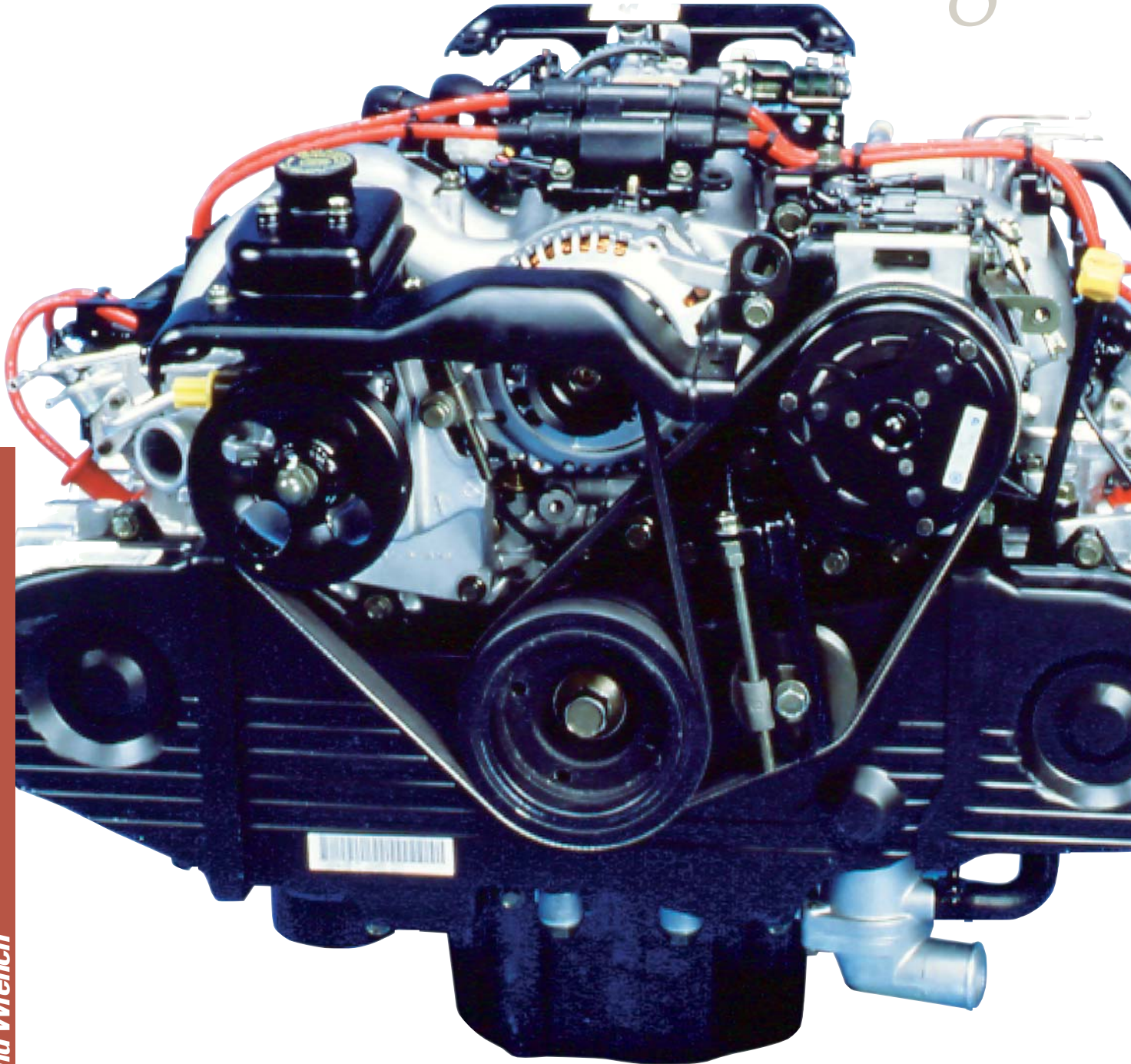

This edition of The End Wrench introduces the Subaru 2.2 liter naturally aspirated (N/A) and 2.2 liter turbocharged horizontally opposed overhead cam (OHC) engines. It reviews the mechanical features of these engines and the differences between existing engines. It also covers the procedures used in diagnosing and overhauling these engines. A list of applicable Important Notes and Cautions, Service Bulletins and Special Tools is included at the end of this article.

Introduction

Always refer to the appropriate model year Subaru Service Manual and the applicable service bulletins for all specification and detailed servicing procedures.

2.2L Engine Identification

The 2.2L engine designation is the sixth digit of the vehicle identification number (VIN). It is important to always first identify the engine before beginning diagnosis and servicing. Body type and transmission type, as well as the model year, are also information pertinent to engine diagnosis and servicing. This information is available from the VIN and the appropriate service manual.

The engine serial number is located on the machined boss on the left side of the clutch housing. The 2.2L engine designation is EJ22. Piston and bearing dimension information is stamped on a machined surface where the crankcase halves meet.

2.2L Engine Features

The 2.2L SOHC four valves per cylinder engine is an addition to the existing Subaru "Boxer" design. The horizontally opposed, four stroke, four cylinder, liquid cooled, gasoline engine has aluminum alloy block and heads. It uses a normally aspirated or turbocharged MPI system. The cylinder liners are of a cast iron dry type design.

Piston And Bearing Information



Cylinder Heads

The 2.2L engine uses a crossflow cylinder head design similar to the 1800cc OHC engine. Better breathing is provided by the two intake and two exhaust valves per cylinder which improves the intake and exhaust flow.

Fine-tuned high velocity intake and exhaust ports are used. The dual intake and exhaust ports are siamesed to further improve intake and exhaust flow.

The 2.2L engine uses a compact pentroof combustion chamber versus the bathtub design of the 1800cc/2700cc Subaru engines. It has a centrally located spark plug which provides the quickest, most efficient combustion with a uniform flame front from the plug to the top of the piston. This, combined with the 30 degree valve angle compliments the pentroof combustion chamber shape optimizing low and medium speed torque. The cylinder heads are interchangeable left to right.

The 2.2L turbocharged engine cylinder heads have been modified to withstand increased internal combustion pressures. The coolant passages have been changed to match the closed deck design of the crankcase. These heads are not interchangeable from side to side nor with the N/A engine cylinder heads. There are three holes in the right cylinder head for the turbo oil supply, oil return, and coolant return.

The intake valves and seats have been reduced to 27mm for the turbo engine only. The valve seat material for both the intake and the exhaust valves has been changed to increase hardness to provide a greater resistance to wear.

The valve train uses a single valve spring system versus the dual spring system of the 1800cc engine. The intake valves are larger than the exhaust valves. The valve seal color determines location: intake seals are black, exhaust seals are brown.

The camshaft bearing journals are located in the cylinder head. This design improves camshaft support. The left camshaft is longer than the right camshaft to properly align the cam belt sprockets due to cylinder head offset. A camshaft support bolts to the front of the left cylinder head to support the camshaft. A retaining plate, with oil seal, is attached to the rear of the left cylinder head. The rear of the right cylinder head has a cover plate which also serves as a thrust plate.

A camshaft support has been added to the right side of the turbocharged engine to supply oil to the turbo and return coolant from the turbo. Oil and water separation is provided by an o-ring. The camshaft has a different profile designed to match the operating characteristics of the turbo engine.

The rocker shaft assembly bolts to the cylinder head. There are eight bolts through the three cast iron supports. The intake valves have individual rocker arms, while a siamese rocker arm is used for each two exhaust valves. The all aluminum rocker arms have a sintered metal slipper as the cam contact. A pressed lead aluminum bushing is used for each rocker arm bearing surface. The position of the spring washers on the steel rocker shaft provide proper rocker alignment and spacing. These spring washers must be returned to their original position. The rocker shaft is part of the oiling system providing oil flow to the rocker bearing surfaces and HLAs. Relief valves at both ends of the rocker shafts maintain stable oil pressure to the HLAs.

Note: The roller rocker cam follower system that was introduced on the 1.8L Impreza engines, is installed on all 1995 model year and later 2.2 liter engines. The roller assemblies are not serviceable separately, but the rocker arms may be serviced as individual units.

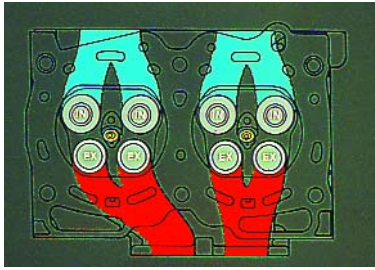

Cross Flow Cylinder Head

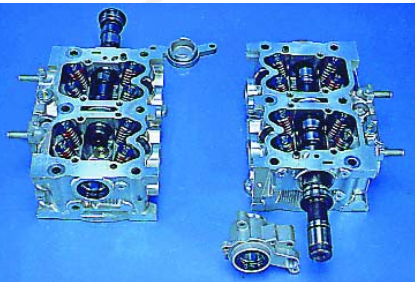

Camshafts

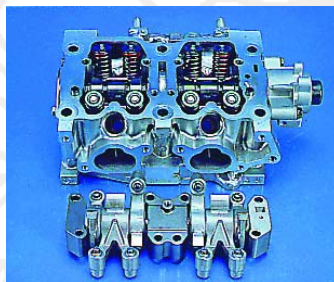

Rocker Shaft Assembly

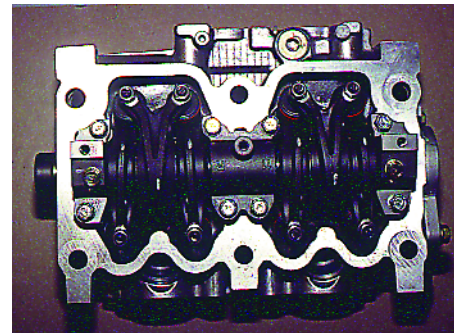

Roller Rocker Cam Followers

The HLAs used in the 2.2L engine are very small in size. Compare them to the size of the 1800cc and 2700cc HLAs. One advantage of these HLAs is the reduction of reciprocating weight. The HLAs are installed in the rocker arms while the 1800cc / 2700cc HLAs are installed in the cylinder head. The HLAs directly contact the valve stem instead of contacting the rocker arm as in the 1800cc/2700cc engines.

The head gaskets are carbon composition with a metal hooked core. O-rings are used to seal the oil passages. The entire gasket surface is silicone coated to improve sealing characteristics during initial installation. This also eliminates the need for re-torquing the cylinder head bolts after the engine has been operated. The N/A cylinder head gaskets are interchangeable from side to side.

The turbo engine cylinder head gaskets have been modified to match the closed deck design of the turbo crankcase. The gaskets are not interchangeable from side to side or with the gaskets from the N/A engine.

The water ports have been repositioned to match the passages in the heads and crankcase. The grommet area around the cylinder has been increased for improved sealing.

The gaskets can be identified by the number of notches:

- N/A: two notches
- TURBO: three notches

Crankcase

The crankcase has five main bearings which provide high case rigidity and improved crank support which increases engine life and performance. The crankcase uses an open deck casting design for the cylinder liners. The Turbo engine uses a closed deck design. In addition, the flywheel housing is cast with the crankcase which adds to increased rigidity and strength.

Oil jets have been added to the lower portion of the turbo crankcase in order to lubricate and cool the pistons. The jets are not operative at lower RPM because they are pressure controlled to open at 57 psi. The jets can be cleaned.

The balanced forged crankshaft has fillet rolled micro-polished journals for increased strength and reduced friction. Due to the "Boxer" design, a counterbalance shaft is not required.

Due to increased material used to strengthen the large end of the rod, the rod bolts are pressed into the rod. In comparison, the 1800cc rod bolts are pressed into the bearing cap. An oiling notch is located on the large end of the rod below the FUJI symbol. This provides oil flow to the piston pin and the cylinder walls. The rods are not drilled.

The 2.2L pistons are cast aluminum alloy and feature a 2mm offset piston pin. The pistons are directional for the left and the right side of the engine and are stamped with an "L" or "R". In addition, each piston is stamped with an arrow which must point to front of the engine. The valve reliefs for the intake and exhaust valves are different sizes to prevent valve contact with the piston should the cam belt break. The pistons use three rings, two compression and one oil.

The 1st and 2nd ring land groove thickness has been increased to provide additional strength due to the increased combustion pressures of the turbo engine. The piston ring's width and depth have also been increased to improve the cooling efficiency of the top of the piston. In addition, the top of the ring is coated with molybdenum to prevent metal disposition with the piston. The material itself has been changed to hard chrome for increased resistance to wear.



Hydraulic Lash Adjusters (HLAs)

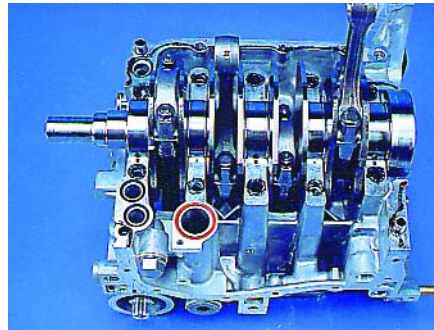

Crankshaft

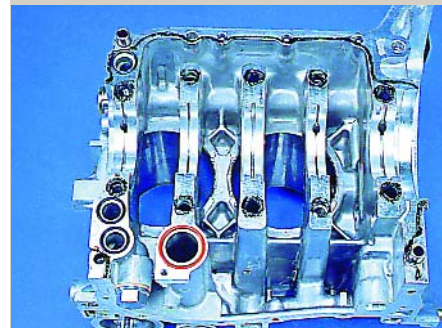

Crankcase

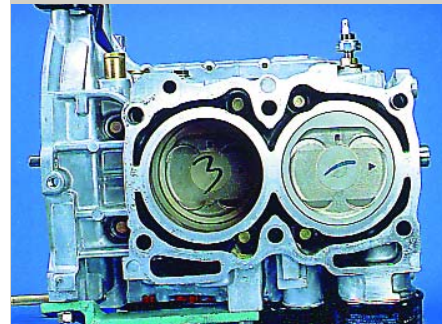

Pistons

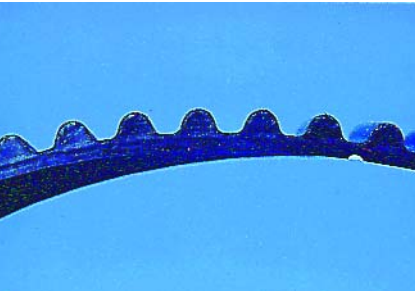

Timing Belt



Cam Belt Tensioner



Water Pump

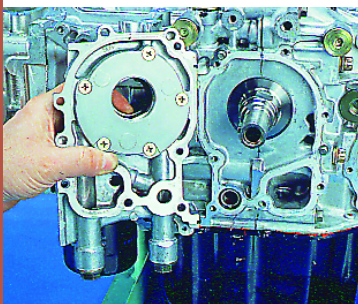

Oil Pump

Timing Belt System

A single belt is used to drive both camshafts and the water pump. This provides more precise valve timing. The cam belt width is 30mm (1.18 inches) to increase cam belt life. The belt is constructed of wear resistant double canvas and heat resistant rubber materials with a wire core. A round tooth profile is used for quieter operation. The belt has an automatic cam belt tensioner which allows for thermal expansion and contraction. The cam belt path is from the crankshaft sprocket to the tensioner, to the left camshaft sprocket, to the water pump pulley, to the lower left idler to the lower right idler, to the right camshaft sprocket, to the upper right idler and back to the crankshaft sprocket.

The cam belt covers and dust seals are resin molded and protect the timing belt from dust and water. There are additional dust seals on the left and right inner covers. These seals increase protection of the cam belt from dust and water and also improve cam belt noise isolation.

Cooling System

The water pump pulley is driven by the back side of the timing belt. The pump is mounted to the lower front of the engine. The thermostat is located in the lower part of the pump housing. This location provides even engine warm-up by improved metering of the coolant temperature. The thermostat senses the temperature of the crankcase and radiator coolant as it is mixed.

Because the thermostat housing is located on the lower front of the engine, all of the coolant must be drained to change the thermostat.

The heater core also serves as the by-pass system.

Oil Pump

The trichoid gear type oil pump is driven directly by the crankshaft. The pump is bolted to the front of the engine for serviceability. The relief valve located in the pump regulates oil pressure to 71 psi (5 kg-cm²). The filter by-pass valve is located in the oil filter.

The oil pump has a reservoir which maintains oil for rotor lubrication. This is especially helpful when the engine has not been operated for extended periods of time. The reservoir also provides emergency oiling for the pump if there is a temporary loss of oil supply.

2.2L Engine Servicing & Diagnostics

In Vehicle Servicing

The following services may be completed without removal of the engine from the vehicle.

- Removal/replacement of cam belt
- Water pump removal/replacement
- Oil pump servicing
- Intake manifold
- Rocker covers
- Rocker arm assemblies
- Cylinder head removal
- Camshafts
- Turbocharger

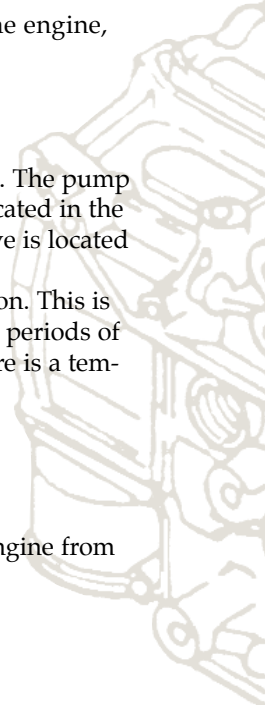

Engine Diagnostics

Note: The following diagnostics pertain to the 2.2L engine only.

- Valve train noise (clacking sound). Operate the engine for approximately one hour before diagnosing HLAs as the problem. Do not rev the engine!
- If the rocker shaft relief valves are plugged, the rocker shaft oil pressure will increase during low engine temperature operation. This could result in the HLAs being forced part way out of the rocker arm sockets. A clacking sound may be produced which is similar to collapsed HLAs. Engine misfire may also occur during this condition.

If the relief valves will not hold pressure, the HLAs may collapse, again producing a clacking sound.

2.2L Engine Disassembly

Note: Refer to the service manual for the detailed step-by-step disassembly sequence. The following information addresses special steps only.

The 1800cc engine stands 499817000 can be used with adapter RH 498457000 and adapter LH 498457100 to support the 2.2L engine. Remove the engine accessories: i.e. drive belts, alternator, air conditioning compressor, and brackets.

Timing Belt Removal

Use crankshaft pulley wrench 499977000 to remove the crankshaft pulley bolt, then remove the pulley.

Use the crankshaft pulley to rotate the crankshaft to align the belt timing marks.

Note: There are two timing marks on both the cam pulleys and the crankshaft pulley, a notch and an arrow. Align the notch on the outer rim of each camshaft pulley with the notch on the inner cam cases. Align the notch on the rear flange of the crankshaft sprocket with the notch on the oil pump housing.

Mark the belt at the three timing notches. This will make reinstallation much easier and also insures proper placement of the belt between the left and right cam pulleys.

Mark the belt rotation direction. The belt must be reinstalled to rotate in the same direction.

Note: New belts will have the timing marks printed on the belt as well as arrows indicating direction of rotation.

First, loosen the cam belt tensioner mounting bolts.

Note: Do not remove the bolts.

Remove the idler pulleys in this sequence: lower right (1-3 side), then the lower left (2-4 side, next to the water pump). Then remove the cam belt.

Finally, remove the cam belt tensioner pulley, tensioner assembly, and crankshaft sprocket.

Remove the left and right camshaft sprockets using cam wrench 499207100 or 49940700.

Notice the locating pin on back of the sprockets for reinstallation. Also locate the reluctors on the back of the left camshaft sprocket. These are the cam angle sensor reference triggers.

Note: The left camshaft sprocket must not be installed on the right camshaft, as damage to the inner right cam belt cover may occur. A no start condition also will result.

Remove the mounting bolts and carefully remove the tensioner bracket to avoid damage to the friction-fit dust seals.

Remove the left and right inner cam belt covers. Note the location of the friction-fit dust seals.

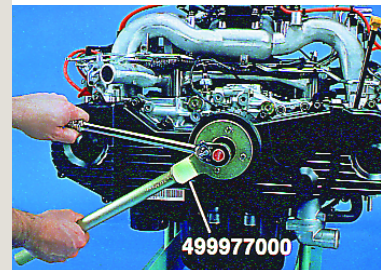

Removing Crank Pulley

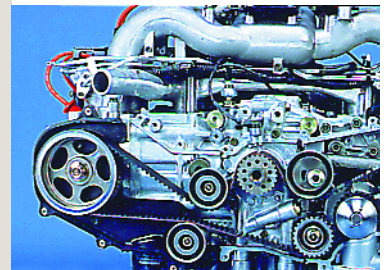

Marking Timing Belt

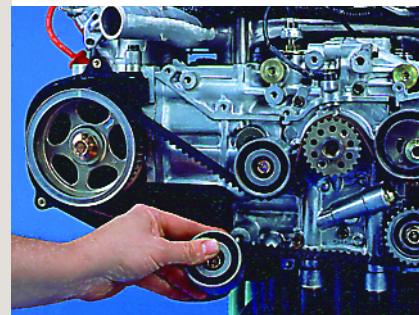

Removing Idler Pulleys

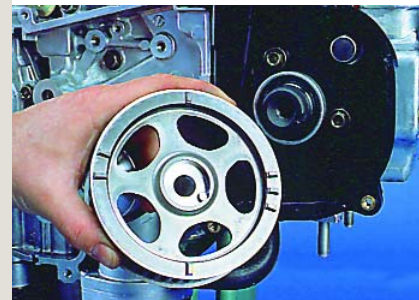

Camshaft Sprocket



Inner Cam Belt Covers

Engine Accessory Removal

Remove the hoses, electrical connections, sensors, switches, intake manifold, and intake manifold gaskets.

Note: The rubber coated metal gaskets are one-time use only.

Remove dipstick tube and then remove the water pump and rubber coated metal gasket. The gasket is one-time use only. Retain the dust seals for later reassembly.

Remove the oil pump. Observe the condition and location of the o-ring seal and the dust seals. Retain the dust seals for later reassembly.

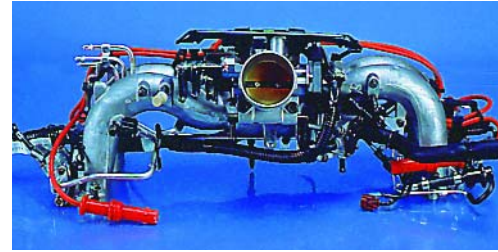

Intake Manifold

Cylinder Head Removal

Loosen all head bolts in the reverse order of the tightening sequence, and then remove all of the cylinder head bolts except #1. Lightly tap the cylinder head with a rubber mallet to loosen the head from the gasket. Then remove #1 bolt and the cylinder head with the head gasket. Repeat the above steps for the other cylinder head.

Note: The head gaskets are carbon composition with integrated o-rings. The gaskets are interchangeable from left to right on N/A engines only.

Note: It is not necessary to remove the valve cover while removing the cylinder head unless servicing of the valve components is required.

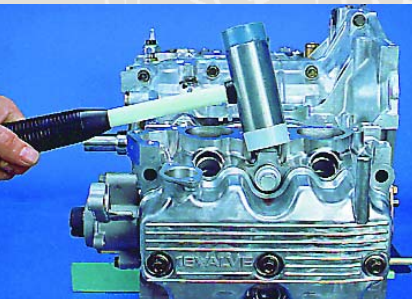

Removing Cylinder Head

Oil Pan Removal

Remove the oil pan bolts. Use a thin gasket scraper/putty knife and a rubber mallet to loosen the oil pan. Remove the oil pan. Notice the location of the oil seal for the drain tube. Remove the oil pick-up tube and also note the o-ring. Remove the oil pan baffle plate (windage tray).



Removing Oil Pan

Piston Pin Removal

Use piston pin remover 499097300 or 499097500 to remove the piston pin. Insert the tool 3/4 of the way into the pin and pull the tool with the pin through the access hole. Repeat for the remaining pistons. Finally, rotate the crankshaft to position the pistons at the top of the cylinders. Repeat the procedure for the other cylinders.

Note: Use caution while rotating the crankshaft to prevent the connecting rod large ends from damaging the lower cylinder bores.

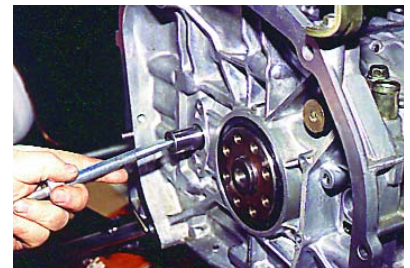

Removing Wrist Pin

Hidden Crankcase Bolts

To split the crankcase remove all 16 of the crankcase bolts. Six of the bolts are hidden in the water passages, four in the RH case (1-3 side) and two in the LH case (2-4 side).

Note: All six of the hidden shouldered crankcase bolts have sealing washers. These bolts are not interchangeable with the other crankcase bolts. The sealing washers are one-time use ONLY.

Carefully separate the crankcase halves.

Note: Identify the location of the four O-rings (three small, one large), in the mating surface of the right (1-3 side) crankcase. The black o-rings are for oil passages, the orange o-ring is for a coolant passage.



Hidden Crankcase Bolts And Sealing Washers

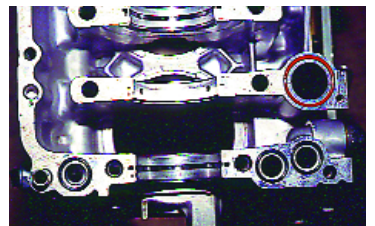

Crankcase O-Ring Seals

2.2L Component Inspection and Servicing

Cylinder Head Disassembly

Remove the valve rocker cover bolts and the valve rocker cover. Then remove the eight rocker shaft assembly retaining bolts and the rocker shaft assembly.

Note: Remove the rocker assembly slowly to prevent binding against the mounting dowels.

HLA Handling

Use a small screwdriver to remove the HLA from the rocker socket. Do not damage the o-rings of the machined surfaces when removing the HLAs. To check the HLAs for proper operation, squeeze the HLA between your thumb and finger. The HLA should not compress, it should not be spongy.

Place an HLA in a clean 12 mm socket. The socket serves as an oil reservoir. Add engine oil to the socket. Use a small allen wrench or paper clip to depress the check ball. Depress and release the HLA plunger while you hold the check ball open. This purges the air from the HLA and fills the HLA with oil. It usually requires only one stroke to fill the HLA. Store the HLAs in engine oil for later reassembly.

Note: Partially filled HLAs will result in noisy operation of the valve train for approximately one hour. To test, squeeze the HLA between your thumb and finger. If the HLA is spongy, repeat the fill process. If the HLA can not be pumped to a firm condition, replace it.

Assemble the rocker shaft components, rocker arms, spring washers, and the rocker shaft supports. Lubricate shaft and rocker arms with oil.

Note: The rockers and supports should be returned to their original position on the shaft. The cut out portion of the rocker shaft must face the oil hole in the rocker support. The spring washers must be properly located on the shaft. Always replace any deformed spring washers.

Lock the rocker shaft in the proper position with the two retaining bolts. Then fill the HLA sockets with engine oil.

Press the HLAs (by hand) into the rockers to install the HLAs in the rocker arms. Some oil will drain from the bleed hole. Press the HLA until the o-ring seats. Install the remaining HLAs. Be sure to check for spongy HLAs during installation.

Note: The HLA O-rings should always be replaced when the HLAs are reinstalled.

Look for leakage from the tensioner rod and seal area. Slight traces of oil at rod oil seal does not indicate a problem.

Note: Refer to Service Manual Section 2-3 (W2B2) "Inspection of belt tension adjuster" for tensioner compression specifications.

Rocker Arm Inspection

Inspect the rocker arms for damage. Also inspect the rocker arm bearing surface for wear. Replace the rocker arm if bearing wear is excessive.

Note: Refer to Service Manual Section 2-3 (W3C2), Inspection of Valve Rocker Arm for specifications.

Finally, inspect the rocker arm cam contact surface. Replace the rocker arm(s) when they are scored or gouged.



Removing HLA



Filling And Bleeding HLA

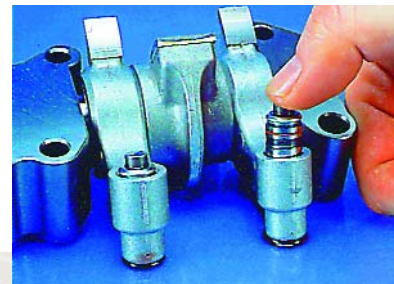

Installing HLA

Valvetrain Components

Use valve spring remover 499718000 to remove the valve springs. Then remove the valves and seals. The intake seals are black and the exhaust seals are brown.

Use valve seal installer 498857100, to install the valve guide seals (black for intake, brown for exhaust). Then use cylinder head table 498267200 and valve spring remover 499718000 to install the valve spring and retainer. Install the camshaft into the cylinder head bearing journals. Be careful to not damage or score the camshaft journals.

Install the left rear camshaft plug (oil seal). Then install the oil seal using oil seal installer 499587100.

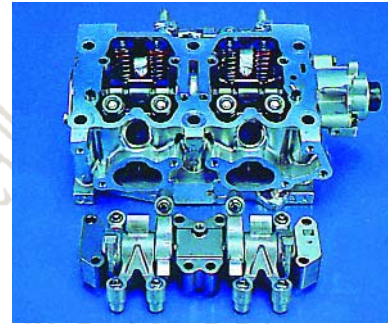

Inspecting Rocker Arms

Storing Cylinder Heads

Install the rocker cover to the cylinder head. Temporarily store the cylinder head by standing it on the exhaust manifold studs. This prevents bleed down of the HLAs. Repeat these steps for the other cylinder head.

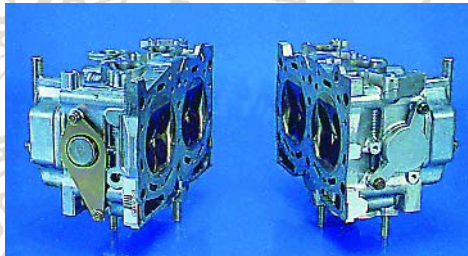

Cylinder Head Storage Position

2.2L Engine Reassembly

Always refer to Service Manual Section 2-3 (W6C5 to W6D2) for the bearing size, oil clearance, and torque specifications. The "FUJI" symbol on the connecting rods must face the front of the engine.

Apply sealant to the crankcase mating surface on the o-ring side of the crankcase. Do not allow the sealant to enter the o-ring grooves, oil passages, or bearing grooves. Install the crankshaft assembly. Align the connecting rods, and assemble the crankcase halves.

Caution: Remove all fluids from the threaded portions of the case halves. This prevents hydrostatic lock and potential cracking of the crankcase.

Install the four hidden crankcase bolts on the 1 - 3 side. Always install new seal washers to these bolts. Install the two remaining 1 - 3 side crankcase bolts. Torque the 6 large bolts on the right side (1 - 3) to 4 to 22 ft lbs (2 to 3 Kg-m). Next install the two hidden crankcase bolts on the 2- 4 side. Always install new seal washers. Install all of the remaining crankcase bolts. Torque all the crankcase bolts to specifications. Start with the right side (1 - 3) bolts.

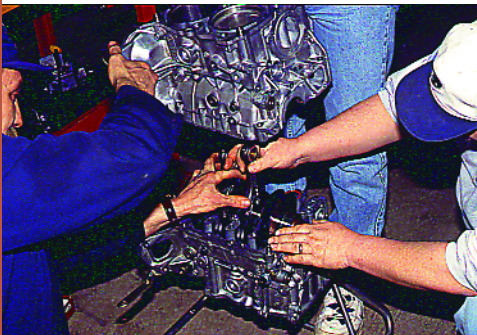

Assembling Crankcase

Piston Installation

The pistons are directional and must be returned to the original cylinder locations. Use piston guide 498747100 to install the pistons. The pistons are marked with an "L" for the left side and an "R" for the right side. The arrow on the head of each piston must point to the front of the engine.

Rotate the crankshaft to position the connecting rod with the piston. Use piston pin guide 499017100 to align the piston and connecting rod. Then install the piston pin. Install the circlip. Note the proper direction of the circlip on early production models. The tang must be tilted out. Repeat for the remaining pistons. Slowly rotate the crankshaft two revolutions. This confirms the proper installation of the pins. Install the front piston pin access plugs. Use new aluminum sealing rings and sealer.

Install the left side access cover and new o-ring, PCV baffle plate, and piston pin plug using a new sealing ring and sealer.

Install the oil pan baffle plate and oil pick-up tube. Be sure to install a new o-ring to the oil pick-up tube.

Install a new oil seal on the oil return tube. Apply liquid gasket sealer FUJI Bond 1207C or equivalent to the oil pan mating surface. Install the oil pan and oil pan retaining bolts. Diagonally torque the oil pan bolts on one pass to 0.5 Kg-m (3.6 ft lbs).

Install the dipstick tube. Be sure to use two (2) new o-ring seals.

Install the rear main oil seal using seal installer (499587200), oil seal guide (499597100) and a plastic hammer. Lubricate the seal with engine oil prior to installation.

Install the oil pump. Refer to service manual section 2-4(W1D0) for proper location of the sealer and o-ring. Apply FUJI Bond 1215 sealer or equivalent to the mating surface of the oil pump. Align the flats two on the oil pump with the two flats on the crankshaft and the mounting holes in the oil pump flange with the two dowel pins. Install the mounting bolts and torque to specifications.

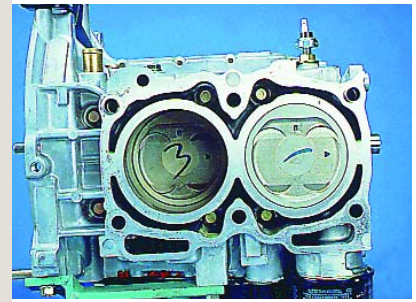

Installing Pistons

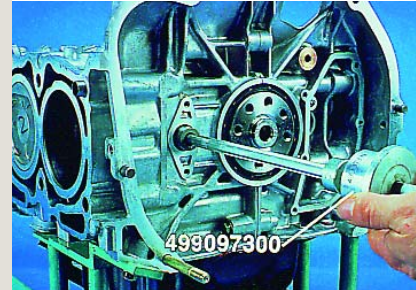

Piston Pin Guide

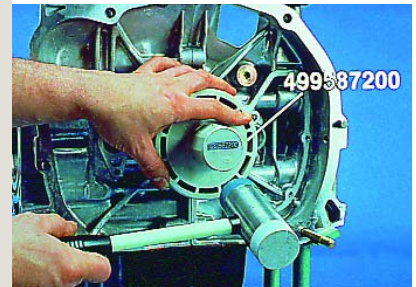

Installing Rear Main Seal

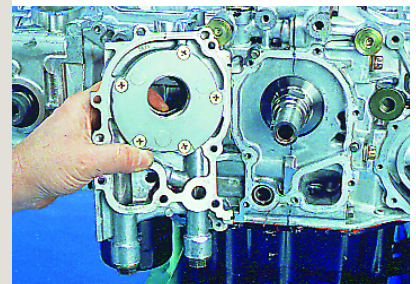

Installing Oil Pump

Cylinder Head Torque Sequence

Install a new cylinder head gasket (dry) and the cylinder head. Follow the bolt torque sequence and procedures listed in the appropriate MY Legacy Service Manual, Section 2-3 (W5E1).

Compressing the Tensioner

Slowly compress the cam belt tensioner in a vise, using aluminum or brass jaws, until the hole in the piston aligns with the hole in the tensioner case. Install a tensioner plunger retaining pin. You may use a small allen wrench as a retaining pin. Install tensioner assembly to the crankcase, do not tighten the mounting bolts.

Note: Do not remove plunger retaining pin until cam belt is completely installed.

A revised cam belt tensioner design was introduced on later 2.2 liter engines. The revised tensioner requires a special service procedure to retract the tension piston. Compressing the piston in a vise will damage the tensioner piston and it will not extend properly when it is reinstalled on the engine. Refer to the appropriate section in the Subaru service manual for tensioner handling procedures.

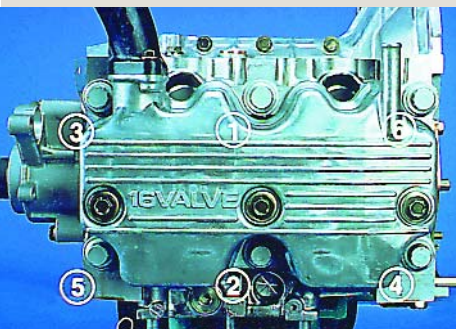

Torquing Cylinder Head Bolts



Compressing Belt Tensioner Piston



Revised Belt Tensioner Procedure

Cam Belt Installation

Install the camshaft sprockets using camshaft sprocket wrench 499207100 or 499407000. Refer to the service manual for the proper specifications. The left sprocket has the cam angle reluctors and is not interchangeable with the right sprocket. Damage to the dust cover will result from improper installation.

Install the cam belt idler pulleys except the lower right (1 - 3 side) and the lower left (2 - 4). Install the crankshaft sprocket and align the crankshaft sprocket and camshaft sprockets with the belt timing notches (12 o'clock). Do not rotate camshafts more than necessary as the HLAs will bleed down.

Install the cam belt in the following sequence:

- ① Begin at the crankshaft sprocket
 - Align the mark on the cam belt with the crankshaft sprocket notch.
- ② Place the belt under the cam belt tensioner and over the left cam sprocket.
 - Align the mark on cam belt with the camshaft sprocket notch.
- ③ Place the belt under the upper right idler pulley and over the right cam sprocket.
 - Align the mark on the cam belt with camshaft sprocket notch.
- ④ Place the belt over the water pump pulley.
- ⑤ Install the lower left and right idler pulleys.

Use a screwdriver to load the tensioner idler. Push the idler toward the crankshaft sprocket. Tighten the tensioner mounting bolts to specified torque.

Carefully remove the tensioner plunger retaining pin. This automatically sets the cam belt tension. Slowly rock the crankshaft left to right to left to distribute the cam belt tension to the belt.

Note: Do not rotate the crankshaft unnecessarily as the HLAs may bleed down.

Verify that the cam timing is correct by checking the cam belt alignment. The crankshaft sprocket notch and mark should be aligned. Check to be sure that the notches of the camshafts sprockets and the belt marks are properly aligned.

Install the outer cam belt covers. Be sure to install the shouldered bolts in the center cover. Check the position and fit of the dust seals.

Install the pulley using crank pulley wrench 499977000. Install the engine accessories and drive belts. Note the new style belt tension adjusters. Fill the engine with oil.

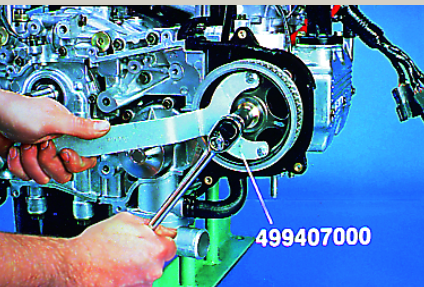

Reinstalling Camshaft Sprockets

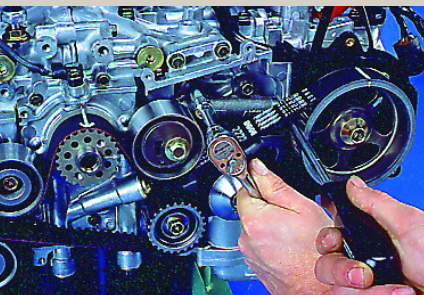

Loading Tensioner Idler

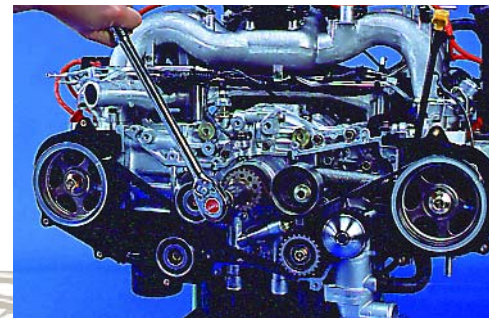

Checking Cam Belt Alignment

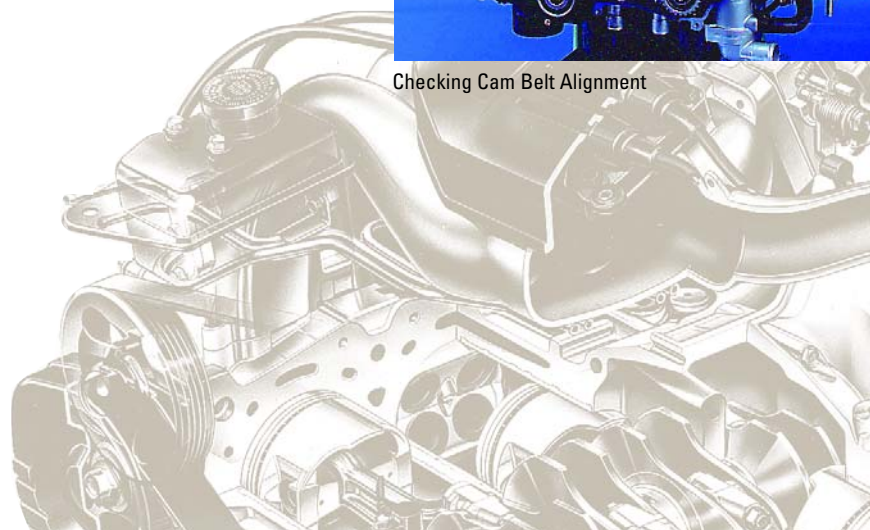

2.2 Liter Engine Enhancements

Beginning in the 1997 Model Year, the 2.2 liter engine for 1997 Legacy and Impreza models has had internal and external changes that yield an approximately 10% increase in power and 3% increase in fuel economy. Accomplishing this involves many factors, one of which is engine friction reduction.

The piston, a major source of engine friction, has been coated with a friction reducing agent called Molybdenum. This thin coating not only allows smoother travel through the cylinder, but also reduces cylinder wall scuffing.

The skirt of the piston has been reshaped and the overall weight has been reduced by approximately 100 grams. Compression ratio has been increased to 9.7 to 1 by reshaping the crown of the piston. This eliminates the clearance that was available between the piston at TDC and the fully opened valve. Piston pin offset has been changed to 0.5 mm. Piston to cylinder wall clearance has been reduced by increasing the piston diameter.

Another source of high engine friction is the valve train. Hydraulic lash adjusters (HLAs) are always in contact with the valves. The hydraulic pressure of the lash adjuster must be overcome during operation and during the most critical time of engine start. To overcome this situation and to contribute to the total reduction of friction loss, 1997 and later SOHC engines have solid valve adjusters. The scheduled service of this valve train is set at 100,000 miles. SOHC engines now use an adjustment screw to adjust valve clearance.

Tools required for 2.2 valve adjustment include a thickness gauge, 10mm wrench, stubby standard screwdriver, and crankshaft wrench.

Follow the instructions below for set up and adjustment.

- Remove the right bank camshaft belt outer cover.
- Rotate the engine until the arrow on the camshaft sprocket is at 12 o'clock. Remember that the camshaft sprocket has an arrow and a mark for the timing belt timing. Make certain that the arrow is used for valve adjustments, not the mark.

Standard valve clearance:

Intake valves 0.20 ± 0.02 mm

Exhaust valves 0.25 ± 0.02 mm

- Using a standard thickness gauge to measure the clearance of the intake and exhaust valves in cylinder 1 only. Adjust the clearance by loosening the locknut and turning the adjustment screw until the proper clearance is obtained.
- Rotate the engine until the arrow on the camshaft sprocket is at 3 o'clock. Check and adjust the clearance of the intake and exhaust valves on cylinder 3 only.
- Rotate the engine until the arrow on the camshaft sprocket is at 6 o'clock. Check and adjust the clearance of the intake and exhaust valves on cylinder 2 only.
- Rotate the engine until the arrow on camshaft sprocket is at 9 o'clock. Check and adjust the clearance of the intake and exhaust valves on cylinder 4 only.

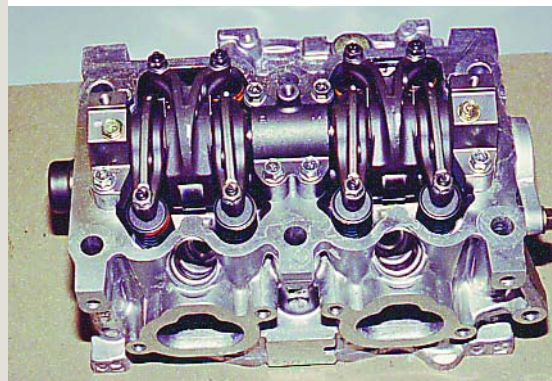
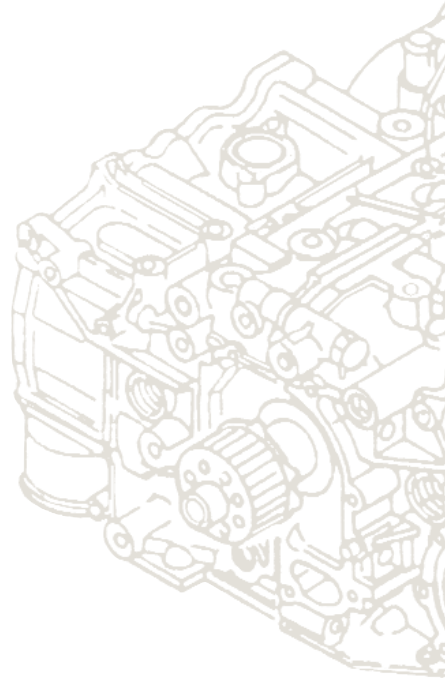

Solid Valve Adjusters

Notes and Cautions

2.2L Engine Disassembly

- There are two timing marks on both the cam pulleys and the crankshaft pulley, a notch and an arrow. Align the notch on the outer rim of each camshaft pulley with the notch on the inner cam cases. Align the notch on the rear flange of the crankshaft sprocket with the notch on the oil pump housing.
- New belts will have the timing marks printed on the belt as well as arrows indicating rotation direction.
- During the cam belt removal procedure, initially loosen, but do not remove, the cam belt tensioner bolts until the belt and idler pulleys have been removed.
- The 1800cc cam wrench must be modified to fit the 2.2L camshaft sprocket. Tool 499207100 is the preferred tool.
- The rubber coated metal intake manifold gaskets are one-time use only. Discard and replace with a new set.
- The carbon composition head gaskets with integrated o-rings are interchangeable from left to right on 1990 to 1994 N/A engines only.
- It is not necessary to remove the valve cover while removing the cylinder head unless servicing of the valve components is required.
- Use caution while rotating the crankshaft to prevent the connecting rod large ends from damaging the lower cylinder bores.
- All six (6) of the hidden shouldered crankcase bolts have sealing washers. These bolts are not interchangeable with the other crankcase bolts. The sealing washers are one-time use ONLY.
- Identify the location of the four o-rings (three small, one large), in the mating surface of the right (1-3) side crankcase. The black o-rings are for oil passages, the orange o-ring is for coolant passage.
- Remove the rocker assembly slowly to prevent binding against the mounting dowels.

Partially filled HLAs will result in noisy operation of the valve train for approximately one hour. To test, squeeze the HLA between your thumb and finger. If the HLA is spongy, repeat the fill process. If the HLA can not be pumped to a firm condition, replace it.

2.2L Engine Reassembly

- The rockers and supports should be returned to their original positions on the shaft. The cut out portion of the rocker shaft must face the oil hole in the rocker support. The spring washers must be properly located on the shaft. Always replace any deformed spring washers.
- The HLA o-rings should always be replaced when the HLAs are reinstalled.
- Install the rocker assembly carefully to prevent binding against the mounting dowels.
- Remove all fluids from the threaded portions of the case halves. This prevents hydrostatic lock and potential cracking of the crankcase.
- Carefully follow the cylinder head torque sequence. Remember that the re-tightening angle must not exceed 180 degrees. Proper use of the torque procedure eliminates the need to retorque the cylinder head bolts after running the engine. Refer to Service Manual Section 2-3 (W5E1).
- The left camshaft sprocket must not be installed on the right camshaft, as damage to the inner right cam belt cover will result.
- Do not remove the plunger retaining pin from the cam belt tensioner until the cam belt is completely installed.
- Do not rotate the crankshaft unnecessarily as the HLAs may bleed down.

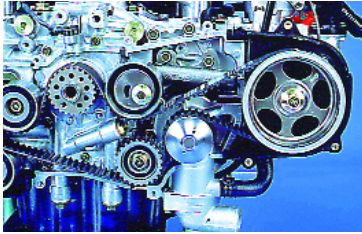

Tensioner Bolt Caution

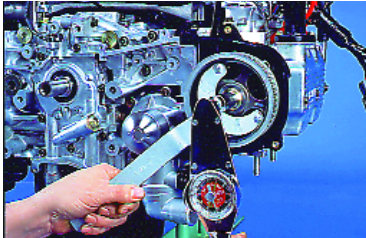

Tightening Camshaft Sprocket Bolts



Crankcase Bolt Holes

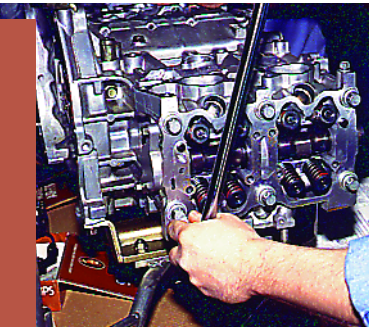

Cylinder Head Torque Sequence



Cam Belt Tensioner Retaining Pin

Service Bulletins

No.	Date	Title	Remarks
01-106-88	2/1/88	Recommended Sealants and Adhesives	
02-44-86	2/4/86	OHC Replacement Valve Guide Seals	
02-48-86	7/2/86	Valve Guide Seals	Instructions for servicing valve guide seals with the engine in the vehicle and using tool kit part number X9971AA100
02-49-86	10/9/86	Valve Stem Height Measurement	
02-50-86	11/7/86	Turbocharger Diagnosis	
02-56-87	10/26/87	Turbo Engine Knocking Noise	
02-64-88	6/14/88	All Subaru Engines- Intake Manifold Gasket Information	
02-67-88	12/22/88	Proper Procedure For LH Timing Belt Tension - 1.8L	
02-68-89	5/17/89	Legacy HLA Noise Rocker Shaft Cleaning Procedure	
02-69-89	7/11/89	Legacy Engine Oil Level Checking	
02-71-89	10/18/89	Maintenance Reminder	
02-74-90	4/9/90	Engine Oil Pan Removal	
02-75-90	9/11/90	Bleeding Air From Legacy Cooling System	
02-76-91	4/2/91	Radiator Replacement Procedures	
02-77-90	12/28/90	Legacy Cylinder Head R&R In-Vehicle Procedure	
02-78-91	1/24/91	Cam Belt Timing Tips	
02-79-91	3/29/91	Legacy Engine Block Mod A/C Compressor Mounting Bolt Change	
02-80-91	5/9/91	Legacy Engine Oil Level Gauge	
02-81-91	8/15/91	2.2L Cylinder Head Resurfacing (Grinding) Specs 1991 Legacy Service Manual Correction	
02-83-91	9/17/91	Engine Oil Seepage at Cylinder Head or Acc. Mounting Bolt	
02-84-91	11/12/91	Diagnostic Aids for Driveability Complaints	
02-85-91	12/19/91	Revised Cylinder Head Bolt Torque Procedures	
02-88-93	2/5/93	Cylinder Head Crack Between Valve Seats	
02-90-94	12/2/94	Engine Oil Pump Leaks	
02-90-94R	12/2/94	Engine Oil Pump Leaks	
10-48-87	11/30/87	Cooling System Cleansing	

General Hand Tools & Supplies

General hand tools and supplies
 Dial indicator
 Dye penetrant
 Feeler gauge
 Micrometers
 Plastigauge
 Press
 Rubber or Plastic Hammer
 Fuji Bond 1105 or equivalent
 Fuji Bond 1107C or equivalent
 Fuji Bond 1215 or equivalent
 Torque wrench (ft-lb) and (in. lb.)
 Vernier calipers
 Reference Materials
 Subaru Service Manuals
 Technician Reference Booklets

Special tools

399094310 Piston pin remover (1800cc tool)
 479587300 Oil seal installer
 498037100 Camshaft journal plug installer
 498267200 Cylinder head table
 498457000 Engine stand adapter RH
 498457100 Engine stand adapter LH
 498747100 Piston guide
 498857100 Valve oil seal guide
 499017100 Piston pin guide
 499037100 Connecting rod bushing remover & installer
 499097500 Piston pin remover
 499207100 Camshaft sprocket wrench
 499587100 Camshaft oil seal installer
 499587200 Crankshaft oil seal installer
 499597000 Camshaft oil seal guide
 499718000 Valve spring remover
 499718400 Valve spring compressor adapter
 499767000 Valve guide adjuster
 499767200 Valve guide remover
 499767400 Valve guide reamer
 499817000 Engine stands (2)
 499977000 Crank pulley wrench
 898968600 Circlip pliers (or SNAP-ON long nose pliers 911CP)
 499597100 Crankshaft oil seal guide
 499987500 Crankshaft socket

Note: Yearly Subaru Service Bulletin Publications are available for purchase by calling Helm Incorporated at 1-800-782-4356. You may also FAX your request to 1-313-865-5927, between the hours of 8:00am - 6:00pm EST, Monday through Friday. Helm accepts Mastercard, Visa, Discover, checks, and money orders. Overnight or Second Day shipping is available at additional cost.