

2000-2001 Import

Tech Report

There's a horsepower race among the new imports, and a clean air race too. These used to be mutually exclusive attributes, and although electronics play a large part in what's happening, there's a lot of mechanical progress happening, too. To top it off, aggressive styling also has been added to many of the new models to help draw the customer's attention.

Every auto manufacturer is making or planning to make limited-production eco-cars, like the hybrid gasoline-electric Toyota Prius or the Honda Insight. These may be service challenges some time in the future, but you're more likely to have to work on more conventional designs, such as the Nissan Sentra CA (Clean Air), which already meets SULEV (super ultra low emissions vehicle), the highest standards California currently has on the books. Consequently, this report will focus on what's being (or will be) produced in volume.

As the auto manufacturers fight for attention in the marketplace, model-year designations have lost much of their original significance. New models are now introduced year-round, rather than crammed into the traditional Fall new model introduction period. Legally, anything that came to market on January 1st or later can be labeled a "2001." Some manufacturers chose to ignore this loophole and continue new models until Fall under the 2000 MY designation. Others have already introduced their 2001 models (or will very soon).

These conflicting model year designation policies can lead to confusion at the independent repair level. Some of these newer vehicles will end up in independent garages long before the three-year warranty period is up, for one reason or another (customer-pay work, including accidents). Is it a 2000 or a 2001? When you need to order parts, don't try to identify a vehicle's age by looking at the body or by questioning the customer. Check the VIN.

Nissan

Frontier and Xterra

The 'industrial-strength' 2001 Nissan Frontier pickup goes on sale early this summer. Although the 2.4 liter four and 3.3 liter V-6 are largely carry-overs, the 3.3 liter V-6 will be supercharged this Fall, raising its horsepower from 170 to 210 (and torque from 200 to 240 lbs. ft). The Xterra, a compact sport-utility on the Frontier platform, has been wildly successful, as its 3.3 V-6 is something the four-cylinder Honda CR-V and Toyota RAV4 can't match. The Xterra's body mounts are softer than the Frontier's, taking much of the harsh edge off its pickup-truck ride.

Pathfinder

The 2001 Pathfinder gets a whopping power increase, from the 170 in that 3.3 V-6 to 250 in a new 3.5 liter V-6. Can 0.22 liter (about 13 cubic inches) really make that much difference? No, the truth is, it's a new engine based on the Maxima 3.0 V-6 architecture (see Figure 1).

The 3.3 is a cast-iron, regular-gas engine, with two valves per cylinder. The 3.5 V-6 has an aluminum block, four valves per cylinder, runs on premium and at 8.8 is over two seconds faster from 0-60. Both engines get the same fuel mileage (15-17 city and 18-19 highway, depending on drivetrain). The 3.5 V-6 has a computer-controlled, dual-path intake manifold, like the Maxima V-6. And the overall size of the induction system really fills the engine compartment, including the previous open space at the cowl. The engine also has variable valve timing, calibrated to improve low-end torque (nine percent more torque at 2000 rpm).

Maxima, Infiniti I30

Both were completely restyled, and the 3.0 V-6 was reworked to increase horsepower from 190 to 222. The camshafts as well as intake and exhaust plumbing were redesigned, including a two-stage intake manifold and free-flow muffler with a dual-path (separated by a spring-loaded flapper). Hardly sounds like enough to get that much more power, but there's long been a suspicion that 190 was a lowball number. The appearance of the rear suspension may puzzle you. Yes, the lateral link was moved from the front to the rear of the twist axle. Reason: in that location, the rear self-steering changes from toe-in to neutral under high lateral forces, improving stability when cornering (Figure 2).



Nissan Frontier for 2001 gets a 'military-industrial' look, with exposed bolts and rectangular shapes. Shown is the Crew Cab, which has full-size rear doors and a shortened bed.

Sentra

There's definitely a move to turn econoboxes into more appealing vehicles. The Ford Focus and Toyota Echo do it with funky styling and a lot of new engineering. Sentra does it with an 'expensive look' and more performance. The 115-horse, 1.6 liter base four-cylinder engine is gone, replaced by a new 1.8 liter, 126-horse four — basically a bored-out powerplant updated in other areas also. This new engine has four oxygen sensors, two on each side of the catalyst, plus a direct ignition system (picked up from the Maxima), variable valve timing and a computer-controlled swirl valve in the intake ports (to improve air/fuel mixing during warm-up, for lower emissions).

The 1.8 meets California LEV (low-emission vehicle specs), but it's the 50-states vehicle in our illustrations.



Figure 1: Pathfinder with 3.5 V-6, the big induction system (including dual path intake manifold) fills up a lot more space and extends to rear, closing up some of the access at the cowl.

Figure 2. Modified Maxima/Infiniti I30 rear suspension. It's still a twist beam, but the lateral beam has been moved to the rear side of the twist-beam, which improves the stability, as the tires turn from toe-in to neutral under lateral force.

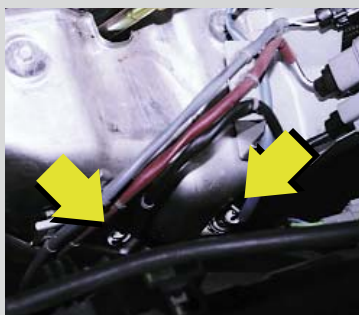
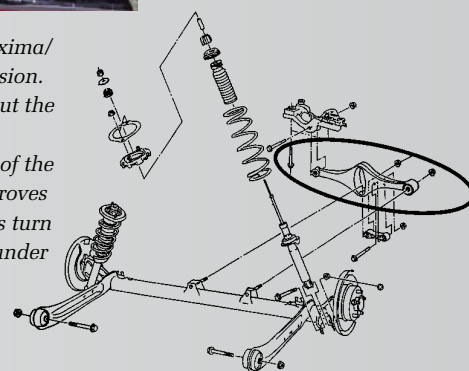

Figure 3: The Sentra 1.8-four has four oxygen sensors, two at top as indicated.

Nissan (continued)

For California, Nissan is offering a Sentra Clean Air (CA) model that is clean enough to earn special emissions credits reserved for SULEV ('super ultra' LEV) — such as electric cars. In fact, this model can be driven on a medium-length trip and run cleaner than an LEV that's standing still. The secrets to these low emissions:

- A zero-loss evaporative emission system. It's sealed, and doesn't use clamps. See **Figure 4**.
- The radiator has a catalytic coating that scrubs ozone from the air flowing through (as on some Volvos).

Yes, the Sentra CA also has a sophisticated emission control system. It has double-wall exhaust, three three-way catalysts, hydrocarbon 'trap' cats, returnless fuel injection and (proving less can be more) a single 'oxygen sensor' in the exhaust manifold — not the two sensors of the 50-states engine. However, this sensor is a linear combustion sensor, far more precise

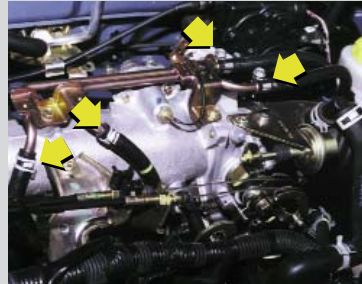

Figure 4: How do you make an evaporative system a zero-emitter? Well, all the hose clamps and the return line you see on this standard Nissan Sentra may look tight, but so are the standards, and every clamped joint might leak ever so slightly.

and faster acting than a toggling oxygen sensor. It's similar to sensors on some Hondas and the Toyota 3.0 V-6. All that catalyst capacity is a restriction, but the CA engine produces just four fewer horses than the regular version — 122 — nothing you can feel while driving. However, the CA must run on low-sulphur gas to achieve SULEV status, and right now California is the only place that's readily available.

The Sentra's optional 2.0-four was tweaked internally for 2000 and develops 145 horsepower (up five) and 136 lbs. ft. torque (up four).

Toyota

Toyota is one of the world's largest automakers, and the flow of totally-new Toyota models is virtually never-ending. The model year started with the Tundra full-size truck, followed by the Echo, Celica and Avalon. A new MR-2 and Sequoia (a full-size sport utility based on the Tundra platform) are also on the way, along with a more powerful Lexus LS (430 hp instead of 400, as the V-8 is larger and more powerful).

For now, we'll take quick looks at what's already out.

Echo

A Toyota for about \$10,000 — sounds unbelievable, and this is nothing skimpy. It's a tall box (good head-room) with funky styling and a high-tech 108-horse 1.5 liter four-cylinder with variable valve timing on the intake camshaft, calibrated to improve low-end torque (105 lbs. ft. peak at 4200). Refer to **Figure 5**. The VVT also produces enough valve overlap to create internal exhaust gas recirculation (eliminating the need for an EGR valve). The engine also has direct ignition over each spark plug (with the ignition coil built into the hard-plastic plug boot as on other Toyota engines). The fuel system is returnless; the sequential injection system uses a hot-wire mass airflow sensor; and the idle speed control is a rotary-valve design. Echo has Toyota's newest vapor control system, with separate trouble codes for large and small leaks.

The overhead camshafts are chain-driven, with an oil-pressure loaded ratchet-type chain tensioner. Although the chain should be long-lived (it's lubed by a specific oil jet) and self-tensioning, there is an access hole in the timing cover to reach the adjuster just in case. See **Figure 6**. Solid valve lifters are used, and with today's metallurgy, they should hold their clearances indefinitely. There are no shims, a design change that Toyota is phasing in. If the clearance needs adjustment, change the lifter itself!

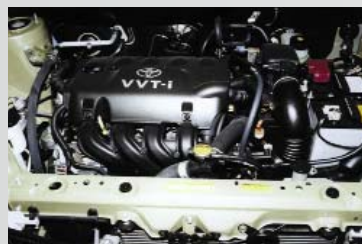

Figure 5: Toyota Echo 1.5 liter engine has VVT-I (variable valve timing with intelligence), a high-tech addition to a low-priced car.

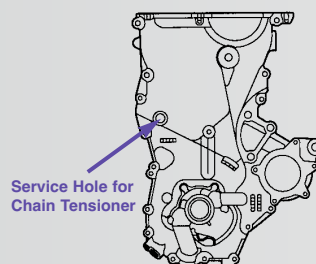

Figure 6: The Echo 1.5 timing chain tensioner operates automatically, with a ratchet-to-hold device. There's also access through the front cover, just in case.

Toyota (continued)

The head bolts are a new 12-point internal design, and although a six-point Allen will fit, it won't provide enough grip and could strip the slot. You'll need new socket bits for these bolts, a fastener design showing up on other Toyotas soon.

One of the more novel design features is that the crankshaft bore center is a half-inch off the centerline of the cylinder bores. As a result, the connecting rod is straight in the cylinders shortly *after* top dead center on the power stroke. This actually is when the power forces on the piston are greatest, and a straight rod means more straight-down force. That reduces the friction losses normally produced by the side forces when the rod is at an angle. Yes, this idea works only on an inline engine.

The Echo also has a dual-path muffler with a spring-loaded flapper, another non-econobox performance feature.

The suspension is conventional Mac strut in front and twist-beam in the rear, but the shock absorber and spring are separate, for more luggage space (and easier service). In addition, the forward bushings in the trailing arms are angled, shaped to provide rear toe correction on cornering. It may not be a multi-link suspension, but remember, this is a \$10,000 car.

The charging system is computer-controlled, so the S terminal for charging voltage is replaced by an (up to) five-volt digital signal at voltage terminal M. That changes the diagnostics, of course, so make sure your electronic information system covers Echo.

Celica (and MR2)

The new Celica is on a modified Corolla platform, so it's no surprise that the standard engine is the chain-driven dual-overhead-cam 1.8 liter, 140-horse four-cylinder (that's 20 horses more than Corolla). However, there's also an ultra-high-performance version that produces 180 naturally-aspirated horsepower, or 100 horsepower per liter. Only the Honda S2000 2.0 liter does better among mass-production engines.

The Celica 180-horse version has variable valve lift *and* timing, matching the long-used Honda design even if executed a bit differently (Figure 7). The Celica 180-horse block also has 'metal matrix' cylinder bores (a reference to the production process that reportedly uses molybdenum and produces a surface that retains oil well). This type, used instead of the cast-iron sleeves of the 140-horse engine, can't be rebored; so if excessively worn, it must be sleeved. Unlike the Echo 1.5, the lifters have conventional shims for valve clearance adjustment.

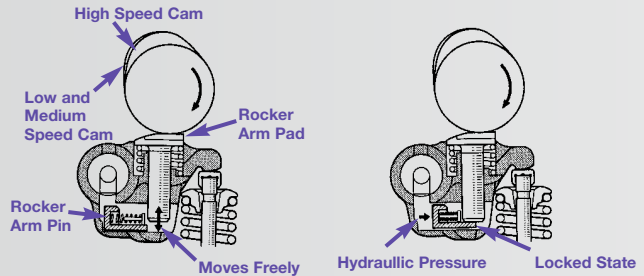

Figure 7: Celica's high-performance 1.8 liter engine has variable valve timing, and, like Honda, variable lift, too. The mechanism is different, but when the oil control valve opens, hydraulic pressure still locks the two intake valves to the high-speed cam, in this case by pushing the spring-loaded pin in the lift assembly as shown.

The two Celica engines have different fuel injectors (not exactly a surprise), a four-hole type for the 140-horse, a 12-hole for the 180.

The Celica has low frontal area, so Toyota has finally given up trying to squeeze a downflow radiator into this model. The new one is a crossflow with a pressurized reservoir (and an air bleed valve on it). The pressure cap is on the reservoir, but it is too low for the system to self-bleed after a flush. The reservoir (under a right front plastic cover) must be raised (it can rest on the hood latch) when filling the system for the air to bubble out. (See Figures 8-9)

There's also a new fuse cluster on the Celica, a combination of four fuses in one housing (Figure 10), designed to provide separate protection for each circuit. It's available only from Toyota dealers at this time.



Figure 8: Celica powertrain compartment has the usual gray 'beauty' covers, and the coolant reservoir is under the one on the right side.



Figure 9: With the Celica beauty cover off, you can see the pressurized coolant reservoir. In this aerodynamic front-end model, the reservoir is not at the high point of the cooling system, so it has to be unbolted and raised (also freeing some hoses after loosening the air cleaner cover). The reservoir can rest on the hood latch.

Toyota Echo prices start at \$10,000, amazing for a car with so many high-tech features, including a 1.5 liter four-cylinder with variable valve timing.



Figure 10: This mini-fuse has six terminals — two power feeds and four power outputs, so it protects four circuits separately.



Figure 11: The Toyota 4.7 liter, 32-valve V-8 is a smooth powerplant for the Tundra pickup.



And although we're not covering the upcoming MR-2, that car's powertrain is shared with the Corolla's, just moved to the midpoint of the two-seater. Hey, are you surprised Toyota knows how to get maximum utility out of its components?

Avalon

The Avalon, restyled for 2000, is a stretched, well-equipped Camry, so you'll find the basics familiar. However, it does have some exclusives, including optional ABS with vehicle stability control (yaw sensing) to help keep the car from fishtailing and dual-zone automatic temperature control. The Avalon 3.0 V-6 develops 210 horsepower, somewhat more than the 194 of the Camry and just under the Lexus ES300's 220 horsepower. Like the ES300 since '99, Avalon has a three-stage (twin-flap) intake manifold and a vibration-canceling, electronically-controlled engine mount.

Tundra

The new Tundra full-size pickup was an early-2000 introduction and has been extremely successful. Pickups are selling well, and one with a V-8 and a Toyota badge could hardly miss. The 245-horse, 32-valve, 4.7 liter V-8 (Figure 11) was introduced in the Lexus LX470/Toyota Land Cruiser in '98, and it's the smoothest V-8 available in any pickup. The base engine is the 190-horse, 3.4 liter V-6 (as used in the predecessor T-100), but few buyers will select this combination. While all the competition is featuring additional models with four full-size doors and a shortened bed with an extender, the only similar Tundra model is an Access Cab with two stubby rear doors. Buyers looking for a four-door Toyota pickup will have to wait, probably for the new Tacoma pickup.

The 4.7 V-8 is based on the Lexus V-8, but it has a cast-iron block because that's needed to sell in the truck market (no 'wimpy' aluminum blocks, thank you, although the camshaft belt-drive might not be considered so tough). It has electronic throttle control (with a linkage setup for limp-home in case of electronic failure). There's a three-catalyst emission control system (two warm-up cats with oxygen sensors before and after each cat, feeding into a third cat with a secondary muffler. The primary muffler at the rear is a dual-path, flap-valve type.

Although the valve timing is unchanged from the Land Cruiser engine version, the Tundra 4.7 V-8 has more sophisticated electronics. So it develops 15 more horsepower (only 230 on Land Cruiser) and almost as much torque (315 lbs. ft. vs. 320) and was calibrated to run on regular gas, compared with premium for the Land Cruiser.

The valve lifters have shim adjusters, but you can't see them simply by taking off the camshaft cover. They're underneath the lifters (Figure 12). Also note the cam cover gasket is a special design — an engineered shape with a double-bead contact (Figure 13).

The rear suspension is leaf spring, of course, and the front suspension (which had been torsion bar on the T-100) is double-wishbone with coil spring on both two-wheel-drive and 4WD Tundra models. The standard shocks are low-pressure gas, but the optional off-road package with 4WD has mono-tube, high-pressure gas shocks. The steering, which had been recirculating ball on 4WD T-100, is rack-and-pinion on all Tundra models.

The Tundra contains a pair of electrical modifications you should know about: The center control panel (which includes switches for the 4WD, cargo lamp and hazard warning, plus HVAC controls) also holds the A/C amplifier. And the driver's side junction block (under the dash) holds the "integration relay," that mostly non-electronic version of a body computer. It controls door locks, power window key-off, horn relay, cargo lamp circuits and the automatic lights-off system.

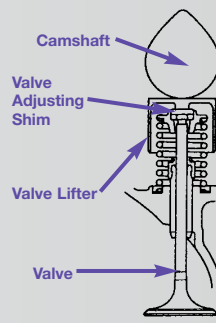

Figure 12: The valve adjusting shims for the 4.7 V-8 are under the lifter, as shown.

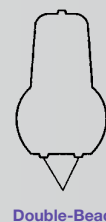

Figure 13: The camshaft cover gasket is an engineered shape with a double-bead.

Volkswagen/Audi

Is Volkswagen turning its high-end cars into lower-end Audis, with moderate differences in engine tuning? The Passat is clearly related to the Audi A4, with a slightly softer ride. And the 2000 Golf and Jetta 1.8 liter 20-valve fours, some with turbos, are transverse-engine models, built on the same platform as the New Beetle and the super-stylish Audi TT. The 1.8 turbo (**Figure 14**) produces 150 horsepower, the same as in the A4, where it's installed north-south. The TT (where it's also installed transversely) gets a version with tuned intake, exhaust and turbo, that develops 180 horsepower.

There are also differences in the interior, feature content and ride characteristics, to try to support the higher price for the Audis. The high performance Audi TT did encounter handling problems, so new sway bars were retrofitted as a factory upgrade worldwide, plus electronic stability control (with yaw sensor) for Europe, where they tend to drive faster. Latest word is that electronic stability control also will be retrofitted to U.S. vehicles.

The 1.8 liter turbo does extend close to the firewall, so service access there is poor. The heater hoses have push-on-to-lock plastic connectors, but you can (with difficulty) remove clamps to disconnect the hoses themselves (**Figure 15**).

The turbo engine has coil-on-plug ignition, but you'll have to remove a beauty cover to see it. VW is adopting the 'bussed electrical center' with seven separate power feeds (**Figure 16**). This design, coming into wider use around the globe, reduces

the number of wires for more reliable wiring connections. The separate power feeds reduce the problems of electrical glitches from current feedbacks.

The 1.8 uses a cast-iron block with a timing belt. The upper belt cover is held by spring clips (**Figure 17**), making it easy to remove for belt inspection. The design is somewhat similar to that on another four-cylinder turbo — the 1.9 liter in the new Volvo 40 series.



Figure 14: It's a Volkswagen Jetta GLS, and the engine label says VW, but catch the reference to a 20-valve turbo. The engine is taken from an Audi A4 and turned sideways, similar to the Audi TT, but with somewhat less power.



Figure 15: The cowl area of the 1.8 turbo is tight, so VW uses push-on plastic hose connectors. The hoses use constant-tension band clamps, so if a hose leaks, replace just it and re-use the plastic connector.



Figure 16: Bussed electrical center on the VW 1.8 turbo permits fewer splices and many separate current feeds, reducing the possibility of electrical glitches in the system.

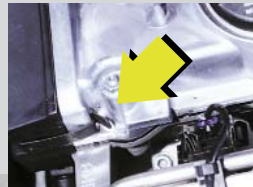

Figure 17: The 1.8 turbo valve cover is held by spring clips at top. After you release them, you can inspect the timing belt.

Volvo

The Volvo 40 series, available as sedan or a wagon, is made in Holland and gives U.S. Volvo dealers a smaller, less-expensive model to sell. It's still a \$23,000 vehicle, but reasonably well-equipped (electronic climate control and keyless entry, for examples) and nicely-finished. The 1.9 liter four's turbo is a twin-scroll, which means there's a separate pressurized-air feed chamber for each pair of companion cylinders (1-4 and 2-3). The all-aluminum 16-valve engine (**Figure 18**) produces a healthy 160 horsepower.

Bosch 5.3 ABS is standard, with four-wheel-discs. Looking for the OBD II connector? A decal under the dash has an arrow to the right, follow it and you'll find the plug in a small cutout against the center tunnel (**Figure 19**).



Figure 18: Volvo 40 series has a 1.9 liter turbo, and it too has a timing belt with the upper cover held by spring clips for inspection access to the belt.



Figure 19: Here's the OBD-II connector, located in a cutout area of the console on the Volvo 40 series.

Honda

The new Honda S2000 convertible is a lot of things a Honda normally is not. It has a north-south engine with a timing chain, not a belt. It's rear-drive with a torque-sensing, limited-slip differential. It's a convertible with a push-button electric top. It has all-electric power steering... and the list goes on.

When you lift the hood, look for the engine dipstick. Before you give up, take out the oil fill cap in the valve cover (**Figures 20 and 21**). Yes, it includes the dipstick, which goes all the way through to the oil pan. Think about the difficulty engineering that one!

The engine revs to over 9000 rpm, and to keep cruising under 5000 rpm, one has to be in sixth gear of the short-throw transmission (the design was borrowed from the Acura NSX). Yes, with a chain this is one noisy engine during normal acceleration; and at \$30,000-plus, this is not a cheap Honda.



Figure 20: The engine compartment of Honda's sports car convertible, with its north-south, 2.0 liter four cylinder that develops 240 naturally aspirated horsepower. Notice the huge air cleaner. The engine revs over nine grand, and at that rpm it really inhales.

Figure 21: The oil fill cap also holds the dipstick. As you can see, the dipstick goes all the way through the engine down to the oil pan.



Honda S2000 convertible has a 2.0 liter four-cylinder that produces 240 horsepower, the highest output per liter of any naturally-aspirated engine. The S2000 six-speed manual gearbox is taken from the Acura NSX.

But the 2.0 liter four with variable valve lift and timing develops an astounding 240 horsepower — 120 horsepower per liter, the highest for a naturally-aspirated mass production engine anywhere. Now you see why it revs so high. This is not an engine to run low on oil, or on which to neglect oil changes. And an engine that turns nine grand draws a lot of air, so check that very large air cleaner at least once a year.

The front and rear suspension components should not sustain jacking loads. Use either the frame rail sections designed for the scissors jack, or the body pan curved reinforcement section in the front (**Figure 22**) or the rear differential banjo in the rear. And because of the torque-sensing differential, don't use the compact spare on the rear driving wheels (use can cause rapid wear in the differential). Instead, switch a front wheel to the rear to replace a rear flat, and put the compact on a front spindle. And if you cut the rear discs with an on-car lathe, use an electric-motor lathe or a motor from an on-car wheel balancer to avoid damage to the differential.



Figure 22: Don't jack up car by the control arms. In front, use this reinforcement (or the reinforced areas on the longitudinal rails, provided for the scissors jack).

Subaru

The conservatively styled 2000 Subaru Legacy and Outback have all-new bodies and other changes. They certainly sell, in large part because of the Subaru all-wheel-drive system standard on all models. You'll appreciate that the new Legacy grille is part of the hood: When you lift it, you have good front-end service access.

The 165-horse, single-overhead-cam, 2.5 liter four-cylinder boxer engine, introduced on Japanese-built Subarus last year, goes into the U.S.-built Legacy. This is a case where one camshaft is better than two, because that permits straighter intake ports and larger valves for low emissions and better low-end-to-midrange torque (although the 166 lbs. ft. peak is at 4000 rpm).

There are two Subaru fuel systems, depending on the model and transmission:

- One for manuals (and all Impreza 2.2s). It has a baro sensor and (new for 2000) an air-assist solenoid valve connected to the inlet of the idle speed control, plus an air intake/pressure sensor. At idle, the solenoid valve opens; and peak air-flow of 20 liters/minute flows to the injectors; off-idle it shuts, and only a 5 liter/minute bleed remains open. This system has a stepper-motor idle-speed control.
- A second system for automatics (and Impreza 2.5 and Forester). This is a simpler design that has a more sophisticated rotary-type idle speed control and a computer software algorithm to do the same job as the air-assist system.

The fuel tank itself was modified for OBVR (on-board fuel vapor recovery, a Federal standard), and for safety was moved under the rear seats, (where, as usual for Subaru, it's a saddlebag design over the driveshaft). So yes, you have to remove the seats (and then access panels in the floor pan) to get to the pump and saddlebags sub-pump. But first remove the drain plug (underneath, on the passenger's side) to drain enough fuel from both. If you don't drain first, you'll spill a lot of fuel inside the cabin when you try to change a fuel pump (**Figures 23 and 24**).

The rear suspension is a new multi-link design, to eliminate the angled-strut mounting that reduced the width of the luggage compartment on previous designs.



Figure 23: The saddlebag fuel tank is under the rear seat, and once the seat is out, you have access to the pump assemblies.

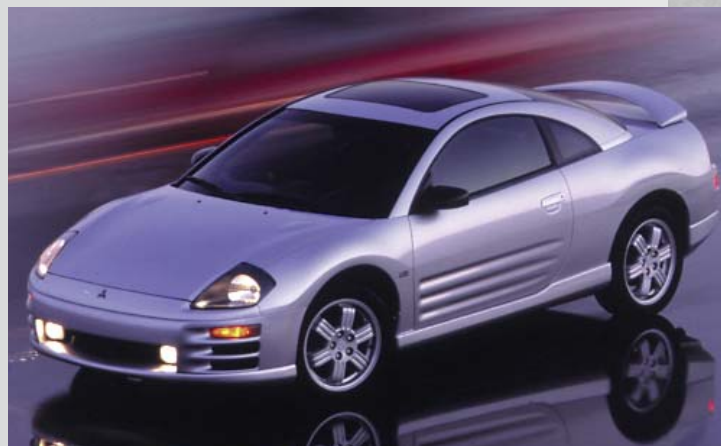

Figure 24: However, you must drain the main fuel tank before you try to get to either main or sub-pump. Remove drain plug shown.

Mitsubishi

The Eclipse is built on the Galant platform, but in previous years it offered a 2.0 liter turbo. The turbo is gone, and the engine choices are straight out of the Galant: the 2.4 four and the 3.0 V-6 with virtually the same engine compartment layouts. The body is all-new for 2000; the chassis is new and super-stiff. The multi-link rear suspension is a carryover, but with tubular steel control arms instead of stamped steel. The front suspension is a reworked MacPherson strut, with a new swaybar. There's a die-cast aluminum crossmember for the V-6.

Mitsubishi Eclipse is totally restyled for 2000, and its 2.0 liter turbo has been dropped. Instead, it's powered by the 2.4 liter four and 3.0 V-6 engines used in the Galant, on which platform the Eclipse is built.



Mercedes-Benz

Mercedes has been marketing high-performance versions of all its popular models, C-class, E-class, even the M-class, featuring highly-tuned engines by AMG, now a Daimler-Benz affiliated company. But the truly innovative engineering is the active suspension (**Figure 25**) in its new C-coupe (not C-class, but a premium model based on the S-class). The CL-coupe is no wimp. It has the 5.0 liter V-8, which produces 302 horsepower.

The C-coupe may not be high-volume for openers, but Mercedes did not engineer this amazing suspension for long-term low volume. Consider this your 'heads-up.'

A truly-active suspension system has been in the works at every vehicle manufacturer for many years. Nissan tried it on the Infiniti Q45 years ago, but all that did was add \$5000 to the price. Drivers couldn't tell the difference. The one on the new Mercedes C-coupe figures to be something that drivers *will* notice. It's extremely sophisticated, far beyond the computer-controlled anti-roll hydraulic system introduced by Land Rover last year.

Each wheel has a suspension unit that consists of a strut with a hydraulic piston on top. Changes in road texture, cornering, etc., trigger a computer-controlled valve block at front and/or rear, which modulates hydraulic pressure to each of the pistons. The piston movement is the key control — it determines the angle of the car. It also compresses the spring when it applies pressure, so it can change the spring rate too. The gas-filled shock absorber at the bottom of the suspension unit does what every shock absorber does — dampens spring oscillation.

Sounds simple, but it takes an engine-driven oil pump to

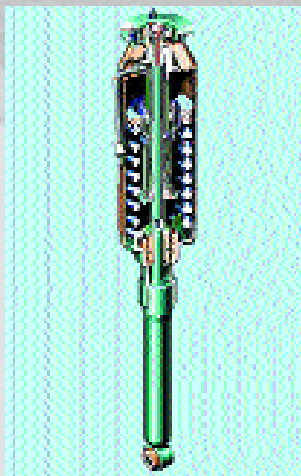

Figure 25: Mercedes CL-coupe suspension unit, computer controlled, uses the piston assembly at the top to position that corner of the car. The hydraulic pressure to the piston is from an engine-driven pump, through computer-controlled valve block assemblies at front and rear. The "position magnet" in the suspension unit is a piston position sensor that provides feedback to the suspension computer.

produce the hydraulic pressure, and complex valve blocks front and rear to modulate the pressure precisely and instantly to each piston. Each valve block includes a pressure sensor, pulsation damper and pressure relief valve. A computer controls the valve blocks, based on signals from lateral and vertical acceleration sensors, and from suspension level sensors — one at each wheel. The 'secret' behind a successful active suspension is not merely a bunch of sensors and computer-controlled valves. It's designing a system that responds instantaneously to changes in road conditions and cornering — with no lag anywhere.

As you read this, more new models are being introduced. Fortunately, rationalization of platforms and powertrains means there's also a lot of 'under-the-skin' commonality. That helps the technician with special tools and equipment. However, there are also important differences between 'fraternal-twin' models, so load your latest tech service CD's and read before you work. ■

— By Paul Weissler