



Innovation
that excites

Winter 2015 | Volume 8 | Issue 1

TechNews

- | **EPS**
- | **MR16DDT**
- | **Ignition Switch**
- | **Matte Finish & Carbon Fiber**



*Brought to you by your local Wholesale Mechanical
and Collision Repair Network Dealers*



Innovation that excites

Delivering More, for Less.



The Right Parts

– Improve cycle time and deliver high customer satisfaction.

The Right Price

– Many popular collision parts now available at 35% off MSRP*

Right Now

– Your Nissan dealer has the best inventory of Nissan collision parts ready for quick delivery.**



Genuine Nissan and Value Advantage™ parts deliver the fit, function and performance you and your customers expect. Now with 35% off* everyday low pricing on many of our popular collision parts there's no excuse to settle for anything else.

parts.NissanUSA.com

*See participating dealer for details. 35% off MSRP for eligible popular parts only. MSRP excludes all applicable taxes. Participating dealer sets actual price. **Contact your local dealer for order details and times. Exclusions apply. Subject to part availability.

Nissan, the Nissan Brand Symbol, "Innovation that excites" tagline and Nissan model names are Nissan trademarks. ©2015 Nissan North America, Inc.



Nissan Tech News is a publication of Nissan North America. No part of this newsletter may be reproduced without the express written permission of Nissan North America.

Group Publisher

Christopher M. Ayers Jr.
cayers@automotivedatamedia.com

Editorial Director

Bob Freudenberger
bfreud@automotivedatamedia.com

Managing Editor

Tom Nash
tnash@automotivedatamedia.com

Contributing Editors

Bob Chabot
bchabot@automotivedatamedia.com

Paul Cortes
pcortes@automotivedatamedia.com

Phil Fournier
ffournier@automotivedatamedia.com

Christian Strohm
cstrohm@automotivedatamedia.com

Art Director

Christopher Ayers III
ayersc3@automotivedatamedia.com

Nissan North America

Project Manager
Leslie Ohrin
WMPPProgram@nissan-usa.com

**Nissan North America
Technical Content Advisors**

Dave Willson
dave.willson@nissan-usa.com

James Von Ehr
james.vonehr@nissan-usa.com

Editorial and Circulation Offices:

134B River Road
Montague, NJ 07827
Phone: 330.620.3929
www.automotivedatamedia.com

Caution: Vehicle servicing performed by untrained persons could result in serious injury to those persons or others. Information contained in this publication is intended for use by trained, professional auto repair technicians ONLY. This information is provided to inform these technicians of conditions which may occur in some vehicles or to provide information which could assist them in proper servicing of these vehicles.

Properly trained technicians have the equipment, tools, safety instructions, and know-how to perform repairs correctly and safely. If a condition is described, DO NOT assume that a topic covered in these pages automatically applies to your vehicle or that your vehicle has that condition.

Contents

Features

04 | The MR16DDT

A look at the MR16DDT turbocharged, direct-injection gasoline engine in the JUKE, covering the engine design, direct injection system, turbo, and continuously variable valve timing.



12 | Whatever Happened to the Ignition Switch?

A little confused about how Nissan ignition systems function? Here's the help you need.



18 | Nissan Electronic Power Steering

EPS is becoming common on Nissan vehicles. Here's some technical information and help for when the PS light comes on.



24 | Matte Finish and Carbon Fiber

The low-gloss matte exterior and carbon fiber bumper fascia and accent body panels are a challenge for collision repair specialists, unless, of course, you pay attention to the step-by-step refinish instructions.



Departments

| 32 Nissan Dealer Listings

Feature

The MR16DDT

Small Displacement, Big Output



A look at the MR16DDT turbocharged, direct-injection gasoline engine in the JUKE, covering the engine design, direct injection system, turbo, and continuously variable valve timing. Also, a few service procedures and diagnostic considerations for this engine.

The Nissan JUKE comes standard with advanced engine design and engine management systems that may become much more common across all manufacturers. The reason is simple: the MR16DDT engine achieves a great balance of power, fuel efficiency and low emissions. Automobile manufacturers are under constant pressure to reduce their vehicles' emissions while increasing fuel efficiency. These gains are almost always at the cost of engine power and performance. The engineers at Nissan have developed an all-aluminum, 4-cylinder, 1.6L engine that boasts 188 hp and achieves approximately 27 mpg in a 3000 lb. JUKE.

The MR16DDT utilizes many technologies to achieve its excellent power-efficiency-emissions balance:

1. Advanced internal engine mechanical design
2. Extraordinary fuel control through gasoline direct injection (DIG)
3. Continuously Variable Valve Timing (CVVT)
4. Forced air induction through turbocharging

The JUKE also utilizes a high-efficiency automatic transmission, intelligent throttle control, and other vehicle-specific systems.



The CVVT system improves fuel efficiency and maximizes performance.

It's also worth mentioning that the Nissan JUKE NISMO edition further improves the performance of the stock MR16DDT with ECM tuning and modifications to nearly 100 individual components. The NISMO RS can output 215 hp, thanks to increased exhaust flow from larger diameter piping, enhanced ECM tuning, reinforced piston connecting rods, and a limited slip differential to ensure the power meets the ground.

Shiny on the Inside! Upgraded Engine Mechanical Parts

Friction is an ever-present tax on the efficiency of machines. From the movement of the pistons to the rotation of the crankshaft, there is friction in every tiny engine motion. Every bit of power lost due to friction further reduces the net efficiency of any internal combustion engine. The MR16DDT reduces friction by polishing the cam and crank journals to a mirrored "Nano-finish."

Heat management of internal engine components is a critical consideration for reliability and longevity. Using a design typically reserved for high-performance applications, the MR16DDT has hollow, sodium-filled exhaust valves. Like shaking a ketchup bottle, as each valve moves, the force pulls the liquid sodium toward the stem or the face. This facilitates the movement of heat away from the hotter face, and reduces mechanical wear. Sodium is a reactive metal, and there are necessary safe handling steps to manage valve disposal after repairs. They must be

broken in half and "defused" in a controlled situation. Consult the repair manual for exact steps.

The design of the intake manifold is tied closely to the engine's optimal operating speed. The MR16DDT has acoustically equal intake runners that sport secondary "tumble" valves. The tumble valve controller can adjust the runner length as needed by the ECM to introduce turbulence when the engine is very cold or idling. When closed, the runners are shorter and the velocity of the air charge is greater. Upon entering the cylinder, the swirling air charge promotes better coalescence with the fuel charge and can also improve the burning speed of the mixture. When open, the runners are longer and the length of the runners is tuned to reduce intake flow resistance. The acoustically equal runner design also adds to the joy of driving by reducing the often rough sounds of intake and dramatizes the pleasant sensation of acceleration.

Along the same lines of driver experience, the MR16DDT is equipped with a "silent" timing chain design. The naturally occurring impact noise of chain-to-sprocket mesh is lessened by spreading the impact points from just the pin of the chain to other points on the cam sprocket. Distributing the impact lessens the sewing machine type sound.

The MR16DDT runs at 9.5:1 compression ratio, with a bore and stroke of 79.9mm by 81.1mm. It calls for 91 octane gasoline for best performance. Lower octane fuel can be used, but with potential losses to power and efficiency. It is lubricated

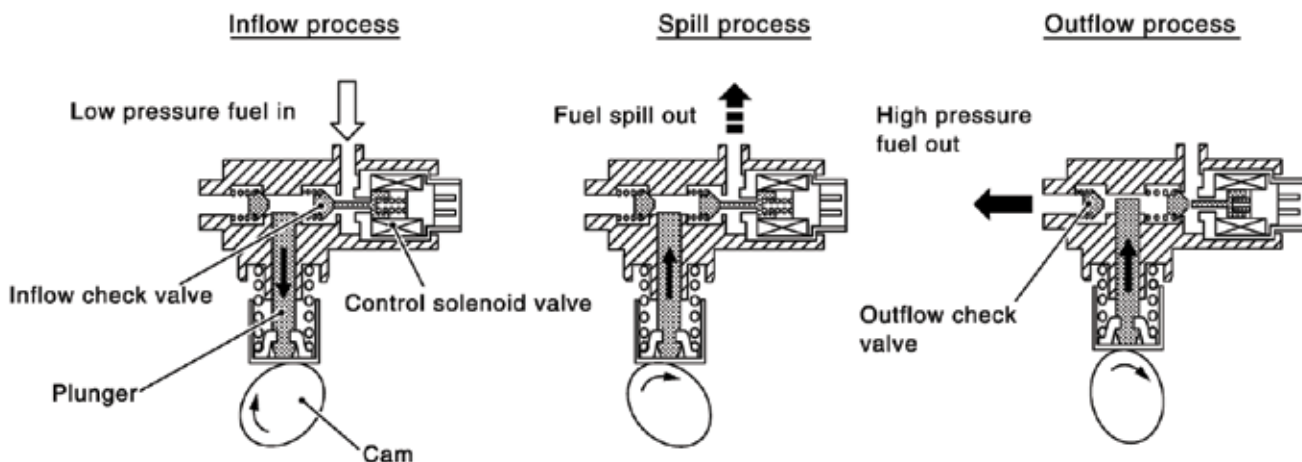

The ECM manages high fuel pressures by actuating the control valve solenoid and its one-way valve.

with 5W-30 API SN oil, and cooled using Nissan Genuine Long Life Blue Coolant. Ignition is achieved using long life iridium-tipped spark plugs and direct ignition coils.

Gasoline Direct Injection (DIG)

Gasoline direct injection is becoming more popular. Here, we'll focus on the design specifics of the MR16DDT engine in what Nissan refers to as DIG. High pressure fuel injectors are located in the side of the head, and are controlled by the ECM in two ways. The first notable difference from conventional fuel control is that rather than grounding the injectors, the ECM provides up to 65V to power them to spray when necessary. Second, the ECM commands the high pressure fuel pump control valve solenoid to adjust the pressure – and therefore volume – of the spray. Having such fine control over fuel delivery is truly what makes direct injection such a step forward.

There are high and low pressure sides of this direct fuel injection system. The low pressure side of things looks very much like a traditional design: an in-tank fuel pump provides constant fuel pressure available to the second, high pressure fuel pump mounted on the head. At idle, the low pressure fuel pump should generate 73 psi. Note that special service tools are necessary to remove the low pressure fuel pump on all Nissan vehicles (KV101207S0 & KV99110600 for pump lock ring removal). All evaporative emissions components are

also low pressure, and purge occurs into the intake air charge, as is typical.

Things get interesting on the high pressure side of the equation. A mechanical high pressure fuel pump is attached to the exhaust camshaft and receives fuel from the low pressure side. The high pressure pump forces fuel into the fuel injector rail where pressure builds and remains present even when the vehicle is turned off. A fuel rail pressure sensor (FRP) reports available pressure to the ECM in the form of voltage. Using CONSULT, you can check live data for this information. Expect to see ~400 psi at idle, or about 1.14V.

Fuel rail pressure will vary based on the calculated demand for fuel. By modulating the high pressure fuel pump control solenoid, the ECM can adjust how much high pressure “spills” back to the low pressure side. By default, pressure will be low; upon solenoid activation, a one-way valve will close and prevent spillage to increase pressure. As solenoid on-time increases, the greater the rail pressure will build. More fuel per injection event will be delivered when rail pressures are higher.

The amount of fuel injected is a program value stored in the ECM based on engine operating conditions determined from input signals generated by the crank position sensor (POS), camshaft position sensor (PHASE), mass air flow sensor (MAF), FRP, and turbo boost sensor. Higher load, faster engine speeds, everything that you would expect to demand more fuel is picked up by the ECM and the fuel pressure adjusted. As with most cars, a feedback

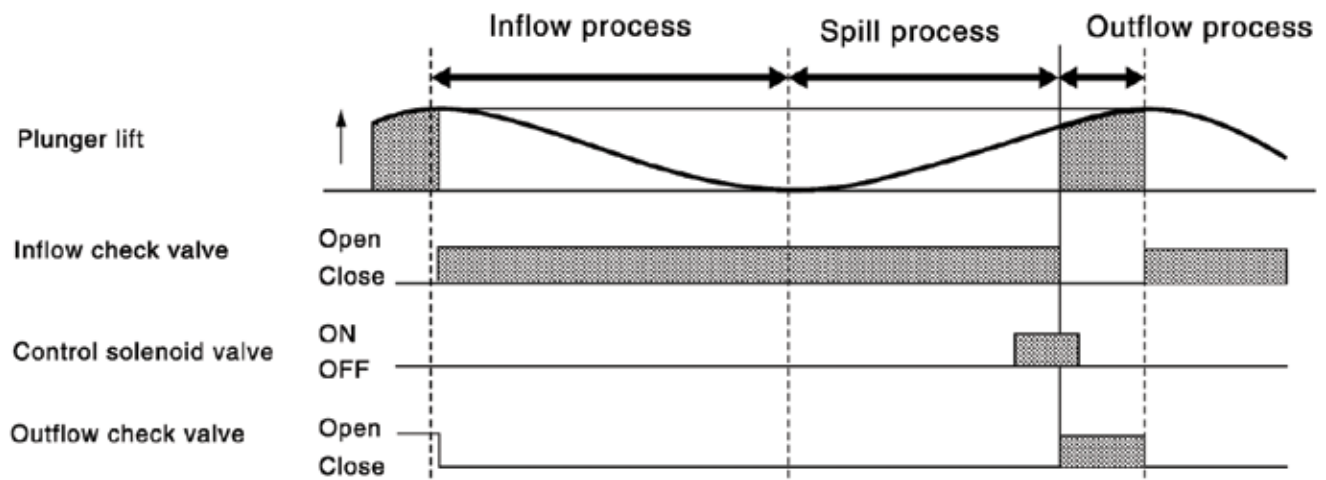

The ON time of the control solenoid dictates the outflow event duration.

loop is established using air/fuel ratio sensors to maintain stoichiometric balance.

The ECM can also modify fuel injection behavior based on special operating conditions. For example, more fuel is added during starting, acceleration, hot engine operation, shifting the CVT from neutral to drive, and high load. Less fuel is added during high speed cruising, and no fuel is added during deceleration.

Direct injection allows for a technique called stratified-charge combustion. The timing of the fuel injection event is delayed, and the amount of fuel is diminished to extremely lean numbers. At the end of the compression stroke, the small very rich injection charge is sprayed directly at the spark plug. The final mixture is local to the plug electrode, but surrounded by lean mixture. The ignition event creates a flame front from the rich mixture, igniting the remaining air. As a result, a less homogenous air-fuel mixture is needed for compression and combustion, which saves fuel overall. The MR16DDT will utilize this technique whenever the engine is cold (ECT reads 41°F – 104°F). Stratified-charge combustion increases the rate of warm-up and improves emissions. At all other times, the air-fuel mixture is comparable to similar modern engines.

The injectors themselves are installed directly to the side of the cylinder head. Removal and reinstallation of these components requires special service tools. Due to the high pressure nature, incorrect repair procedures can introduce potentially hazardous fuel leaks. Always refer to the service manual before attempting repairs.

As fuel pressure is ever-present within the rail, a special fuel pressure release procedure is necessary prior to work. Using the CONSULT, connect to the ENGINE computer sub-category, choose WORK SUPPORT, then perform FUEL PRESSURE RELEASE. Start the engine, and after it stalls, crank 2-3 more times to release all pressure. Turn the ignition off to complete the procedure and begin work. Do not restart the engine.

Continuously Variable Valve Timing

Overcoming the physical limitations of valve overlap timing has always been a discussion of trade-offs

for engineers. Do we design the engine with high valve overlap for high RPM range operation? Should the engine be tuned for better low and mid-range efficiency? Implementations of variable valve timing

Figure 1-4: Special service tools remove the press-fit injector and install the suitable replacement seal ring.

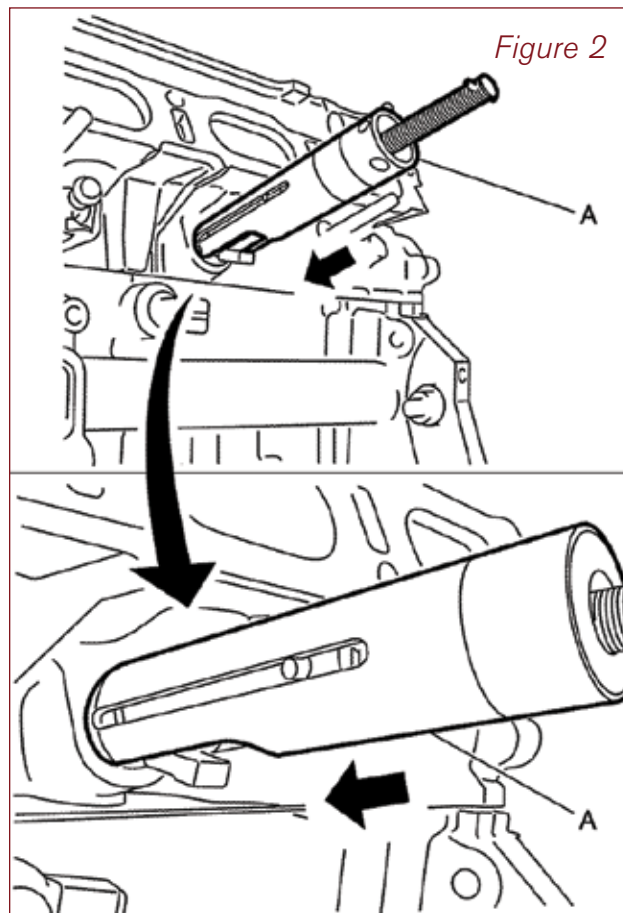
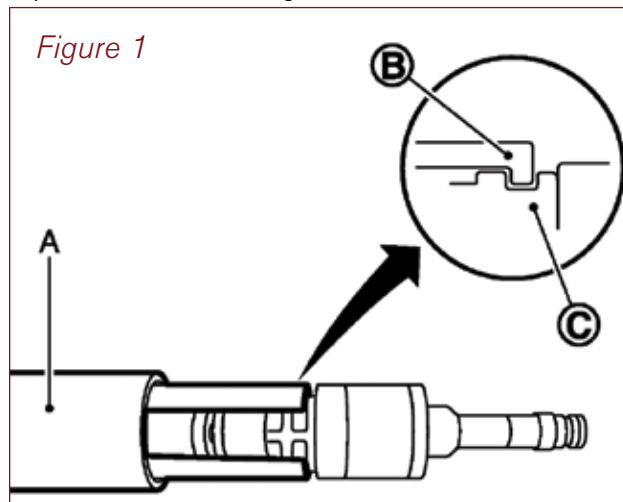

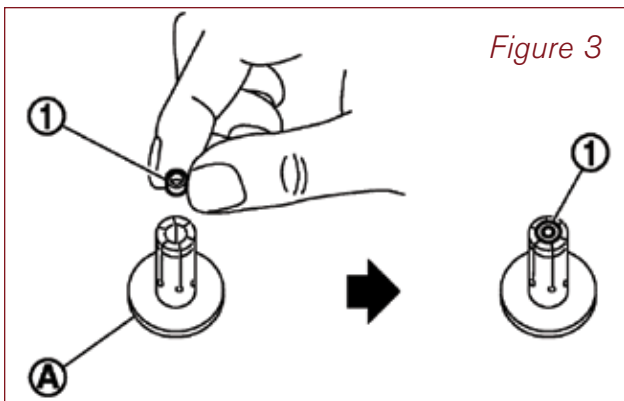

Figure 3

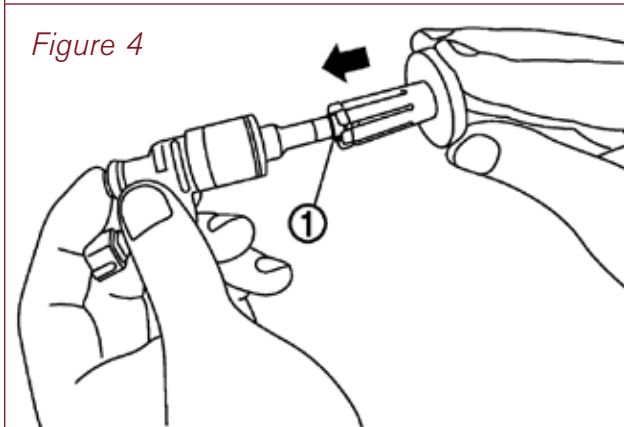

Figure 4

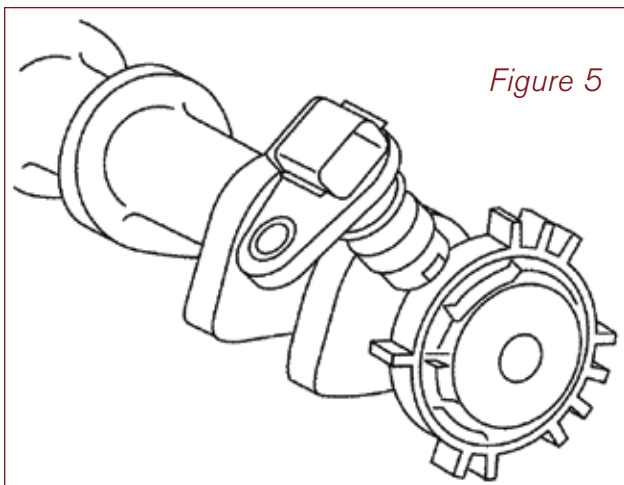
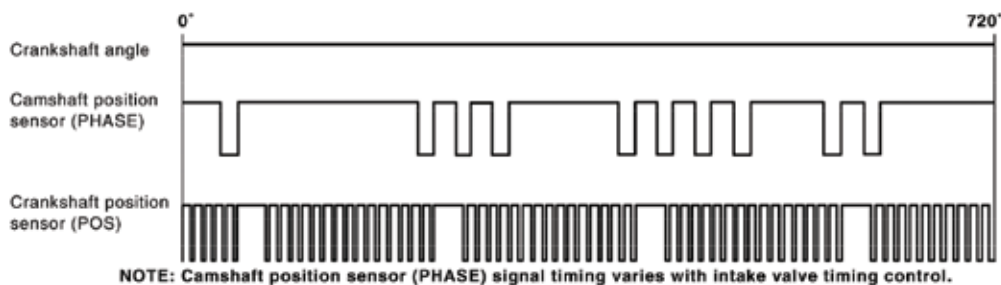

Figure 5



The unique design of the PHASE sensor plate (Figure 5) makes for more informative graphs (above).

have been around for quite a while, but Nissan's CVVT design allows for significant control over intake and exhaust valve overlap.

Both the intake and exhaust camshafts are engineered with the CVVT sprocket on the timing chain side, and a sensor plate on the other. Each sensor plate has teeth whose rotation past a Hall Effect sensor induces a digital voltage signal that the ECM uses for timing purposes – nothing strange there. However, the intake camshaft sensor plate is unique; it has a number of teeth based on the cylinder firing order. This is reported by means of the PHASE sensor, which would have traditionally been called the camshaft position sensor (CMP). On the exhaust camshaft, the sensor plate has four equidistant teeth, and the exhaust valve timing control position sensor generates a traditional-looking square wave.

The PHASE sensor can also function in place of the crank position sensor in the event of malfunction.

The ECM can advance or retard both intake and exhaust cams by using oil pressure to actuate the appropriate sprocket in the necessary direction. The exhaust valve timing (EVT) control solenoid changes the valve angle of opening based on the pulse duty ratio signal from the ECM: shorter signals advance, longer signals retard timing. The signal moves the valve within the EVT control solenoid to allow for oil pressure to flow in a combination of two directions: toward advanced or retarded. Oil can also flow out a drain for displacement. There is a return spring applying pressure within the sprocket toward a rest state.

If the signal pulse widths are equivalent, both control solenoids will hold their sprockets in a stable position. The intake valve timing (IVT)

control solenoid operates identically to the above-described EVT control solenoid, except that the pulse length behavior is opposite: longer signals advance intake timing, and

shorter signals retard. Also, the direction of the return spring force is opposite.

With the CONSULT, technicians can verify the current cam sprocket angle using live data. INT/V TIM at idle should be between -5 and 5 degrees cam advanced (CA), and between 0 - 20 degrees CA at 2000 rpm. EXH/V TIM is identical at idle, but at 2500 rpm and rising, exhaust timing should be between 0 - 30 degrees CA.

The most commonly observed failures with any variable valve timing system is lack of oil pressure. Without sufficient oil pressure, VVT cannot operate, and the MIL will illuminate with potentially misleading faults pertaining to valve timing. Check engine oil level first before chasing a cam timing code down the rabbit hole.

Turbocharger

Forced induction is a simple method of improving engine performance without increasing

displacement. The MR16DDT has great power per liter as a result of turbocharging. Let's skip over how turbo works in general, and instead focus on the specific boost control methods used by this particular engine.

Whenever the throttle valve is shut completely, the turbo-produced intake air charge doesn't just stop and wait for the door to open again. Pressure will back up, accumulating in the intercooler. Eventually, pressure can stall or reverse the direction of the compressor turbine. This can put heavy stress on the turbine bearings and fins, which may reduce reliability and longevity of the parts. The MR16DDT mitigates chances of so-called compressor surge with computer-managed boost control.

The boost sensor is a second intake air temperature sensor that lives on the outlet side of the intercooler. It can also sense pressure, which it sends to the ECM in form of a voltage signal

Flow control diagram for CVVT exhaust sprocket.

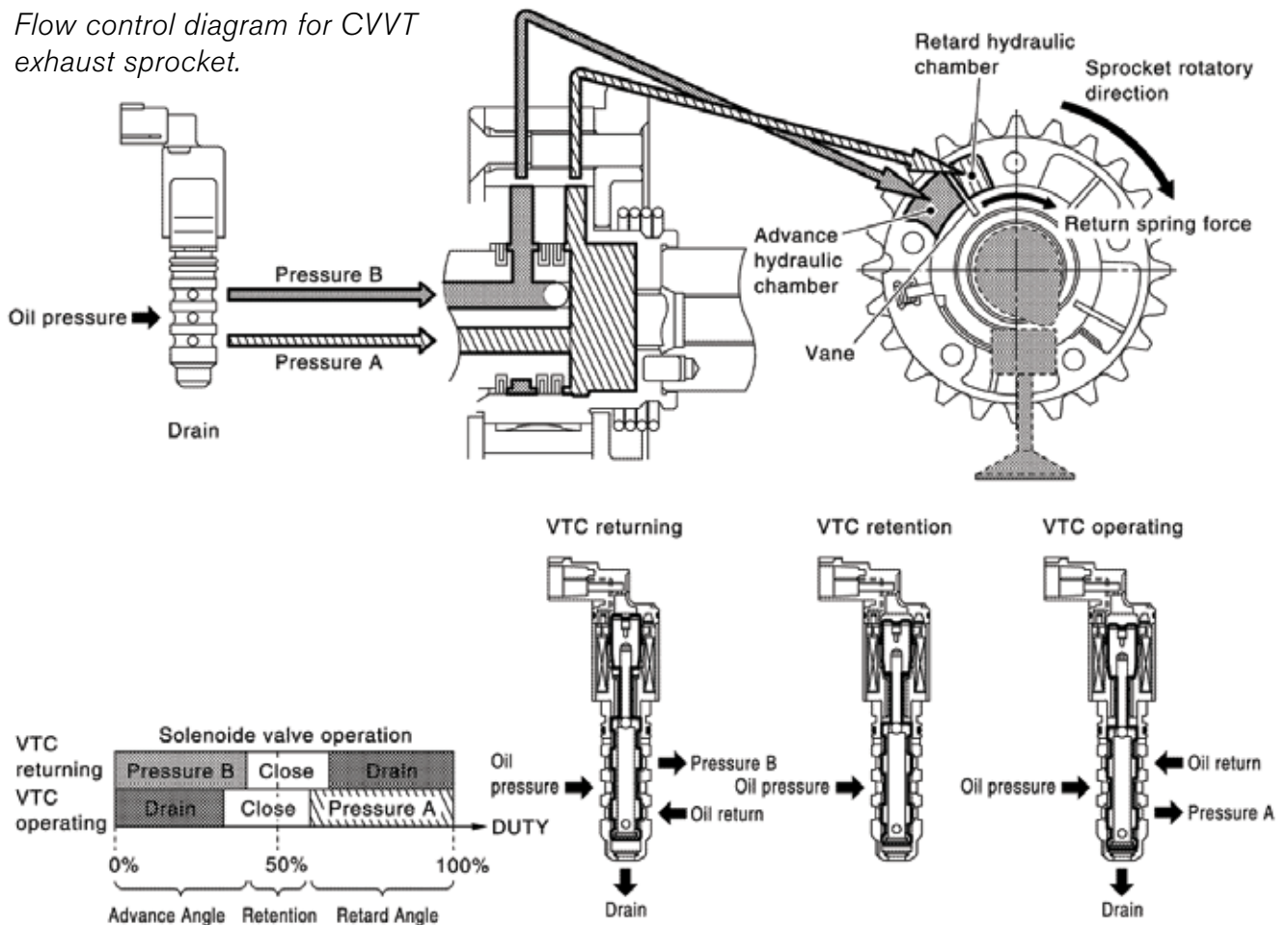

(higher voltage is higher pressure). The ECM will observe pressure and appropriately route exhaust gas toward the turbo inlet for increased boost, or back into the intake through the recirculation valve for decreased boost. To adjust boost, the computer commands the boost control solenoid to change pressure against a diaphragm within the boost control actuator. Longer duty cycle to the boost control solenoid moves the diaphragm open, which in turn increases the exhaust flow to the turbo inlet.

Technicians can use the CONSULT to check the commanded boost solenoid value in live data. BOOST S/V should read 0% at idle. With the accelerator pedal depressed at least half travel, BOOST S/V should read 100% below 3000 rpm and somewhere between 30-60% over 3000 rpm.

Fail-Safe Mode

Various MIL faults will induce a fail-safe mode. Check the repair manual for details. For example,

P0045 (boost control solenoid circuit) sets the boost actuator to zero boost by default. P0190 (FRP sensor circuit) opens the high pressure fuel pump solenoid at all times to provide full pressure at the fuel rail. P0087 (FRP control circuit) may cause limited power due to incorrect fuel pressures. As with any diagnostic approach, begin with the service manual and common sense before reaching for complicated explanations.

2015 Generational Changes

The second generation of the MR16DDT is standard on 2015 model year JUKE and JUKE NISMO editions. You will find a different spark plug, a lighter-weight 0W-20 synthetic oil, changes in the engine management system, and different driveline lubricants (and CVT options). The net effect is a 1-2 mpg fuel economy improvement and 10 increased horsepower and torque. |

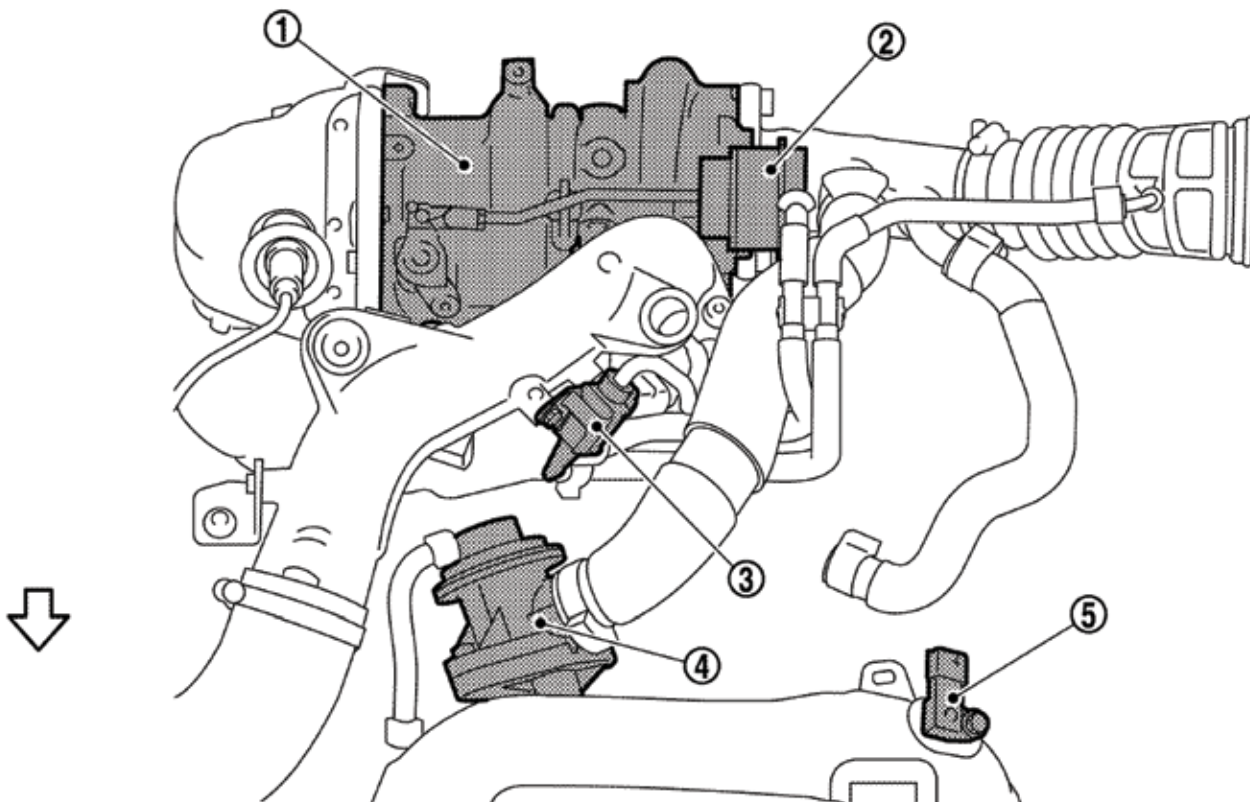

The turbo's (1) boost is managed by the computer's signal to the boost control solenoid (3) based on input from the boost sensor (5). The boost control actuator (2) will then route a percentage of the exhaust gas into the turbo, or back through the recirculation valve (4).

Whatever Happened to the Ignition Switch?

A little confused about how Nissan ignition systems function? Here's the help you need.





From the dawn of production automobiles, switches were used to provide power to the ignition system and any other electric components. As stealing horses gave way to stealing cars, a lock was added to the ignition switch to prevent someone from driving off in your new car. This simple version of the locking ignition switch has been around for nearly a century now, but you may have noticed that it's disappeared on many Nissan products.

Providing power to all the electrical systems is now a responsibility shared by a few different components: the IPDM (Intelligent Power Distribution Module), the BCM (Body Control Module), the ECM (Engine Control Module), the Fuse Block, and the Start Button or Ignition Switch. These components make up the PCS (Power Control System) and take over the traditional role of the ignition switch.

In this article, we'll focus on the PCS (the switch), and ignore the immobilizer and I-Key systems (the lock). The information in this article will be based on the very popular Altima, but will be very similar to the systems found in other Nissan vehicles.

If it's Not Broke, Why Fix it?

Why bother changing a component that's worked for so long? There are several reasons:

- Less wiring; there's no need to run as many thick wires and inputs can be shared via a network.
- Less current and heat in a single component making failure less likely.
- The ability to integrate the Intelligent Key System for passive entry and starting.
- Self-diagnostic capabilities make intermittent "switch" problems easier to diagnose.
- A battery saving feature to prevent the 12V battery from discharging.
- Current sensing and self-protection features to prevent damage from shorts, frozen electric motors, and other sources of over-current.

Meet the PCS Team Members

The Push-Button Ignition Switch or Keyed Ignition Switch

The Push-Button Ignition Switch or the keyed Ignition Switch perform the same function: both are inputs for the BCM, which relays their status to the IPDM via the CAN bus. Of course, a vehicle will only have a push button or a key, not both. On vehicles with a keyed ignition switch, the switch isn't like a conventional ignition switch. It doesn't carry any real current, it's just a signal to the BCM. The push-button or keyed switch is also a BCM output. The BCM turns on LEDs in the button or on the switch bezel to indicate the current power mode: OFF, ACC, ON, or READY/RUNNING

The Accessory (ACC) Relay

The Accessory Relay provides power to the systems normally powered by the ignition switch while in the ACC position, such as the audio system, power windows, power ports, and the user interfaces for climate control and navigation. The Accessory Relay winding is powered by the BCM based on input from the ignition switch. If the control side of the relay circuit fails, a B2611 trouble code will set. If the switched side of the relay circuit fails, a B2614 will set. These trouble codes make diagnosis of intermittent problems a lot easier. The ACC relay can be removed and replaced independently if needed.

The IPDM – Intelligent Power Distribution Module

The IPDM is located in the engine compartment on the Altima and many other cars. In the manual, you'll notice that it's called the IPDM E/R. The "E/R" stands for Engine Room. The IPDM detects the ignition switch position (button or key) and sends that information to the BCM via CAN. Once the BCM receives the switch position information, it can request the IPDM close its internal Ignition Relay #1, which powers up several ECUs, the fuel injectors, and several lights.

The IPDM also houses several other relays for the wipers, cooling fans, and AC compressor. The relays in the IPDM cannot be removed from the IPDM, so don't attempt to pull them for testing because it will damage the unit. If an IPDM relay fails, the unit must be replaced. Like the ACC Relay, each of the relays in the IPDM is monitored for faults and will set a trouble code if there is a failure.

The IPDM also contains two relays for starting: the Starter Relay and the Starter Control Relay. The Starter Relay coil is grounded by the BCM, powered by the Transmission Range Switch or the Neutral Safety Switch. The Starter Control Relay coil is powered by the Starter Relay and grounded by the IPDM. You may have noticed that you don't need to hold the key in the start position until the engine runs on newer cars. Once the key is turned to the start position, even briefly, the Starter Control Relay is held closed until the engine starts. If the engine cranks for an excessive period and the engine does not start, the relay will be opened to protect the starter motor from overheating.

The Chain of Command

The IPDM is a lot smarter than a relay block, but doesn't make most decisions on its own. The BCM and ECM issue most orders via the CAN bus. Instead of running one wire for each desired output, as would be necessary with a simple relay block, all orders from the BCM and ECM are sent via the CAN bus, which only takes two wires.

The IPDM controls the generator output via a modulated pulse width (PWM) signal. The ECM issues a charge request to the IPDM via the CAN bus, then the IPDM sends

a PWM signal to the generator. The ECM also controls the cooling fan speed through the IPDM in the similar fashion. A CAN message is sent to the IPDM, then the IPDM commands low and high speed operation of the fan by energizing the appropriate relay.

The Body Control Module issues commands to turn on or off various circuits powered by the IPDM. The headlight relay, tail light relay, fog light relay, ignition relay #1, and starter relay are usually commanded on or off by the BCM. The ECM also commands the IPDM to power or depower circuits. The ECM controls the AC relay, fuel pump relay,

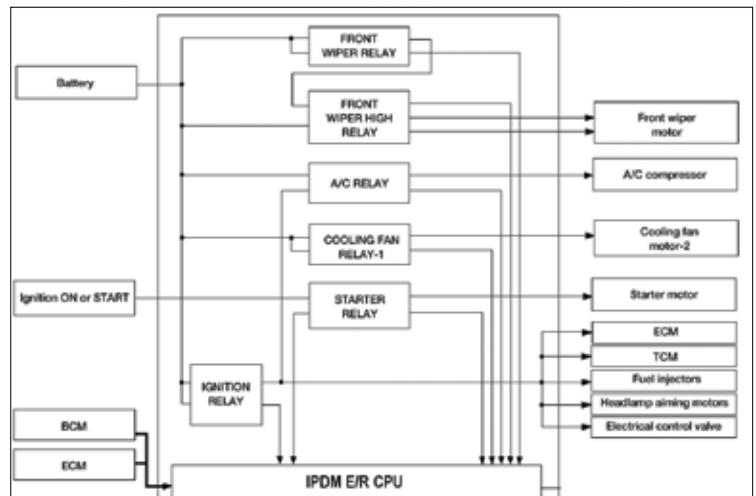

IDPM Relay diagram]

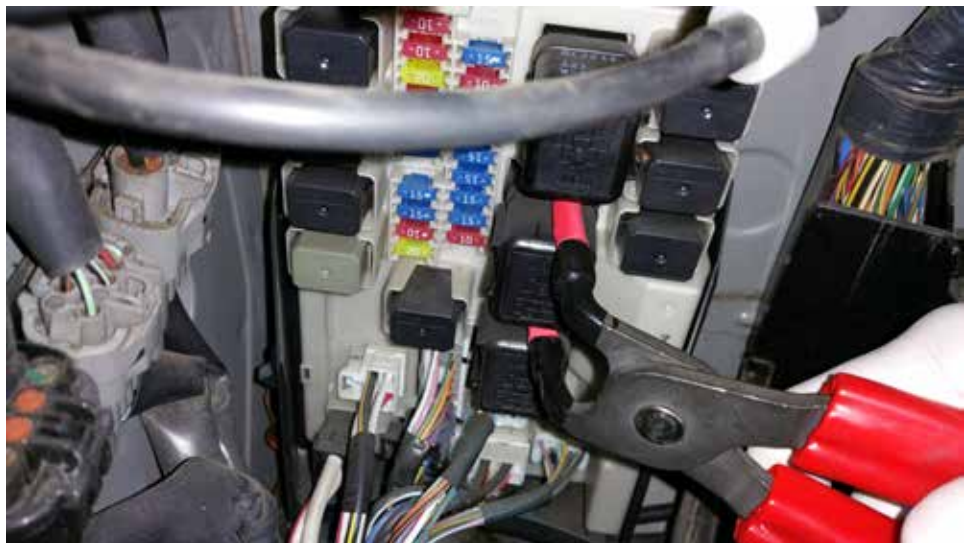

Unless you want to buy your customer a new IPDM, don't try to remove the integral relays. You'll damage the unit!

throttle motor relay, cooling fan relays, and in an odd bit of bootstrapping, the ECM relay.

In the event of a loss of network communication, the IPDM will make some decisions on its own. This is called failsafe control. When the IPDM loses its “eyes and ears,” it defaults to actions that will allow the vehicle to be driven to a shop. If its connection with the ECM goes down, the IPDM will run the cooling fans whenever the ignition switch is on, it will turn off the AC compressor coil, and it will command the alternator to charge. If the connection with the BCM is lost, the headlights and other illumination will be turned on, the wipers and ignition will continue to function at their last state before communication was lost and the horn, fog lamps, and starter motor will not operate.

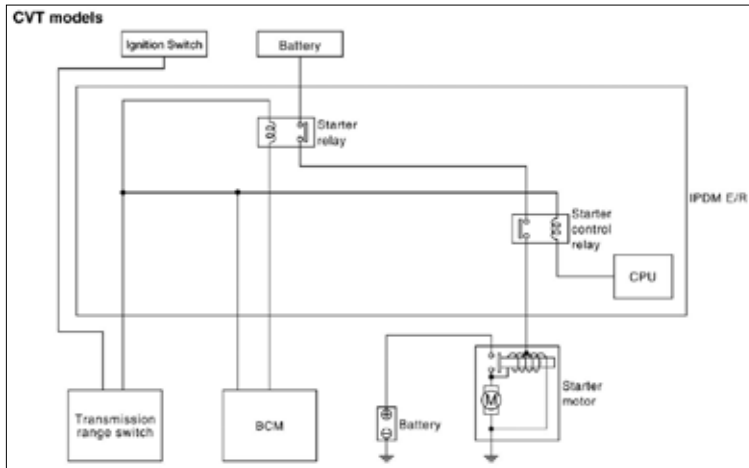

Starter Relay diagram.

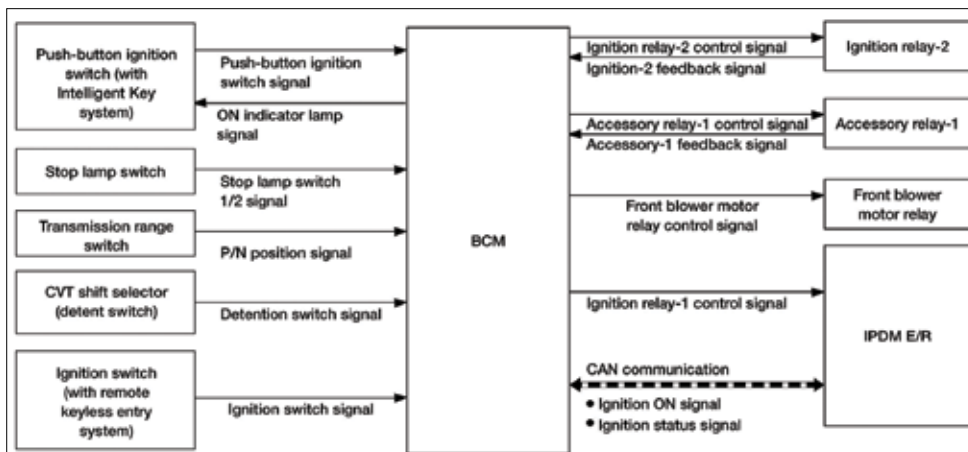

BCM diagram.

The System Benefits

I is for Intelligent

The IPDM does make some decisions on its own without consulting the ECM and BCM. One of its autonomous functions is self-preservation. The bane of control units and relays is low resistance in an output circuit. Low resistance means high current flow. High current flow means heat and oxidation of conductors and melting plastic (bad stuff for relays, transistors, and connections). The IPDM uses Smart Field Effect Transistors (FET) to limit the current output and temperature to protect itself from damage in some circuits.

Saving Power

Staying awake takes energy. The IPDM is able to go to sleep and save power when there's not a lot going on. The IPDM doesn't decide to go to sleep on its own; the BCM issues a sleep command via the CAN bus and the IPDM drops into a low power mode. As long as the IPDM is not doing anything it thinks important when it receives the command, it will stop transmitting on the CAN bus and enter low power consumption control mode. The IPDM will wake up when the BCM sends a wake signal, or the ignition switch is turned on, or the IPDM receives an output request from another control unit.

Avoiding a Dead Battery

How often have you seen a car towed in with a discharged battery, only to find that the map light or headlights light up as soon as the charger is connected? To err is human, and Nissan engineers recognized this and created a feature called Battery Saver, which will cut power to the headlights and map

lights a while after the ignition switch is turned off. If the driver forgets to turn off the map light, no big deal; the BCM will cut power and the battery will be safe. A few owners may not like this feature for whatever reason. If you encounter one, Battery Saver can be disabled using the CONSULT on many Nissan models.

Diagnosis and Repair

Diagnosing Problems

In older systems, manual voltage testing was usually the best way to find problems. For instance, if a cooling fan did not come on at 205° F, we would probably start by checking power across the fan motor. If no power was reaching the fan, we might check for power into and out of the relay. If the relay was not switching the power, we might check power across the relay coil. If the relay had power but was not being grounded, we might check the coolant temperature switch.

Most of this is still valid, but relay control has changed. A coolant temperature sensor is now reporting to a control unit instead of to a switch directly grounding a relay. One control unit is making the decision to turn on the fan then telling another to do it in an incomprehensible language of 0s and 1s. Manual voltage testing will not reveal what the control units are seeing, thinking, or saying. Therefore, the data list on the CONSULT may be the best place to start diagnosis. It's quick and easy to see what the control units are seeing, and find out what the control units are trying to do. With that information, you can perform intelligent pinpoint testing. With the CONSULT, you'll also be able to use active tests to determine whether control units are capable of carrying out a command even when there is an input problem that prevents this from happening.

Replacing the BCM

A new BCM must be configured to work with the vehicle in which it's installed. Different trim levels have different features, and if the BCM configuration and vehicle's configuration are mismatched, problems will ensue. Assuming the BCM is still alive and talking, use the CONSULT's "Before Replace ECU" utility in "Re/

Programming, Configuration" to store both the vehicle configuration and any user customized functions. Once the new BCM is installed, use the "Select Saved Data List" function to transfer the information copied during the "Before Replace ECU" procedure. If the BCM is completely dead and won't talk to the CONSULT, install the new BCM then use the "After Replace ECU" procedure to manually input the vehicle's configuration. Don't guess at the configuration! Check the configuration list in the service manual because there may be some tips on how to determine the correct parameters, then inspect the vehicle to determine its configuration. If in doubt about how to determine if a feature is installed, the owner's manual is also a useful resource. You can find both the service manual and the owner's manual at www.nissan-techinfo.com.

Tooling Up

As always, Nissan has some of the best "without factory scan tool" diagnostic instructions in the industry, so it's sometimes possible to muddle through without a CONSULT. However, if you repair Nissan vehicles regularly, a CONSULT will pay for itself in time saved and lead to better diagnostic accuracy. Generic OBDII scanners won't talk to the BCM or IPDM, leaving the technician to manually measure then study inputs and outputs while guessing what's going on inside the black boxes. There are no barriers to purchasing a CONSULT scan tool, so if you want to up your diagnostic game, you can purchase a CONSULT at www.nissanconsult.service-solutions.com.

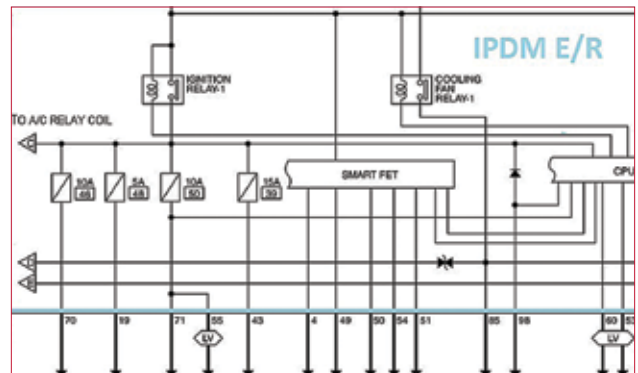

Smart FET diagram.



Innovation that excites

Genuine Nissan Parts. Just a Click Away.



Ordering OE parts is just a click away with the Nissan eSTORE. Genuine Nissan OE replacement parts always deliver model-specific engineering, perfect fit and like-new performance. And now, with our new Wholesale Accounts portal it's even easier to order.

Trust the Original. Genuine Nissan Parts.

parts.NissanUSA.com

When you are unsure how to fix it, call the Nissan Installer Repair Hotline powered by Identifix: 1.855.828.4018

Ordering Made Easy

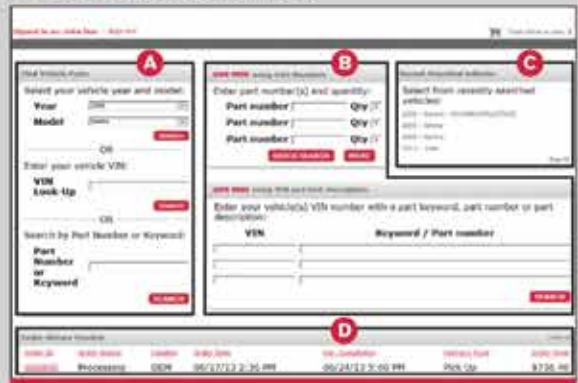

- A** Order by Make, Model, Year, or VIN, or Part Type.
- B** Quick Order if you know the Part Numbers or VIN.
- C** See recently searched vehicles.
- D** Check order status.

Confirm Parts Selection. Fast.

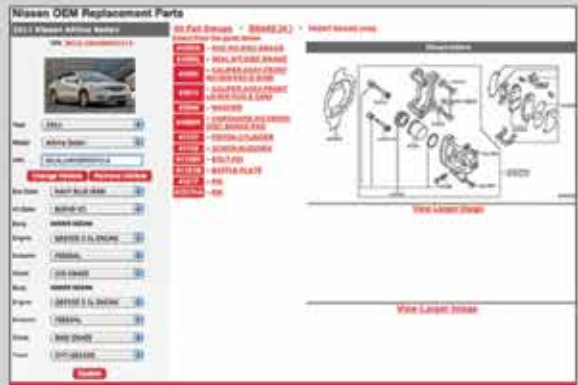

- Parts diagrams and VIN-verified part numbers for every vehicle system and sub-system.
- Current parts availability shown.

New Streamlined Check Out Process

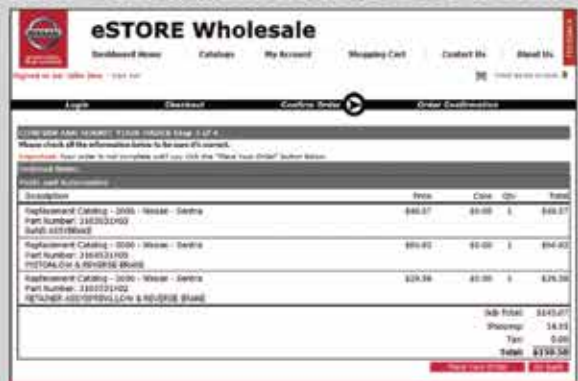

- Your pricing and discounts are readily visible.
- Purchase and delivery preferences are always saved for your next order.
- Make payments or set up billing quickly and easily.

Feature

A Turn for the Better: Nissan Electronic Power Steering

PS

F





Electronic Power Steering (EPS) is becoming common on Nissan vehicles. Here's some technical information and help for when the PS light comes on.



More Nissan vehicles are coming equipped with electronically assisted power steering than ever before, and the trend will almost certainly continue. Electronic power steering is superior to belt-driven hydraulic power steering in almost every way. A large portion of Nissan's lineup is already equipped with some type of EPS. The Cube, JUKE, LEAF and Rogue have a direct drive electric motor (EPS). The Altima and Quest have an electro-hydraulic system (H-EPS).

The greatest advantage of EPS is improved fuel economy over a belt-driven system. A belt-driven pump system maintains pressure any time the engine is running. This means the engine is burning fuel to operate the power steering pump all the time, even when driving straight down the road and no assist is necessary. An EPS system will only draw power when needed to provide steering assist. This saves fuel.

EPS systems are also typically lighter than traditional hydraulic systems and the less the car weighs, the better it is for both fuel economy and performance.

Another advantage is that an EPS system can tailor the assist to match the driver's needs. When driving on the freeway, very little steering effort is needed, but when parallel parking, a lot of assist is needed. A conventional belt-driven hydraulic pump will spin slower when parking and faster on the freeway; the exact opposite of what would be desirable. An EPS system is not tied to engine RPM in any way, and torque or pressure can be easily regulated to match need for a better driving experience.

Finally, there are fewer moving parts and less maintenance involved with EPS systems, compared to conventional hydraulic systems, especially with the direct drive systems. Belt-driven hydraulic pumps work hard all the time, and will eventually fail due to vane wear, bearing wear, seal wear, etc. Metal flake lost from the pump can find its way into control valves in the rack and between the rack gear and bushings, leading to premature rack failure. Hydraulic lines going to an engine-

mounted pump will flex with every acceleration and deceleration, eventually fatiguing and leaking. EPS systems have none of these issues.

Nissan uses two varieties of EPS: a pure EPS system that uses an electric motor to directly drive the steering column or pinion gear. This system is called EPS, and is most often found on lighter cars. Nissan also has an electro-hydraulic system that uses an electric motor to power a hydraulic pump that provides pressure for a traditional hydraulic power steering system. This is called H-EPS and is usually found on mid-sized vehicles.

H-EPS

Other than the electric motor-driven power steering pump and its speed control system, H-EPS is very much like a conventional power steering system. The power steering pump generates the pressure for assist and valving in the power steering rack controls the flow of the pressurized fluid to assist with steering to the right or left. The advantage of H-EPS over belt-driven power steering is the ability to control the pump speed to meet the need for assist.

The pump speed is controlled by the power steering control module, which is typically located with the H-EPS motor/pump assembly. The power

steering control unit is connected to the CAN communication network, and receives inputs from the steering angle sensor, the ECM, and the combination meter via the CAN bus. The steering angle sensor lets the control unit know the rate of change in steering wheel position. The ECM lets the control unit know the engine status. The combination meter lets the control unit know the vehicle speed. Which control unit provides which input may vary a bit model to model, but you'll likely see the same inputs on all models. The H-EPS system does not need a torque sensor because the amount of assist is controlled by the valving in the power steering rack.

The vehicle speed and steering angle sensor inputs control the pump speed and pressure. The pump speed increases when the vehicle speed is low or the steering angle speed is high because more assist is needed when the vehicle is moving at low speeds and when the driver is turning the steering wheel quickly. Likewise, when the vehicle speed is high and the rate of steering angle change is low, the pump speed and pressure will drop to save power and fuel.

The H-EPS system is better suited to larger cars because the reduction ratio is greater than can be achieved through gear reduction on pure



An EPS motor is often mounted directly to the power steering rack, but it can also be mounted to the steering column.

EPS units. This means the size and weight of the system is less than it would need to be for a pure EPS system.

EPS

A pure EPS system needs no hydraulic fluid, lines, pump, or valving. The steering assist is provided directly by a motor. The electric motor can be mounted to either the power steering rack or the steering column. Mounting to the rack provides the advantage of not subjecting the flex joint between the column and pinion gear to high torque. Because the reduction ratio is smaller, the motor RPM is much lower.

The sensor input to the EPS control unit is a little different for this system. Instead of monitoring rate of steering angle change, the EPS control unit monitors a torque sensor which can be mounted on either the steering column or inside the power steering rack on the pinion shaft. The torque sensor input and vehicle speed input are used by the EPS control unit to calculate the optimal level of power assist.

Because low RPM, high torque electric motors can overheat and be damaged, a protection circuit is built into the system. Often, the temperature sensor is mounted in the EPS control unit instead of the motor, so the motor temperature is inferred rather than directly measured. If motor temperatures become too high, the EPS control unit will lower or completely eliminate the output to the motor. This will not

typically happen during normal driving, but the motor can be made to heat up by holding the steering at full lock, or working the steering wheel back and forth while stationary. Once the motor cools, normal operation will be restored.

If you suspect the protection circuit is active, you can check using the CONSULT. In the data monitor there is a PID called "ASSIST LEVEL." This PID will normally read "100%", but will decrease as output to the EPS motor is limited.

EPS Warning Light

The EPS warning light will illuminate for any of the following reasons:

- The EPS is in failsafe mode (no assist) due to motor overheating.
- A control unit has detected a fault with the EPS system.
- The combination unit is performing a bulb check because the ignition is in the ON position (not running).

Failsafe Mode

In failsafe mode, steering will be more difficult, especially at lower speeds. Failsafe mode can be caused by motor overheating or an EPS system fault. Nissan EPS and H-EPS are not control-by-wire systems. There is always a direct mechanical connection between the steering wheel and the front wheels. The worst that can happen is a loss of assist, not a loss of steering.

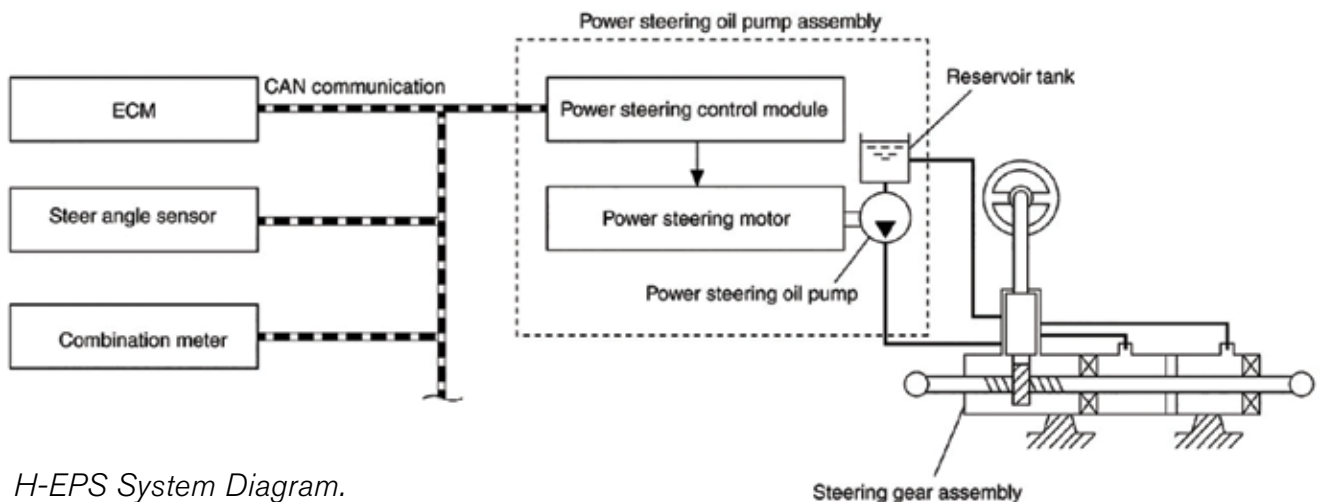

H-EPS System Diagram.

Diagnosing EPS Problems

Nissan's EPS system is more reliable on the whole, so failures are less likely. However, any system can be damaged by external factors such as a collision or improper repair procedures. Let's start by looking at problems that can be inflicted upon the system. If a wheel is hit hard enough to blow a tire, bend a rim, or tweak a tie rod end, it's a good idea to check the EPS rack for damage. If the rack gear is bent it will cause excessive steering effort and sometimes the power steering rack will be overlooked during collision repair. If a customer complains that it's difficult to steer and you find no codes, lift the car and check for binding by sweeping a wheel side to side by hand. If it feels stiffer than normal, disconnect the outer tie rod ends from the knuckles. If there is no binding in the ball joints or strut top mounts, check the pinion rotating torque to see if it is within specification. There is typically no pinion to rack preload adjustment on EPS racks, so if you find pinion rotating torque is higher than specification, replace the rack.

Some models also require a torque sensor calibration after repairs or if the torque sensor reading has drifted. The torque sensor may be located in the steering column or the EPS rack. If the unit containing the torque sensor or the EPS control unit has been replaced, and the torque sensor calibration has not been performed, a C1613 trouble code may set. A C1613 is not an indication of a fault; it's only an indication the

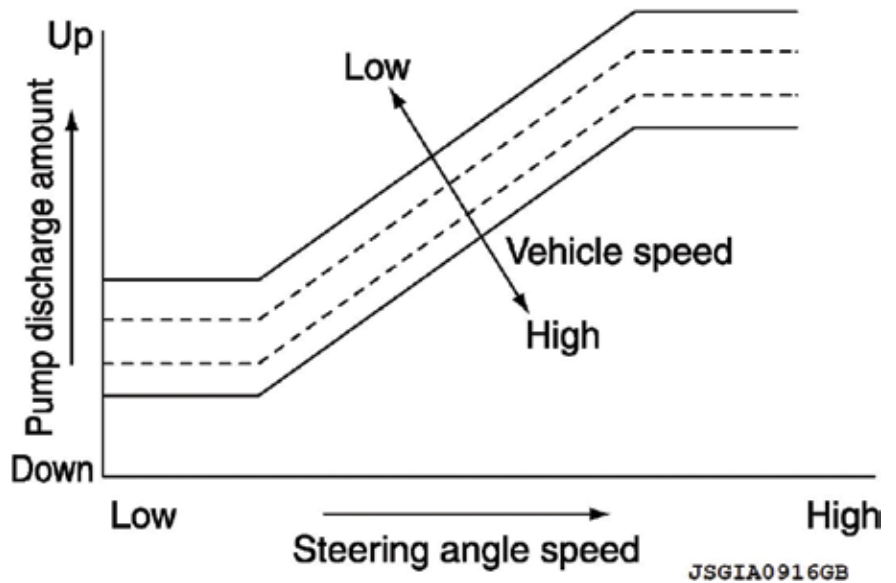

Steering Angle Sensor/Speed graph.

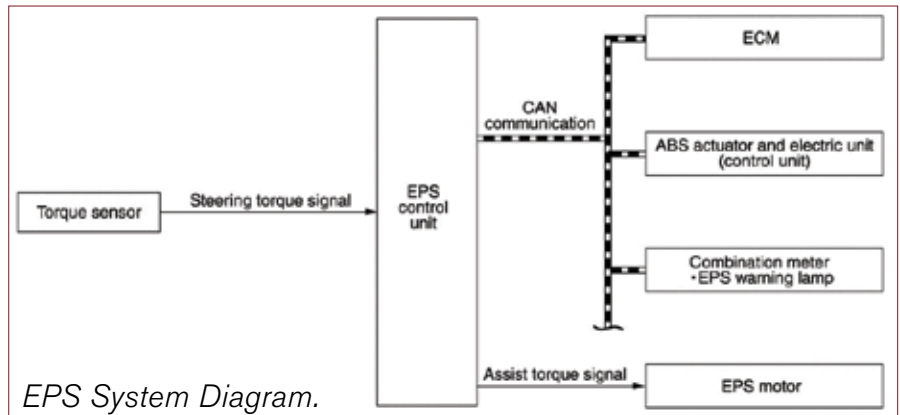

EPS System Diagram.

calibration must be performed before the EPS system will operate properly. If the torque sensor value has drifted, you probably won't find a fault code. However, you will probably notice that steering in one direction is easier than the other. Also, if you check the EPS data list, you'll find that the torque sensor value is not "0" when the steering wheel is at rest. The torque sensors on some other models self-calibrate so no calibration is necessary. The only way to perform a torque sensor calibration is with a CONSULT.

The steering angle sensor is another sensor that may require calibration. On H-EPS systems, the

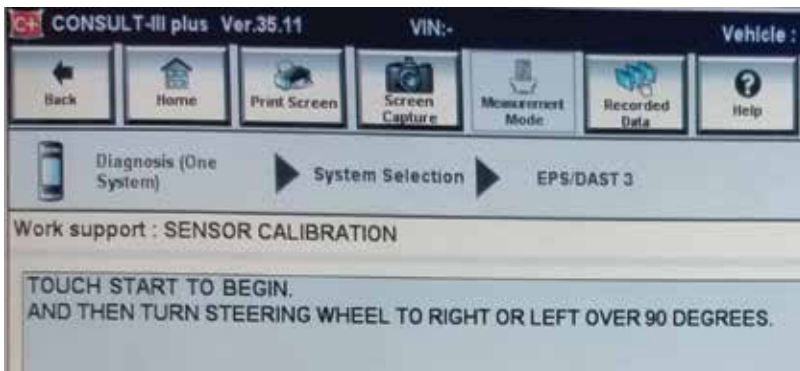

Sensor Calibration.



Diagnosing EPS systems.

steering angle sensor (SAS) is an important input for determining desired EPS pump speed. On EPS systems, the SAS is primarily for the traction control system; the torque sensor is the primary input for the steering system. Regardless, the SAS will be located in either the column or the rack, so when replacing steering components, you may need to perform a calibration. However, you'll likely find the EPS ECU receives SAS data via the CAN bus. The SAS may exist as its own node on the bus, or it may report to the ABS/VDC ECU. You'll need to check the service manual to find out which unit has the SAS calibration utility for the car you're repairing.

Self-Diagnostic Capabilities

The EPS and H-EPS systems will offer some diagnostic help if things go wrong. The available

self-diagnosis and trouble codes will vary from model to model.

C1143 – Steering angle sensor.

This code will likely appear in the EPS ECU on vehicles with the H-EPS system. On vehicles with pure EPS, this code will likely set in a different ECU.

C1601 – Battery power supply.

This code most often sets because the 12V battery becomes discharged while the vehicle is sitting with the key in the ON position, but it can also set

if the alternator or DC/DC converter fails, or if the power supply to the EPS ECU is too low (< 8.5V) or too high (> 18.5V) for any reason.

C1604 – Torque sensor. This code will only occur on EPS systems, not H-EPS systems

C1606 – EPS motor. This code will set on both EPS and H-EPS systems. On H-EPS systems it refers to the pump motor. On EPS it refers to the drive motor.

C1607 & C1608 – Both of these codes indicate internal EPS ECU faults. If they reset after being cleared, the EPS ECU needs to be replaced.

C1609 – Vehicle speed sensor. Only some models will set this code. Others will only set a P0500 code.

C160A – Overheat protection. Only some models will set this code, even though all models will limit torque to prevent overheating. This code does not indicate a fault, it just indicates the temperature protection was activated. This code can be handy if a customer complains his power steering stopped working for a while, because it allows you to confirm that overheat protection was likely the cause.

U1000 – CAN communication circuit. This code will set if the EPS ECU can't receive or transmit on the CAN bus for a period of time, usually around 2 seconds.

Always check the proper service manual or visit the Nissan Tech Info site at www.nissan-tech-info.com for the correct information for the model and year of the vehicle you are servicing. |

Matte Finish and Carbon Fiber – Oh My!

NISSAN

Nissan's 2015 GT-R NISMO is a 600-horsepower, twin turbocharged feast for the senses. The low-gloss matte exterior and carbon fiber bumper fascia and accent body panels are a challenge for collision repair specialists, unless, of course, you pay attention to the step-by-step refinish instructions from Nissan and the manufacturers of the approved matte paint systems.





Since the mid-1980s, Nissan NISMO cars have torn up the tracks at the All Japan Sports Prototype Championship (JSPC), Japanese Touring Car Championship (JTTC), Formula Nippon, 24 Hours of Le Mans and 24 Hours of Daytona. In recent years NISMO cars have participated in the Super GT and FIA GT Championship, and in 2015 will compete at Le Mans with an all-new 3.0-liter, twin turbo, front-wheel-drive V6.

Their track record keeps NISMO cars in the top tier of supercar racing globally. The name NISMO comes from the first two syllables of the Nissan Motorsport division

of parent Nissan Motor Company. The technology spin-off to Nissan's consumer vehicles makes the 2015 GT-R NISMO a street-legal feast for the senses. The 600-horsepower, 3.8-liter, twin-turbocharged V6 with NISMO-tuned suspension, dual-clutch 6-speed transmission, and electronically-controlled all-wheel drive provide massive power, intelligently engineered for performance and confident control.

The 2015 GT-R NISMO is available in a low-gloss matte gray exterior paint finish that shimmers softly rather than shines. The understated elegance of the



matte finish may make drivers feel they should wait for the paparazzi to arrive so they can be photographed making their grand exit from the vehicle.

The GT-R NISMO also features extensive use of carbon fiber from front to rear. Carbon fiber is five times as strong as steel, offers twice the stiffness, and yet weighs two-thirds less. Long used to build super strong yet lightweight bodies and safety cages for Formula One racecars, carbon fiber is now showing up on street machines to help meet fuel economy and emissions targets.

The GT-R NISMO boasts carbon fiber front and rear bumper fascia, rear trunk lid and side sills. There is also a lightweight carbon fiber rear spoiler that increases downforce by 220 pounds for road-hugging high speed performance.

The carbon fiber accents and matte finish offer all of the appeal of the newest clothing from a hot Italian fashion design studio, so you can expect the GT-R NISMO to eventually show up in your collision shop. Here are a few things you'll need to know when it does.

The carbon fiber accents and matte finish may inspire oohs and ahhs, but they also require that



The front bumper fascia and front part of the engine undercover on the 2015 GT-R NISMO are carbon fiber. Combined with the carbon fiber center mud guard, trunk lid, spoiler, and rear bumper fascia, these components not only look striking, they help reduce the total vehicle weight compared to steel.

collision technicians plan repairs and handle color and gloss matching using different procedures than those of the typical metal repair and clear coat refinish job.

Surface Texture and Reflected Light

Traditional clear coats are smooth and even, allowing light to bounce off of the surface in an equal and opposite angle from the source. When every ray of light from a source bounces off of a reflective surface at an equal angle, the surface appears bright and shiny due to the large amount of light being pushed in the same direction. The equal angle also allows an accurate reproduction of the image of the source on the first thing it meets – a wall, your eye, other surfaces. This is how we see our face reflected in a mirror, or in the shiny surface of a new car.

The surface of a matte topcoat is rough and uneven compared to that of a typical gloss clear coat. Microscopic pits and bumps in the surface

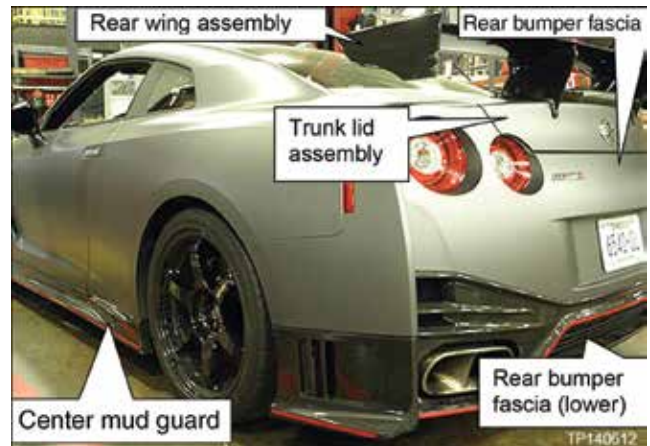

Almost the entire rear end of the 2015 GT-R NISMO is carbon fiber, including the spoiler, trunk lid, rear bumper fascia (on which the license plate mounts), and the lower bumper fascia. You can see (and feel) the carbon fiber texture in the surface of the wraparound dark lower bumper fascia. The light components (trunk lid, rear bumper fascia) receive primer, a color base coat and a standard clear. The color is part of the carbon fiber material in the dark components (spoiler, lower bumper fascia), so they receive only clear coat.

scatter light randomly, which significantly reduces the brightness and shine of the surface, and causes any reflections to appear weak or blurry.

No Buffing!

Any errors in application of the matte clear coat cannot be buffed out. Buffing or polishing flattens the topcoat pits and bumps, resulting in significant differences in sheen compared to non-polished

areas. Dirt in the application of the clear coat, mottling or striping due to improper spray technique, variations in film thickness and other visible defects require complete repainting of the final topcoat.

To minimize the need for buffing out imperfections, clean the vehicle before beginning to paint, and check for dust and other contaminants after applying the primer and basecoat layers. Also, use

spray-out test cards to check for color and gloss match before painting the vehicle.

Experience Counts

The factory Gray Metallic matte finish on the GT-R NIMO consists of two top layers – a normal color base coat (color code: KAD) and a low gloss matte clear coat (color code: KBL). If you've had good experience with pearlized, metallic, and other premium automotive paints, you already have the skills to mix and apply matte paints properly, and to match color and gloss level.

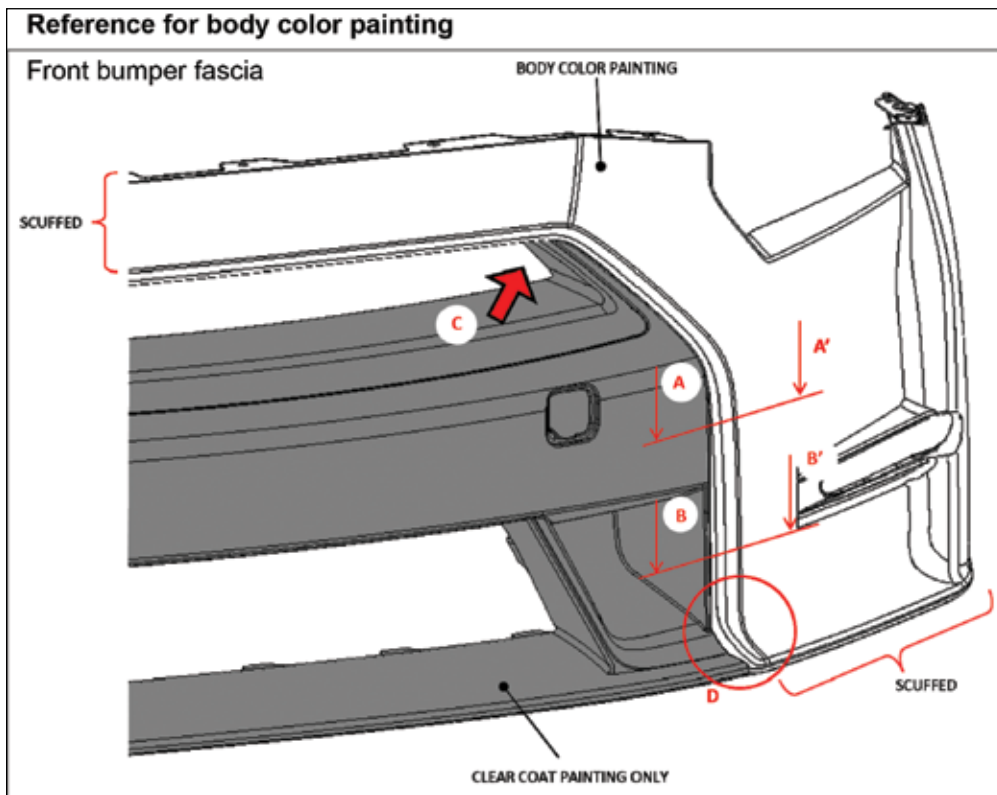

Refer to Nissan technical information for instructions on application of a scuffing treatment to the front bumper fascia.

Approved Paint Manufacturers

| SUPPLIER | BRAND | SOLVENT BASE | WATER BASE |
|--------------------|--------------------------------------|--------------|------------|
| BASF | Glasurit / RM® | Available | Available |
| PPG | (1) | Available | Available |
| AKZO Nobel | Sikkens | Available | Available |
| Sherwin Williams | (1) | Available | Available |
| Axalta (ex DuPont) | Standex® Spies Hecker® Cromax® | Available | Available |
| Kansai Paint | RETAN PG ECO | Available | Available |
| Nippon Paint | (1) | Available | (1) |

(1) Contact manufacturer for the brand name of the product that will work with the GT-R paint system for your region.

The Art of the Mix

Regular gloss paint reflects approximately 90% of light, while matte finishes reflect only 20% of the light that hits them. The low reflectivity is a result of the use of different hardeners, reducers, application methods and drying options.

It is important to use Nissan-approved paints and follow the paint manufacturer's recommended mixing formulas and application procedures. Minor deviations from the recommended ratio of hardener and reducer to the clear coat paint itself will result in significant changes in the gloss level.

Of course, sometimes matching the color of the base coat and gloss level of the clear to those of the vehicle may necessitate mixture or application process revisions. For example, the ambient temperature in your shop can affect your choice of whether to use slow or fast-acting hardeners and reducers, a relatively dry or wet spray technique, the length of flash-off time, and other factors that impact gloss level. Different combinations of these factors can alter gloss level by up to 20%.

Additionally, film buildup due to painting over the original factory clear coat can cause a color shift,

or the gloss level of the vehicle may have changed due to its age and cleaning frequency. This may necessitate painting the entire side of the vehicle instead of just the damaged panel, in order to match the gloss level on that side.

When properly mixed and applied, the finish provides the same protection against stone chipping, corrosion, bird droppings, tree sap and other contaminants as non-matte coatings.

Test and Test Again

There are so many factors that can affect your ability to match the vehicle that you must create spray-out test cards before applying both the color and gloss coat. After looking up the color formula recommended by the matte paint manufacturer, spray at least three test cards with different ratios of matting agent (flattener) and clear coat. Colors will appear significantly darker when dry, so after drying, compare each test card to the vehicle. Evaluate both the color and gloss level. Check in natural daylight. Hold the card against the vehicle surface to ensure that your viewing angle and light source are the same for the area being repaired.

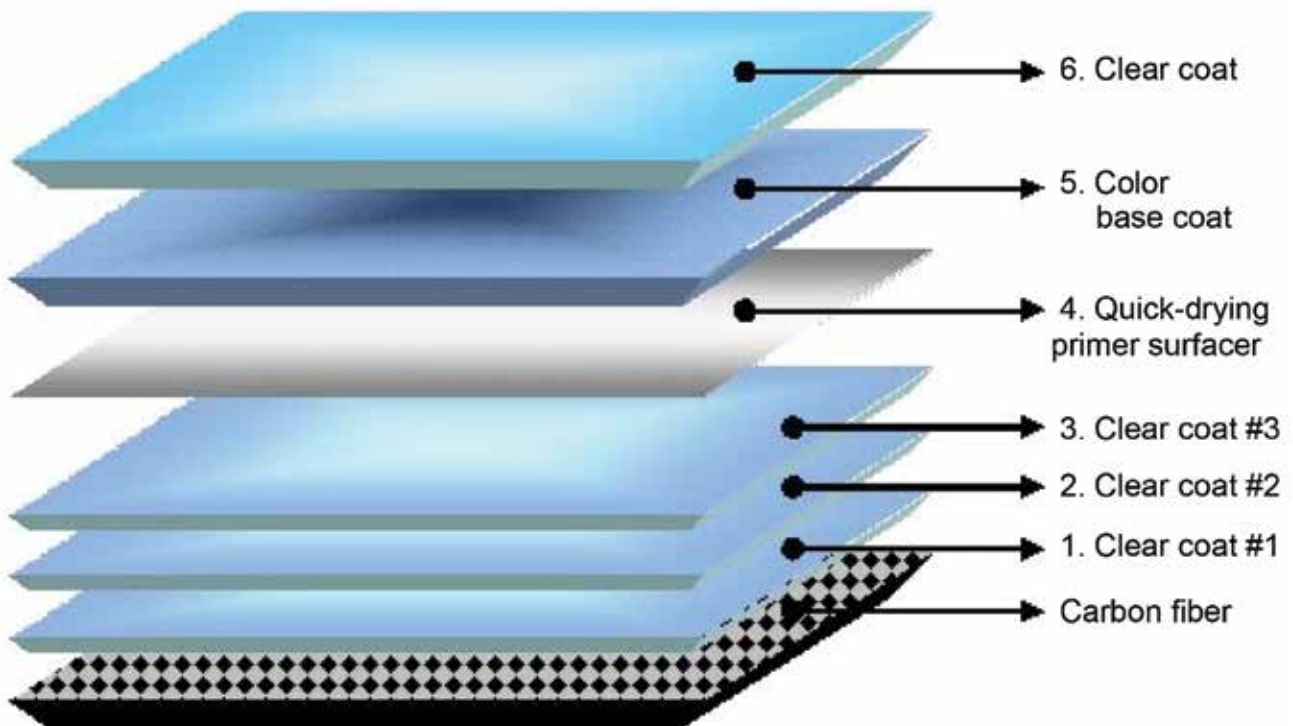

The light-colored body panels (trunk lid and front and rear bumper fascia) receive layers 4, 5 and 6 in the coating steps diagram, while the darker components receive only the clear (steps 1, 2 and 3).



Innovation
that excites

OUR COOLEST IDEA YET.



Optimal tube and fin configuration provides ideal coolant flow and efficient heat transfer.

CV oil coolers included where required.



All standard fittings included.

INTRODUCING NISSAN VALUE ADVANTAGE™ RADIATORS

Radiators are a common replacement in front-end collisions. Your customers deserve a product that meets Nissan OE standards for fit, form and function. Value Advantage–Nissan validated performance at very competitive prices, average list price just \$204*.



Help is here—call the Nissan Installer Repair Hotline. 1.855.828.4018



VIN specific online ordering—parts.NissanUSA.com

Trust the Original. Genuine Nissan Parts.

parts.NissanUSA.com

*actual prices set by individual dealers.

Spray Expert

“Mottled” describes a finish that is streaked, spotty, or striped. It is the result of an unbalanced spray pattern, or of not observing the proper flash time between base coat and clear coat. If one spray pass is heavier than the others, that area may appear glossier after curing. Try to spray so that you maintain a wet edge, but no one pass is heavier than the others.

Changing the angle of the spray gun between strokes can result in uneven film thickness and stripes in the work. For example, if you paint while too tired, you may inadvertently allow your arm to drop while spraying. This tilts the spray up, resulting in more paint placed on the bottom portion of the pass than the top, and bingo, you’ve created a horizontal stripe in your finish.

Experiment with overlap. If a 50% overlap leaves light streaks, try 75%. Just be sure to maintain consistency with each pass.

To further reduce the appearance of striping, spray in different directions in the same coat. After covering the panel with horizontal passes, cover again while the coat is still wet, but use vertical strokes.

Two Different Coating Treatments for Carbon Fiber

The trunk lid and front and rear bumper fascia each receive only three coating layers – a primer, color base coat, and a standard clear coat. The engine undercover (front part), center mud guard, rear bumper fascia (lower part) and rear wing assembly (spoiler) get clear coat (three layers) and no primer or color coats, as the color is already built into the carbon fiber material.

If any damage exposes the actual carbon fiber, do not attempt to repair that part. The quality and adhesion of the coatings on any component with exposed carbon fibers cannot be guaranteed. Replace that part.

There are special steps required to “scuff” the front and rear bumper fascia and the outer side of the trunk lid. Refer to www.nissan-techinfo.com for further details. |

Cleaning the Matte Finish

Damage that results from failure to follow proper matte paint care instructions is not covered under Nissan’s new vehicle warranty. Matte finish care differences include:

Preparation

- Remove road tar, insect or bird droppings, tree sap or other contaminants immediately. Do not use solvent-based tar and bug remover.
- Pre-rinse the vehicle to remove coarse dirt that could scratch the paint. Pre-clean or treat heavily soiled areas before washing the entire vehicle.
- Use only cleaners that are specially formulated for matte paint. If not available, use mild soap. Do not use solvent-based products such as wax and grease remover.

Washing the Matte Paint

- Wash by hand, not with pressure washer or automatic car wash.
- Use buckets with dirt separator grids (available at auto parts stores). Use two separate buckets, one for washing with soap, and the other for rinsing with clean water.
- Hand wash with a wet microfiber cloth (no terry cloth towels for washing or drying). After each application of soap to the vehicle, rinse the microfiber cloth in the clean water before putting the cloth back into the soapy water.
- Dry with a clean, damp chamois. Use only light pressure with chamois or microfiber towels, to minimize the risk of creating high-shine spots. If surfaces begin to air-dry, re-dampen them and use the clean, dry chamois to dry the area. Do not allow surfaces to air dry, as this will leave water spots.
- Do not use waxes and sealers, even those specifically formulated for matte paint. These products may add an undesirable shiny appearance to the matte finish.

Cleaning the Wheels

- Use a product specifically for cleaning the wheels. Do not get any wheel cleaner on body panels or other painted areas. Immediately wash and rinse the paint if any wheel cleaner gets on the paint.



Innovation
that excites

Value Advantage™: High Performance. High Value.

- Build trust; offer customers both Nissan OE and Value Advantage™ parts.
- Quality products validated by Nissan Engineers.
- Save 35% off MSRP* on eligible parts categories.

Everyday Low Pricing on Nissan's Most Popular Parts Categories!

- Air/Oil Filters
- Brake Pads
- Rotors
- Belts/Hoses
- Shocks/Struts
- Wiper Blades
- Spark Plugs
- Radiators & Caps
- Thermostats
- Wheel Bearings
- Cabin Filters
- All Value Advantage™ Parts



Help is Here.

When you are unsure how to fix it, call the complimentary Nissan Installer Repair Hotline powered by Identifix: 1.855.828.4018.

Trust The Original. Genuine Nissan Parts.

*Certain restrictions apply. See participating dealer for details. 35% off MSRP for eligible popular parts only. MSRP excludes all applicable taxes. Participating dealer sets actual price. Nissan, the Nissan Brand Symbol, "Innovation that excites" tagline and Nissan model names are Nissan trademarks. ©2015 Nissan North America, Inc.



**Innovation
that excites**

VALUE ADVANTAGE™ ROTORS – THE RIGHT PART FOR THE JOB

For newer vehicles and for customers who insist on using parts engineered for their exact vehicle, it's always recommended to use the original equipment (OE) part. OE parts from Nissan meet all Federal Motor Vehicle Safety Standards (FMVSS) to deliver optimal performance for each specific application. But for customers with older vehicles, or for customers who are very price conscious, an OE part may prove too costly. Fortunately, there is a high-quality solution.

Nissan's new high-quality line of brake parts can help retain this customer base and keep them from migrating to independent repair shops. Nissan Value Advantage brake parts can help increase retention, win customers back from the independent repair shops and increase profits at the dealership.

TIGHT LATERAL RUNOUT

Rotor runout should be checked on the vehicle and not the brake lathe, as the rotor may run true on the lathe, but not the vehicle. A runout of .005" can result in pedal pulsation or brake noise, and many competitive Aftermarket rotors exceed .005". Nissan Value Advantage brake rotors are ready to install out of the box with no turning required because they have a lateral runout of .004" or less. Excessive runout can cause friction material transfer after 5,000–7,000 miles, which can adversely affect pulsation.

PROPER BALANCE

Excessive vibration in rotating rotors can cause unacceptable levels of noise and reduce the life of the rotor. 100% validation ensures proper balance and minimizes vibration. Nissan Value Advantage brake rotors meet OE requirements and are mill balanced to 2 inch-ounces. Many competitive Aftermarket rotors can exceed 5 inch-ounces.

MINIMAL THICKNESS VARIATION

Brake pads must contact the rotor flatly during braking to avoid pedal pulsation. As little as 0.0005 inches of thickness variation can result in pedal pulsation and noise. Nissan Value Advantage brake rotors have a thickness variation of 0.0004 inches or less ... helping the rotor turn as true as possible inside the caliper, resulting in fewer pulsation issues.



©2015 Nissan North America, Inc.

Nissan, the Nissan Brand Symbol, "Innovation that excites" tagline, Nissan model names and Value Advantage are Nissan trademarks.

VALUE ADVANTAGE™

