

TechConnect

V7 | N2 | Spring 2015

\$7.95 USD



Das Auto.



2.0 TSI Timing Belt

Incluyendo Traducción Especial al Español



Throttle-by-Wire
A/C System Lubricant
Parts Warranty

Your source for Genuine Volkswagen repair information.



Great for the price of good.

Volkswagen Economy Batteries.
How convenient.

- A smart choice for vehicles five years old and older
- Provides budget-conscious customers with a “Genuine” alternative
- Volkswagen functionality and safety
- Proper scale and fitment



Install value.

Contact your local dealer today for a full line of VW Economy Batteries.

MSRP \$113.00*

Image is for illustrative purposes only. Actual battery may vary.

*Price shown is the manufacturer suggested retail price. Dealer sets final price.

"Volkswagen," "Das Auto," and the Volkswagen logo are registered trademarks of Volkswagen AG. ©2015 Volkswagen of America, Inc.



TechConnect

V7 | N2 | Spring 2015

Your Source for Genuine Volkswagen Repair Information.



Volkswagen TechConnect is a publication of Volkswagen Group of America, Inc.

Senior Manager Wholesale Parts Operations

Scott Barone
Scott.Barone@vw.com

Volkswagen Wholesale Parts Team

Alex Malyshev
Ashley Biggs

Volkswagen Technical Review Team

Jay Bartling
Technical Curriculum Designer

Brian Murray
Technical Curriculum Designer

Kurt Immekus
Service Aftermarket Compliance Specialist

Warren Barbee
Collision Repair Technical Instructor

Editorial Director

Bob Freudenberger
bfreud@automotivedatamedia.com

Contributing Writers

Phil Fournier, Wayne Riley,
Glenn Quagmire, Frank Walker

Editorial & Business Offices:

134 B River Rd.
Montague, NJ 07827
Phone: 330.620.3929
www.AutomotiveDataMedia.com

President & Group Publisher

Christopher M. Ayers Jr.
cayers@automotivedatamedia.com

VP, Business Development

Tamra Ayers
tayers@automotivedatamedia.com

VP, Creative Director

Christopher M. Ayers III
ayersc3@automotivedatamedia.com

Caution: Vehicle servicing performed by untrained persons could result in serious injury to those persons or others. Information contained in this publication is intended for use by trained, professional auto repair technicians ONLY. This information is provided to inform these technicians of conditions which may occur in some vehicles or to provide information which could assist them in proper servicing of these vehicles.

Properly trained technicians have the equipment, tools, safety instructions, and know-how to perform repairs correctly and safely. If a condition is described, DO NOT assume that a topic covered in these pages automatically applies to your vehicle or that your vehicle has that condition. For specific warnings pertaining to the servicing of specific Volkswagen systems and features, refer to: <https://www.erwin.volkswagen.de/erwin/showhome.do>.

vwparts.com



14 Volkswagen's Throttle-by-Wire

This state-of-the-art system has been around for a while. You should know how it works. Today's technician also needs to know how this system integrates into the big picture of engine management. Let's also look in to the need for proper connections in this system.



20 A/C System Lubricant

Lubricant issues are the number one cause of air conditioning compressor problems. Not enough, not the correct type, or inferior A/C lubrication are estimated to contribute to as much as one-third of all automotive compressor failures.



26 The Volkswagen Genuine Parts Warranty

Sure, there are some things you could get from the aftermarket, but nothing good happens if they fail.

30 Global Rallycross Brings Red Hot Beetles...

34 CCRF Program and Academy Training Schedule

Replacing the 2.0L TSI/BPY Timing Belt





The VW 2-liter BPY-designated engine was widely used in mid-2000 model year cars, including the Passat, Eos, Jetta, Rabbit, and Rabbit/GTI. It is a well-constructed dual overhead cam gasoline powerplant that can deliver excellent power, economy* and reliability. Like all overhead cam engines in which the camshafts are belt-driven, the timing belt requires routine replacement as part of scheduled maintenance. The BPY engine uses a single camshaft timing belt sprocket to power both camshafts via a connecting chain between the camshafts. This 2.0L is an interference engine, which means that pistons and valves can meet in a most uncomfortable fashion if the timing belt should break. On the BPY engine the belt should be checked at 60,000 miles and replaced if it's questionable. And it should be replaced at 100,000 miles in any event.

There are two belts on these engines, a serpentine accessory drive belt that VW refers to as a ribbed belt (for obvious reasons...) and a toothed belt, which is the timing belt that keeps the camshafts and valves in happy coordination.

The earliest configurations of this engine family used a one-piece belt guard for the toothed timing belt, and this design requires a bit more work than the later design, introduced in 2006, which used a two-piece guard, making access faster and easier. We'll deal with that one first, since it is the more common design, and then we'll come back and recap the additional steps needed when dealing with the single-piece design.

**Based on EPA estimates. See fuelconomy.gov for details. Actual mileage will vary and depends on several factors including driving habits and vehicle condition.*

Start at the Beginning

After removing the engine cover and upper air filter housing, you'll need to disconnect the fuel pump module electrical connector since the fuel pump is initially activated by the driver's door contact switch. Of course, you'll need to exercise the usual cautions about de-pressurizing the fuel and cooling systems, and work on an engine that's at ambient temperature.

All that being said, start by marking and disconnecting the three fuel lines at the fuel rail. This will facilitate proper reassembly. Unbolt the coolant recovery bottle and move it to the side, disconnecting the electrical connector if necessary for improved access. Mark the direction of rotation of the ribbed serpentine belt and remove it by loosening the spring-loaded tensioner with an appropriate tool. Then remove the tensioner itself.

At this point you'll need to support the engine since it will need to be raised off its mounts to gain access to the timing belt. There are several special VW service tools for supporting the engine, and you likely have a shop crane with appropriate adapters for safely supporting the engine.

Remove the two bolts that secure the upper timing belt cover, and lift out the cover, keeping the engine supported for subsequent steps. After removing the adjacent body noise insulation, unbolt and remove the right front wheelhouse liner.

It's Time to Take Your Time

Now the precision work begins. Bring the camshaft gear to the TDC mark for cylinder #1, such that the arrow on the camshaft sprocket aligns with the arrow on the belt gear.

The next step is to remove the vibration damper and its pulley. It is critical at this point, with the engine known to be at TDC, to make an additional mark on the crankshaft to identify TDC, since reference will be lost once the damper and pulley have been removed.

Next, remove the five bolts that secure the lower half of the toothed belt guard and lift off the guard, and remove the lower engine mount bracket bolt, loosen the fasteners for the right main wheelhouse liner, and push it off to the side.

Now you can access the second engine mount bracket bolt through the hole in the wheelhouse, and remove the two pendulum support bolts.

At this point you can remove the two bolts holding the engine mount itself in place, and lift out the mount. After raising the engine, you'll be able to remove the remaining bolt that secures

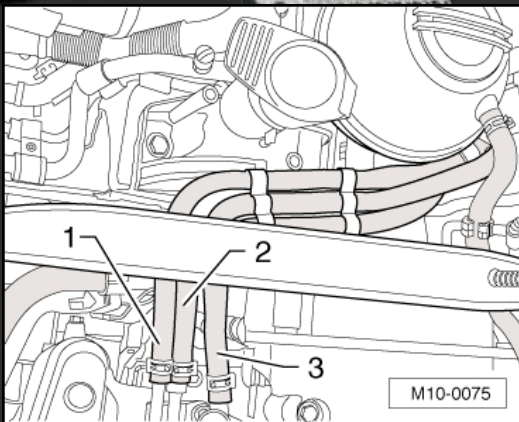

Mark the three fuel line hoses to facilitate reassembly. Be sure to de-pressurize the fuel system first.

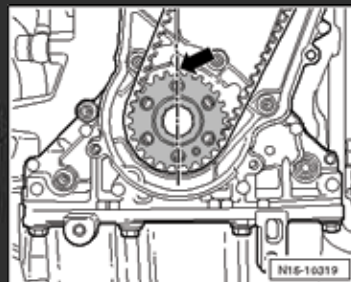

Aligning timing marks to this position puts cylinder #1 at TDC.

the engine mount bracket. Remove the two bolts that secure the lower half of the timing belt cover, remove the cover downward, and lift out the bracket upward.

Now, if you're in there for some reason other than timing belt replacement, you can mark the direction of rotation of the timing belt to facilitate re-installation. But, frankly, unless you know the belt was replaced quite recently, it would be wise to recommend replacement at this time. Next, loosen the roller nut for the semi-automatic tensioner, turn the crankshaft back slightly, and lift the belt out.

At this point you can use this opportunity to offer to replace the water pump. It is pretty labor-intensive to get this far into the engine, and the water pump is now readily accessible. You may find that few customers would object to the modest additional cost of a genuine new VW water pump carrying little additional labor cost. And you should also take advantage of this opportunity to carefully examine both the toothed belt and the ribbed belt for any signs of irregular or uneven wear, which might indicate looseness or misalignment of one of the pulleys or pivot points.

Readying for Reassembly

In preparing the engine for installation of the new timing belt, you'll need to assure that both the crankshaft and camshaft are at TDC. But since this is an interference engine, if you turn the camshaft with the crankshaft at TDC, you risk valves meeting pistons. So, it's better to set the camshaft to TDC first, and then the crankshaft.

With crank and cam both at TDC, install the timing belt in the

following order: crankshaft gear, then the roller for the semi-automatic tensioner, then the camshaft gear, the water pump, and finally around the damper pulley.

In the process, assure that the tensioner roller is firmly seated in the cylinder head.

Setting the tension on the new belt is a critical step. You first need to over-tighten it by turning the eccentric clockwise until the notch is above the tab. Then, loosen the belt and re-tension it until the notch and tab align. Now, tighten the nut on the semi-automatic tensioner roller. For confirmation, rotate the crankshaft two full turns, in the normal direction of rotation, back to TDC, with the last 45 degrees of rotation turned without

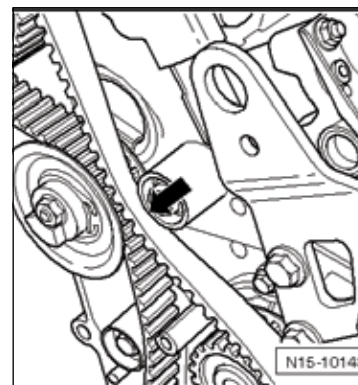

When fitting the new timing belt, observe the proper order of assembly and make the last step routing the belt around the damper pulley.

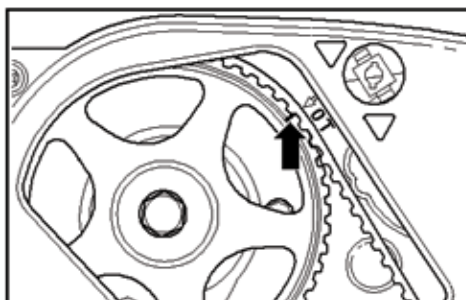

With cylinder #1 at TDC on its compression stroke, the marking on camshaft gear must align with the arrow on the toothed belt guard.

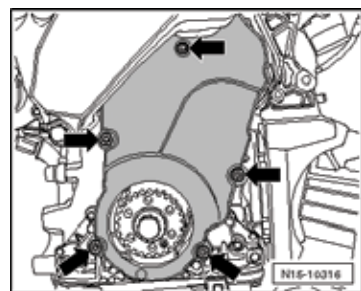
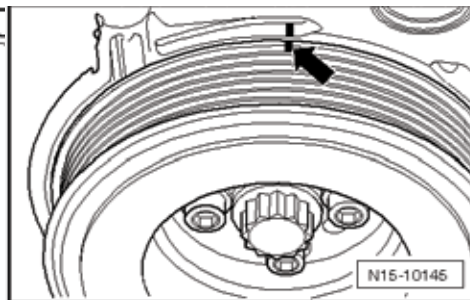

These are the five bolts that hold the lower belt guard in place.

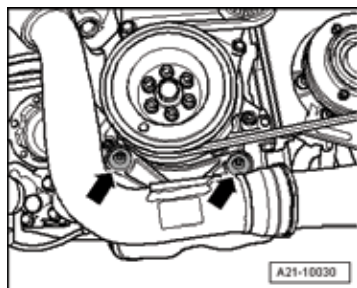

Two bolts hold the charge air cooler pipe in place. You'll need to remove the bolts and the pipe to access the belt.

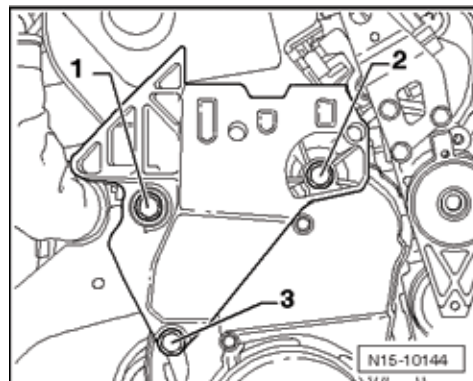

Here are the three bolts that secure the engine mount bracket to the block.

interruption. Check again to assure that the notch and tab still align. This will confirm that the crankshaft and camshaft are properly synchronized. Double-check the valve timing by noting the alignment of the marks on the camshaft sprocket and the housing behind it.

After that, reassembly is pretty much a reversal of the disassembly procedure, with a couple of cautions:

- Reinstall the vibration damper pulley using new bolts.

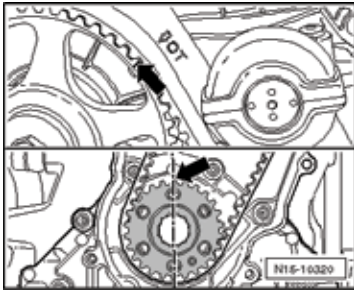

Left: Before installing the new timing belt ensure that the timing marks are aligned so that both the crankshaft and camshaft sprockets are precisely at TDC.

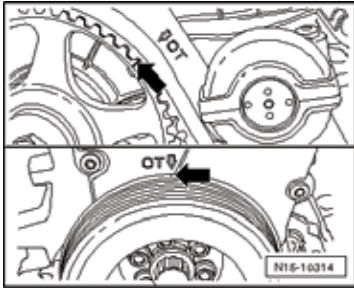

Left: This is how the timing marks should appear if the new belt has been properly tensioned and synchronized.

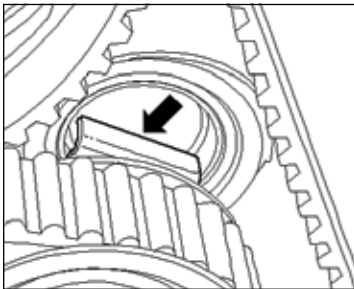

Left: This shows proper assembly of the automatic tensioner roller.

A Kit Does the Trick

Since there are certain parts that should be replaced whenever installing a new timing belt on a VW engine, the good folks at Volkswagen have conveniently packaged appropriate parts into timing belt replacement kits. These kits, available for both gas and diesel applications, typically include a new timing belt, a new tensioner, new relay rollers and, where appropriate, single-use fasteners that should be replaced in the process. While not included in these kits, it is recommended to buy and replace the water pump and accessory drive belt during this service since it is fairly labor-intensive to be this far into the engine, and provides good value to the customer.

A listing of popular applications appears between pages 10 & 11; be sure to check with your VW parts professional for the exact kit for the car you're servicing.

- Triple-check the valve timing marks, assuring that the arrows align.
- Note that the engine mount bracket is secured by two bolts of the same length, and a third bolt that's slightly shorter than the other two. This shorter bolt goes into the bottom-most hole.
- Observe the engine mount alignment procedure to assure proper clearances around engine components.
- Observe proper torque specifications for all fasteners.

BPY torque specifications

Semi automatic tensioner roller nut:	25 Nm
Vibration dampener:	8.8 bolts - 10 Nm + 90° (1/4 turn). Use new bolts.
	10.9 bolts - 20 Nm + 90° (1/4 turn). Use new bolts.
Engine mount bolts (3):	45 Nm. Use new bolts.

For all other fasteners refer to the following table: Fastener Tightening Specifications

Component Fastener Size Bolts and Nuts		
M6 - 10 Nm	M10 - 40 Nm	M7 - 15 Nm
M12 - 60 Nm	M8 - 25 Nm	

Now What About That One-Piece Cover Design?

The procedure for replacing the timing belt on the earlier engine design with the one-piece cover for the timing belt is similar to that on the two-piece design. However, the job is more labor-intensive because the engine must be raised higher in order to access and remove the one-piece cover. For this reason, it is necessary to disconnect both front wheel drive half-shafts from the transmission, and also to remove the front exhaust pipe with the catalytic converter in order to allow for the added lift height needed.

Eliminating these extra steps was the reason for Volkswagen moving to the improved two-piece design in later models, and there are relatively few of the earlier cars with the one-piece cover.

In any event, timing belt replacement is an important procedure that needs to be performed as scheduled in order to prevent major engine damage, the likes of which we've all seen, and the aftermath isn't pretty. Your local Volkswagen dealership parts department can provide you with the quality belt, fasteners, and water pump you'll need for this job, and your customer can motor on, confident that the valves and pistons will happily keep their distance from each other. ●

Reemplazando la Banda (Correa) de Tiempo, Motor 2.0 TSI/BPY





El motor VW de 2 litros, señalado BPY, era ampliamente utilizado en los vehículos de los años 2005 para arriba, incluyendo el Passat, Jetta, Eos, Rabbit y Rabbit/GTI. Es un motor de gasolina de bastante calidad de construcción, doble árbol de levas, que puede ofrecer excelente potencia, *economía y fiabilidad. Como todos los motores de árbol de levas en el cual los árboles de levas son accionados por banda, la banda de tiempo requiere reemplazo rutinario como parte del mantenimiento programado. El motor BPY utiliza una sola rueda dentada de la banda de sincronización para alimentar dos árboles mediante una cadena de conexión entre los dos árboles. Este 2.0L es un motor de interferencia, lo que significa que los pistones y las válvulas pueden pegarse de la manera más incómoda si se rompe la banda de tiempo. En el motor BPY la banda debe ser inspeccionada en los 96,000 kilómetros y reemplazada si queda dudable. En cualquier caso debe reemplazarse a 160,000 kms.

Hay dos bandas en estos motores, una banda (la serpentina) de transmisión de accesorios que VW se refiere a como una banda acanalada (por motivos obvios...) y una banda dentada, que es la banda de sincronización que mantiene los árboles de levas y válvulas en coordinación.

Las configuraciones más tempranas de esta familia de motor utilizan un protector de la banda de una sola pieza, y este diseño requiere un poco más de trabajo que el diseño más reciente, introducido en el 2006, el cual utiliza un protector de dos piezas, con acceso más rápido y más fácil para el servicio. Trataremos con aquél en primer lugar, puesto que es el diseño más común, y entonces volveremos a considerar las medidas adicionales necesarias cuando se trata con el diseño de la pieza única.

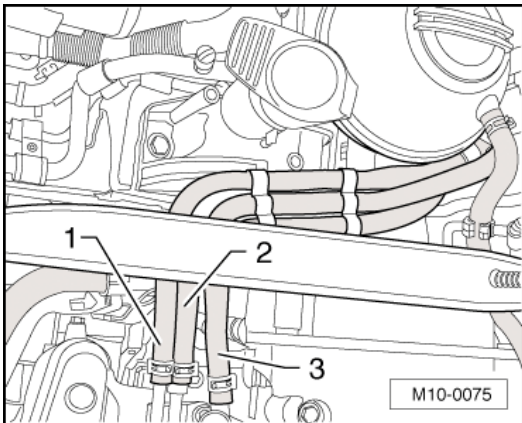

Marque las tres mangueras de las tuberías de combustible para facilitar el montaje. Asegúrese de despresurizar el sistema de combustible primero.

*Basado en las estimaciones de la EPA. Vea www.fueleconomy.gov para más detalles. El kilometraje real puede variar y depende de varios factores incluyendo los hábitos de conducción y estado del vehículo.

Empezar desde el Principio

Después de quitar la cubierta del motor y la caja del filtro de aire superior, tendrá que desconectar el conector eléctrico del módulo de la bomba de combustible, siendo que la bomba de combustible se activa inicialmente a través del interruptor de la puerta del conductor. Por supuesto, tendrá que ejercer las precauciones normales acerca de la despresurización de los sistemas de combustible y de refrigeración, y el trabajo en un motor que ya se ha enfriado.

Continuando, comience marcando y desconectando las tres líneas de combustible en el riel de combustible. Esto facilitará el armado correcto. Destornille la botella de recuperación de refrigerante y muévelo hacia un lado, desconectando el conector eléctrico si es necesario para el acceso mejorado. Marque la dirección de rotación de la banda serpentina acanalada y quítela, soltando el tensor con la herramienta apropiada. Entonces quite el propio tensor.

A este punto tendrá que apoyar el motor ya que tendrá que ser levantado de sus soportes para ganar el acceso a la banda de tiempo. Hay varios instrumentos del servicio VW especiales para apoyar el motor, y probablemente su taller tiene una grúa con adaptadores apropiados para apoyar el motor sin riesgo.

Retire los dos tornillos que fijan la cubierta de la banda de tiempo superior y levante la cubierta, manteniendo el apoyo del motor en los siguientes pasos. Después de quitar el aislamiento de ruido adyacente, desatornille y retire la lámina protectora del guardafango.

iNo hay prisa! Avance con cuidado

Ahora comienza el trabajo de precisión. Trae el engranaje del árbol de levas a la marca TDC para cilindro #1, tal que la flecha sobre la rueda dentada del árbol de levas se alinee con la flecha en el protector de la banda.

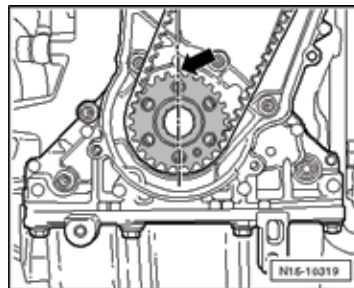

Alineando las marcas de sincronización para esta posición pone el cilindro #1 en el TDC (Punto Muerto Superior.)

El siguiente paso es quitar el balanceador armónico y su polea. En este punto, es crítico con el motor a TDC, realizar una marca adicional para identificar TDC, puesto que la referencia se perderá una vez que se ha quitado el balanceador y la polea del cigüeñal.

A continuación, retire los cinco tornillos que fijan la parte inferior de la protección

de la banda dentada y levantar la guardia y extraer el tornillo del soporte de montaje del motor, afloje las fijaciones para la lámina protectora del guardafango y empújela hacia el lado.

Ahora puede tener acceso al segundo tornillo del soporte de motor a través del agujero en la caja de la rueda y quitar los dos tornillos de apoyo del péndulo.

En este punto, puede retirar los dos tornillos que sujetan al soporte del motor en sí en su lugar, y sacar el soporte. Después de elevar el motor, usted será capaz de extraer el tornillo restante que fija el soporte del montaje del motor. Quitar los dos tornillos que fijan la mitad inferior de la cubierta de la banda de sincronización, extraer la tapa hacia abajo, y levante el soporte hacia arriba.

Ahora, si estás ahí por alguna razón que no sea el reemplazo de la banda de sincronización, puede marcar la dirección de rotación de la banda dentada para facilitar la instalación. Pero, francamente, si no sabe que la banda fue reemplazada hace poco, sería prudente recomendar el reemplazo en este momento... A continuación, afloje la tuerca del rodillo para el tensor semiautomático, gire al cigüeñal un poco y levante la banda hacia fuera.

En este punto se puede utilizar esta oportunidad para recomendar el cambio de la bomba de agua. Es bastante intensiva la mano de obra para llegar hasta aquí en el motor, y la bomba de agua es ahora fácilmente accesible. Usted puede encontrar que pocos clientes se

opondrían al modesto costo adicional de una verdadera bomba de agua nueva VW con poco costo adicional de la mano de obra. También se debe sacar provecho de esta oportunidad para examinar con cuidado la banda dentada y la banda acanalada en busca de señales de desgaste irregular o desparejo, lo que podría indicar si están flojos o desajustada una de las poleas o puntos de pivote.

Listo para Armar

En la preparación del motor para la instalación de la banda dentada nueva, usted necesitará

Para montar la banda de tiempo nueva, observar el orden adecuado de ensamblaje y hacer el último paso de la banda alrededor de la polea del amortiguador.

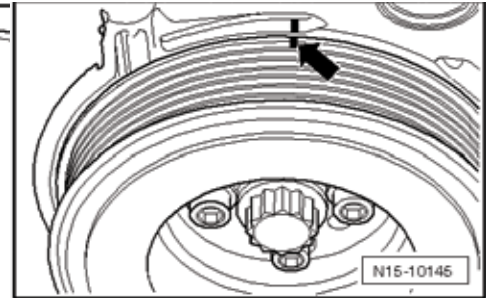
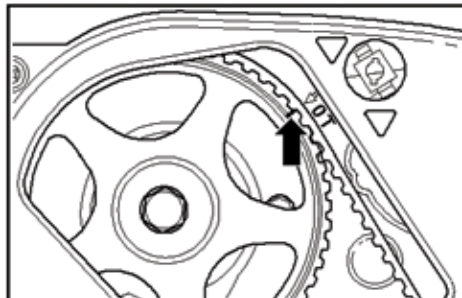
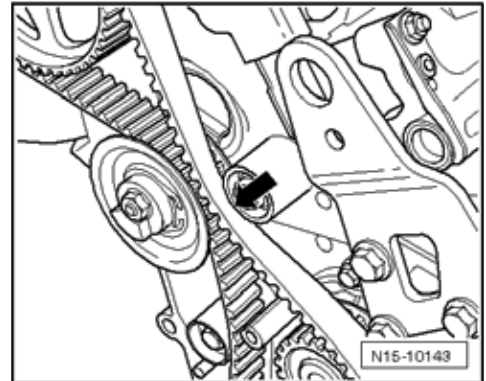

Con el cilindro #1 en TDC en su carrera de compresión, la marca en el engranaje del árbol de levas debe quedar alineada con la flecha en el protector de la banda dentada.

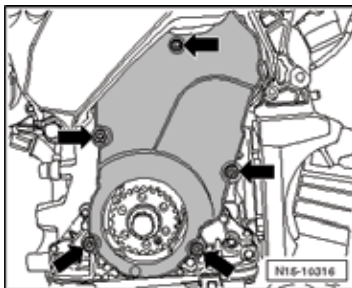

Estos son los cinco tornillos que sujetan la protección inferior de la banda en su lugar.

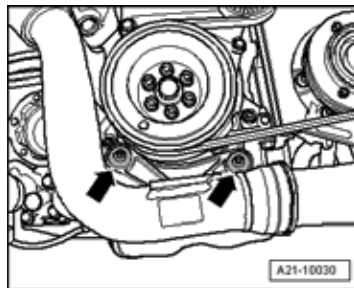

Dos tornillos sujetan al tubo del refrigerador de aire en el lugar. Tendrá que quitar los tornillos y el tubo para tener acceso a la banda.

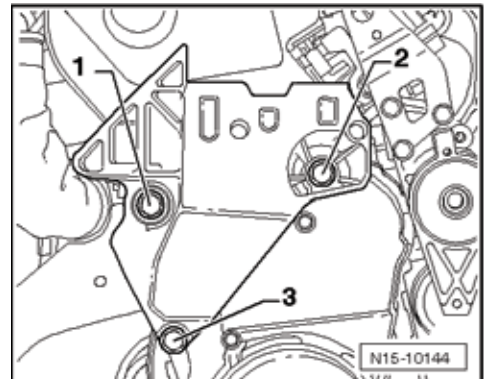

Aquí están los tres tornillos que sujetan el soporte del motor al bloque.

asegurar que tanto el cigüeñal y árbol de levas están en el TDC. Pero dado que éste es un motor de interferencia, si gira el árbol de levas con el cigüeñal a TDC, corre el riesgo de pegar las válvulas con los pistones que sería una unión inadecuada. Así, es mejor ajustar el árbol de levas a TDC primero y luego el cigüeñal.

Con el cigüeñal y el árbol tanto en el PUNTO MUERTO SUPERIOR (TDC), coloque la banda de tiempo en el orden siguiente: Engranaje del cigüeñal, luego el rodillo del tensor semiautomático y, a continuación, el engranaje del árbol de levas, la bomba de agua, y finalmente en la polea del amortiguador.

En el proceso, asegure que el rodillo tensor esté firmemente asentado en la cabeza.

El ajuste de la tensión de la banda nueva es un paso crítico. Primero tiene que apretarla en exceso, girando la excéntrica en el sentido de las agujas del reloj hasta que la ranura se encuentre encima de la pestaña. Después, aflojar la banda y volver a tensar hasta que alineen la ranura y pestaña. Ahora, apriete la tuerca en el rodillo tensor semiautomático. Para su confirmación, haga girar el cigüeñal dos vueltas completas, en la dirección normal de rotación, dé vuelta a la posición de TDC, con los últimos 45 grados de rotación girando sin interrupción. Volver a verificar para asegurarse de que la muesca y pestaña todavía están alineadas. Este modo se confirma que el cigüeñal y árbol de levas están bien sincronizadas. Confirmar la sincronización por observar el alineamiento de las marcas de los engranes del árbol de levas y de su caja.

Después de eso, el rearmado es básicamente una reversión del procedimiento de desmontaje, con algunas precauciones:

- Instale de nuevo el balanceador armónico usando nuevos tornillos.
- Revise cuidadosamente las señales de sincronización, asegurando que las flechas se alineen.
- Note que el soporte del montaje de motor es asegurado por dos tornillos de la misma longitud y un tercer tornillo que es un poco más corto que los otros dos. Este tornillo más corto se usa en el hueco más abajo.
- Observe que el procedimiento de alineación del soporte de motor, asegurando espacio apropiado alrededor de los componentes del motor.
- Use las especificaciones de la torsión apropiadas para todos los sujetadores.

Location, Location, Location



To find dealers, inventory, and special offers near you, visit:

[www.vw.com/
find-a-dealer/](http://www.vw.com/find-a-dealer/)

BPY especificaciones de torque:

Tuerca del rodillo tensor semiautomático:	25 Nm
Balanceador armónico:	Tornillos 8.8 - 10 Nm + 90 grados (vuelta 1/4). Use nuevos tornillos.
	Tornillos 10.9 - 20 Nm + 90 grados (vuelta 1/4). Use nuevos tornillos.
Tornillos del montaje del motor (3):	45 Nm. Use nuevos tornillos.

Para todos los otros sujetadores consulte la siguiente tabla: Especificaciones de torque

Tamaño de los pernos y tuercas		
M6 - 10 Nm	M10 - 40 Nm	M7 - 15 Nm
M12 - 60 Nm	M8 - 25 Nm	

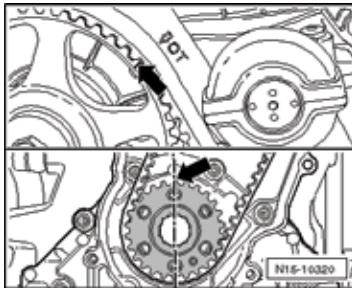

Antes de instalar la banda dentada nueva asegurarse que las marcas de tiempo en las ruedas dentadas estén alineadas para que el cigüeñal y árbol de levas precisamente en el TDC.

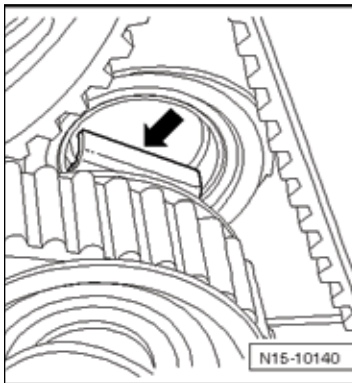

Esto muestra un montaje correcto del rodillo tensor automático.

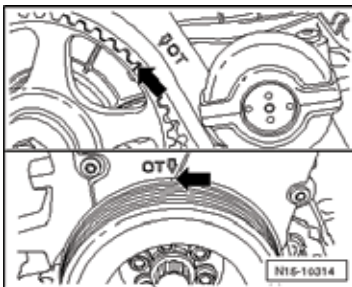

Para montar la banda de tiempo nueva, observar el orden adecuado de ensamblaje y hacer el último paso de la banda alrededor de la polea del amortiguador.

¿Qué Tal el Tipo de la Cubierta Simple?

El procedimiento para el cambio de la banda de tiempo en el diseño del motor anterior con la tapa de la banda simple es similar a la del diseño de dos piezas. Sin embargo, el trabajo es más intensivo porque el motor debe elevarse más alto con el fin de obtener acceso y retirar la tapa entera. Por esta razón, es necesario desconectar ambas flechas de la transmisión y también quitar el tubo de escape delantero con el catalizador con el fin de permitir levantar el motor a la altura adicional necesaria.

Eliminando estos pasos adicionales fue lo que motivó a Volkswagen actualizar el diseño de dos piezas en modelos posteriores y hay relativamente pocos de los carros anteriores con la tapa simple.

En cualquier caso, el reemplazo de la banda de sincronización es un procedimiento importante que deba realizarse como programada con el fin de evitar daños al motor principal, de la talla de los cuales todos hemos visto, con sus consecuencias tan feas. Su departamento local de partes, concesionario Volkswagen, puede proporcionarle con la banda de la calidad, los sujetadores y la bomba de agua que necesitará para este trabajo, y su cliente puede continuar su manejo, confiado que las válvulas y pistones felizmente mantendrán su distancia el uno del otro. ●

Un Juego Completo Funciona Mejor

Puesto que hay ciertas partes que deben cambiarse siempre, mientras está instalando una nueva correa de tiempo en un motor de VW, la buena gente de Volkswagen ha empaquetado convenientemente las piezas apropiadas en juegos completos de reemplazo de la banda de sincronización. Estos juegos, disponibles para ambas aplicaciones, gasolina y diésel, típicamente incluyen una banda dentada nueva, un nuevo tensor, nuevos rodillos de transmisión, y si sean necesarios, sujetadores que deben ser reemplazados en el proceso. Mientras no se incluyen en estos juegos, se recomienda comprar y cambiar la bomba de agua y la banda de accesorios durante este servicio, ya que la mano de obra es bastante intensivo y cambiarlas ahora, ofrece buen valor para el cliente.

Una lista de aplicaciones populares aparece entre las páginas 10 y 11; asegúrese de consultar con los profesionales de partes VW para el juego exacto del auto que está reparando.



VWParts.com

Your **COMPLIMENTARY** all-in-one resource for Volkswagen mechanical and collision information.

How convenient.

VWParts.com features:

- 24/7 online parts ordering
- Exclusive Tech Talk video series
- Mechanical and collision repair tips and VW position statements
- VIN decoder, tire fitment guide, fluid capacity charts
- Deep discounts at VW Parts Outlet Center



Maintain your customer satisfaction by staying in the know.

Sign up for VWParts.com today. It's fast, COMPLIMENTARY, and easy!

Goodbye Cable! Volkswagen's Throttle-by-Wire

This state-of-the-art system has been around for a while. You should know how it works. Today's technician also needs to know how this system integrates into the big picture of engine management. Let's also look in to the need for proper connections in this system.



Throttle-by-wire made its first appearance in Volkswagen vehicles in 1999 with the adoption of Robert Bosch Motronic ME 7 engine management for the 2.8L VR-6 engine, as found in this Passat.



Many of us technicians were shocked when we first heard of the concept of throttle-by-wire (or, drive-by-wire). What, no positive, mechanical connection between the driver's right foot and the throttle blade? No traditional and completely-safe control of engine acceleration? Whew.

Believe it or not, electronically-controlled, electric motor-powered throttles first appeared in Volkswagens with the adoption of Robert Bosch Motronic ME 7 engine management back in 1999 for the 2.8L VR-6 engine, then in 2000 for the 2.8L 5V V6 and the 1.8L 5V turbo. In all the years since, it hasn't actually been the big technical nightmare you might have expected it to be, and to our knowledge no accidents because of it have ever been reported.

Basically, an electric motor rotates the throttle valve shaft through a set of reduction gears according to computer commands. Benefits over a simple cable? More than you might think. Not only does it maximize engine torque and efficiency by keeping the velocity of the intake stream and manifold vacuum at higher levels than a human could ever do, it also allows cruise control without the necessity of adding a big vacuum actuator and attendant hardware.

Extreme safety measures have been designed into both the hardware and the software. Two position sensors are used for continual self-checking of signal plausibility. A safety module is integrated into the ECM to monitor the functional processor for proper operation.

One of the clever features of the design is that the two Throttle Drive Angle Sensors (G187 and G188) are opposite in resistance, and are used for continuous cross-checking by the ECM. The sensors are provided with a 5V reference voltage, then the ECM reads the voltage drop across these variable resistors and uses this to monitor throttle valve angle. The assembly including the throttle drive mechanism is designated G186. In later models, throttle-by-wire is integrated into the K132 Electronic Power Control (EPC) system.

An Aside on ME 7

Motronic ME 7, by the way, was the first torque-based system and also the first to consolidate processing of all subsystems in a sub-processor responsible for engine performance functions. Earlier systems used separate sub-processors for such things as ignition, fuel, or emissions controls.

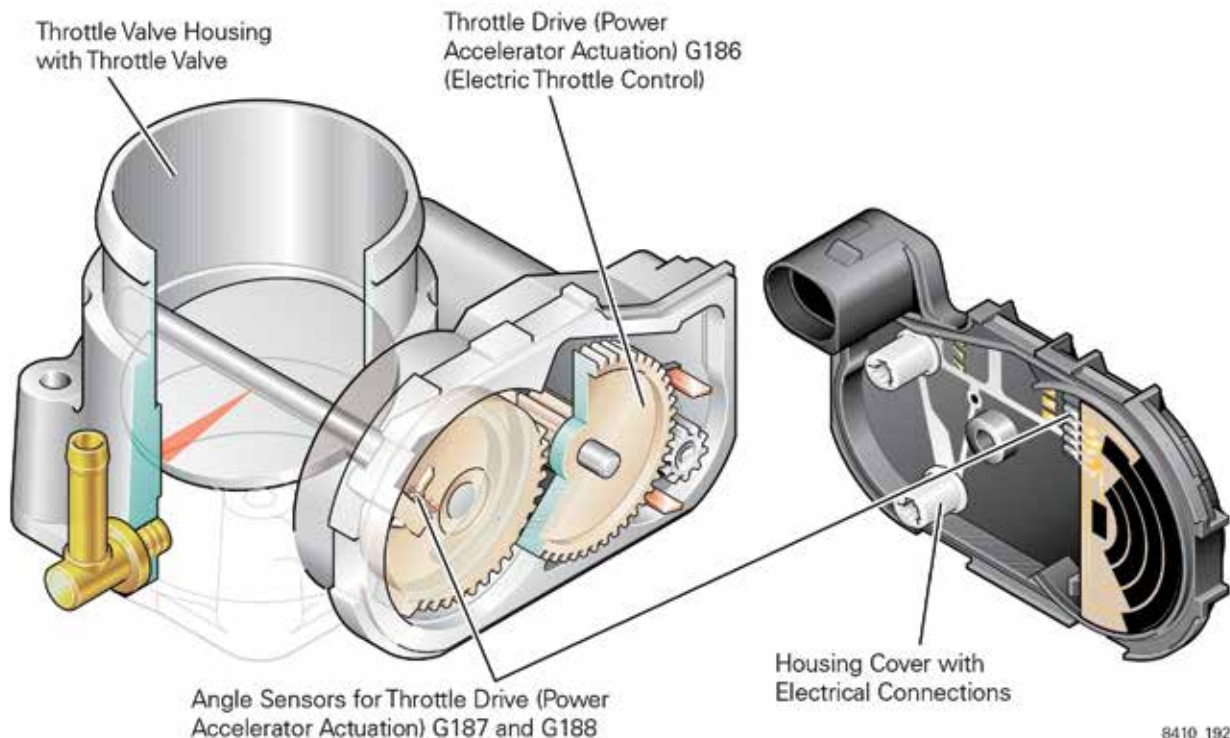

The electronic throttle valve assembly isn't actually that complex. Essentially, an electric motor rotates the throttle valve shaft through a set of reduction gears according to computer commands.

It also allowed cruise control to be integrated into the ECM, which is given the authority to hold and change the throttle valve angle as the previously-used vacuum pump did with much less intelligence. This allows for a more accurate transition of throttling as well as a more stable speed. Similar to M5.9.2 systems, the Brake Pedal Switch (F47) and Brake Light Switch (F) are combined in a single housing. One side controls normal brake light function, and the other lets the ECM know that the brakes are being applied so it can disengage cruise.

Motronic ME 7 brought about several changes in, and additions to, components for both engine management and other related functions. Besides Electronic Throttle and cruise control, these include:

- Charge Air Pressure Sensor (G31)
- Integration of the Barometric Pressure (BARO) Sensor (F96) as a component of the Engine Control Module (ECM, J220)
- Turbocharger Recirculating Valve (N249) -- Using an electrically-operated solenoid valve to manage activation of the bypass valve allows for more accurate control of charge pressure bypass during throttle changes (refer to Self-Study Program 892303).
- Dual stage intake manifold with an ECM-actuated Intake Manifold Tuning (IMT) valve (N156)
- Dual ECMs (W12 only)

For more information on ME 7, refer to SSP 842003.



Even the latest models such as this Tuareg II 4.2L V8 with MED 9.1.1 engine management use essentially the same electronic throttle system, just with a bigger bore than you're probably used to seeing on Volkswagen engines.

Pedal Module

The accelerator pedal module combines the accelerator pedal and the accelerator position sensors into one assembly. The electronic components of the pedal module are:

- Throttle Position (TP) Sensor (G79)
- TP Sensor (G185)

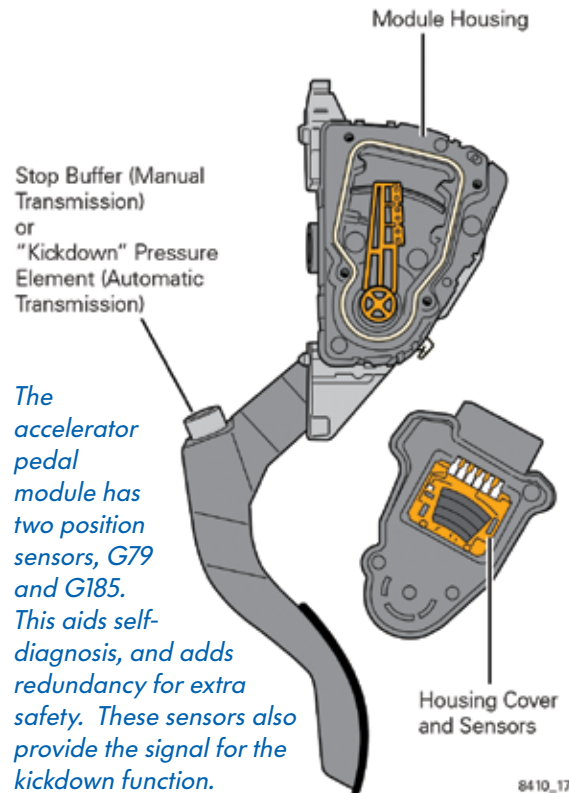

8410_174

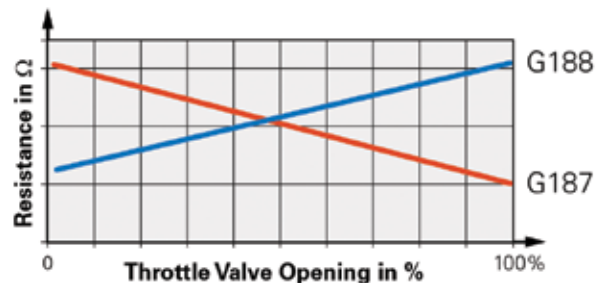

8410_176

One of the intelligent safety measures in the design is that the two angle sensors in the throttle body assembly are opposite in resistance, allowing for continuous cross-checking by the ECM. In later models, throttle-by-wire is integrated into the K132 Electronic Power Control (EPC) system.

The redundant throttle position sensors are linear to each other on different scales. Like the dual throttle drive sensors, the duplicate sensors are for self-diagnosis. They also provide an analog signal to the ECM referencing accelerator position, and the kickdown function is incorporated into the module. If the driver activates the kickdown, the full-throttle voltage of the accelerator pedal position senders is exceeded. The ECM interprets this as a kickdown and sends a signal the Transmission Control Module (TCM) by way of the CAN data bus.

If one of the TP sensors fails, the ECM relies on its companion sensor for redundancy. If both TP sensors fail, an Emergency Running Mode is initiated -- fast idle, but no throttle response.

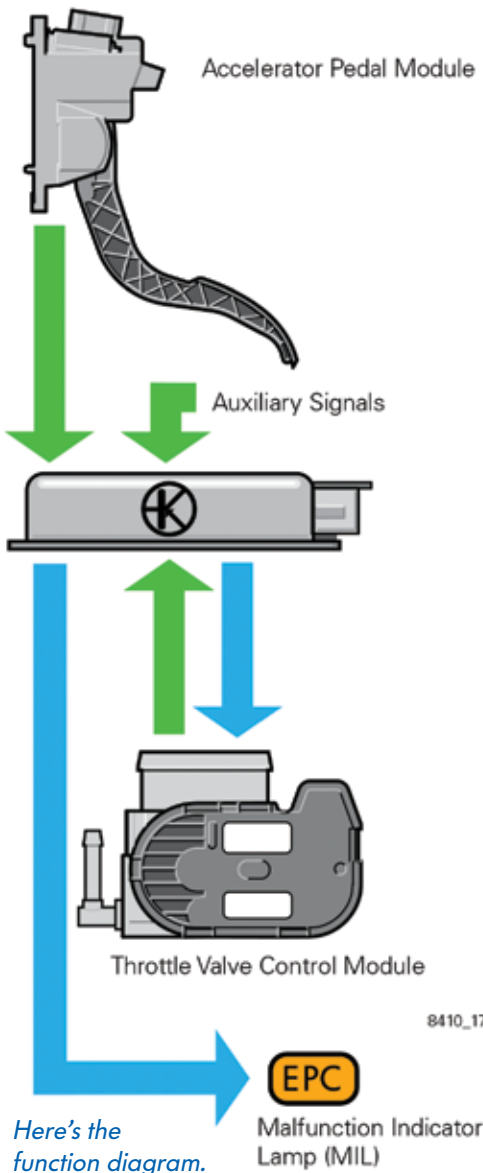

Warning!

In addition to the universal OBD II MIL (Malfunction Indicator Lamp), a separate fault indicator light (K132) is used for EPC. Malfunctions in either the electronic accelerator system or associated sensors are detected by the self diagnostics, and are indicated by the separate EPC warning light. For example, a fault in the Mass Air Flow (MAF) sensor (G70) signal triggers the EPC warning because the ECM uses it for input on engine load. The computer also references this signal to check the plausibility of other inputs. When a problem is detected, an entry is made in the fault memory. The ECM is able to recognize range/performance faults, as well as signal range checks for the angle sensors. The G186 is monitored for range of operation and idle adaptation faults.

When the ignition is switched on, K132 is illuminated for three seconds. If no faults have been detected, it goes out. K132 is activated by the ECM, which turns it on by providing ground.

From the Field

With this system having been in use for so long and on so many models, some problem patterns have naturally shown up. The most obvious, of course, would be the illumination of the EPC "Fault Light" on the dash, typically located in the tachometer face. As already mentioned, when malfunctions in either the electronic accelerator system itself, or associated sensors or wiring, are detected by the self-diagnostics, they are indicated by the illumination of this separate warning light, and an entry is made in the fault memory.

Reports from techs in the real-world trenches of auto repair indicate that other symptoms sometimes appear, often in confusing combinations and especially on early models. For example, you may encounter a specimen wherein engine rpm does not respond to pressure on the accelerator and stays at a fast-idle speed (although very high revving has also been mentioned). A likely cause of this condition is that the ECM has initiated an "Emergency Running Mode" (sometimes called "Limp-In") and is only allowing very limited vehicle operation with a high-enough idle speed to allow some forward progress, but nothing like normal highway speed. There is no substitute function for the throttle drive that can take over when this happens.

But what's causing it to happen? Most of you will immediately break out your scan tool (VAG or otherwise), pull codes, and pore over the data stream. That seems sensible, but our investigations point to the need to check some basics first, mostly wiring and connections for water infiltration (see if the sunroof

and cowl drains are clear), corrosion, or loose pins in the connectors. Junction boxes, especially near the battery, and various branch connections are especially vulnerable.

In some cases, the important grounds need to be re-established -- corrosion again. Unfortunately, this isn't always discovered until some expensive parts have been replaced, such as the throttle assembly, MAF, or even the ECM. This will, of course, be an embarrassment for the technician and the shop, which is why we always stress checking the basics of wiring and connections early in any driveability or performance diagnosis.

And it's not just rain water. One tech said he disconnected the coolant temperature sensor only to find that it was full of coolant. He replaced it, but still had the problem along with Code P1171, so he removed the connector at the ECU and found that the liquid had traveled all the way there. Cleaning that cured the no-throttle-response problem.

Four final notes:

- For all the electronic components to work properly, a system voltage of at least 11.5V is required. Check this first.
- Surging and stalling are other possible symptoms of trouble associated with throttle-by-wire.
- After you've replaced a throttle valve assembly, you absolutely must run the adaptation procedure (or, throttle body re-learn) of the ECM to the throttle control module (J338) properly. Refer to "Guided Functions" in the vehicle diagnostic tester. Throttle body position should be at 3% at idle and transition to 100% at wide open throttle. If other, related repairs have been

done and a problem appears, try running this protocol before you start blaming parts.

- We should mention the logical step of giving the throttle body a thorough cleaning using acetone and a suitable brush. This simple maintenance job has cleared up many seemingly mysterious malfunctions, so it should be done early in your investigation. ●

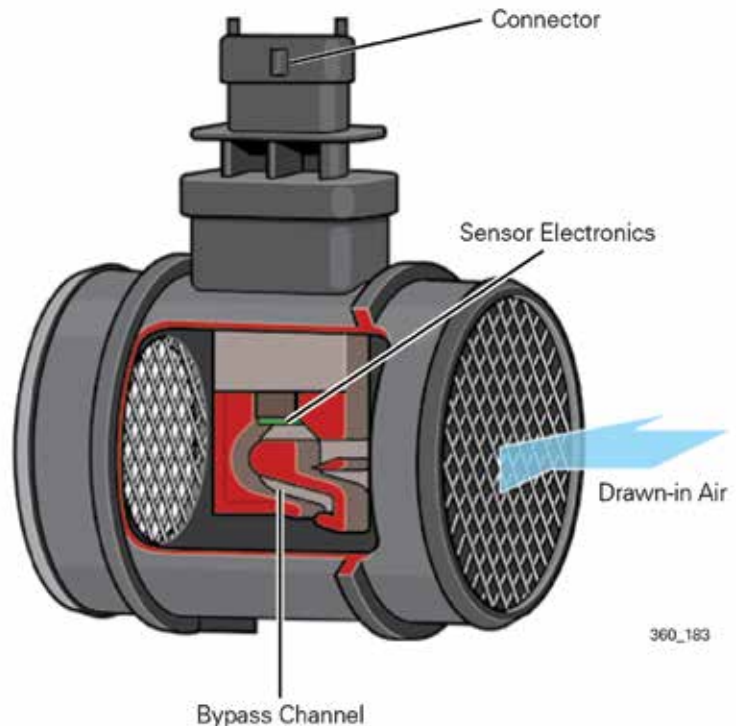

Related components, such as the MAF, can also turn on the EPC warning light.



Something as simple and easily-avoidable as a clogged cowl drain can cause infiltration of water into the wiring and electronic components.



Look at all that H₂O! Better start looking for this kind of trouble before you start replacing parts.

A technician in a white protective suit and red helmet is kneeling and using a spray gun. The background is a blurred image of a car body. The technician is wearing blue gloves and blue shoe covers. A red hose is connected to the spray gun. The PPG logo is visible on the technician's suit.

IN AN INDUSTRY JUDGED ON PERFORMANCE, ONE NAME ENDURES.

If you want to know where a company is headed, just look at where they've been. For over 111 years, we've served the automotive industry with market-leading products and expertise. Today, we're building on this legacy by investing in the technology required for decades of future success. Trust the name that stands the test of time. Partner with PPG.

PPG is an approved supplier to Volkswagen of America's Certified Collision Repair Facility program.

Follow us online:   www.ppgrefinish.com

Only one thing lasts longer than our coatings.
Our commitment to you.



PPG Automotive Refinish
Bringing innovation to the surface.®

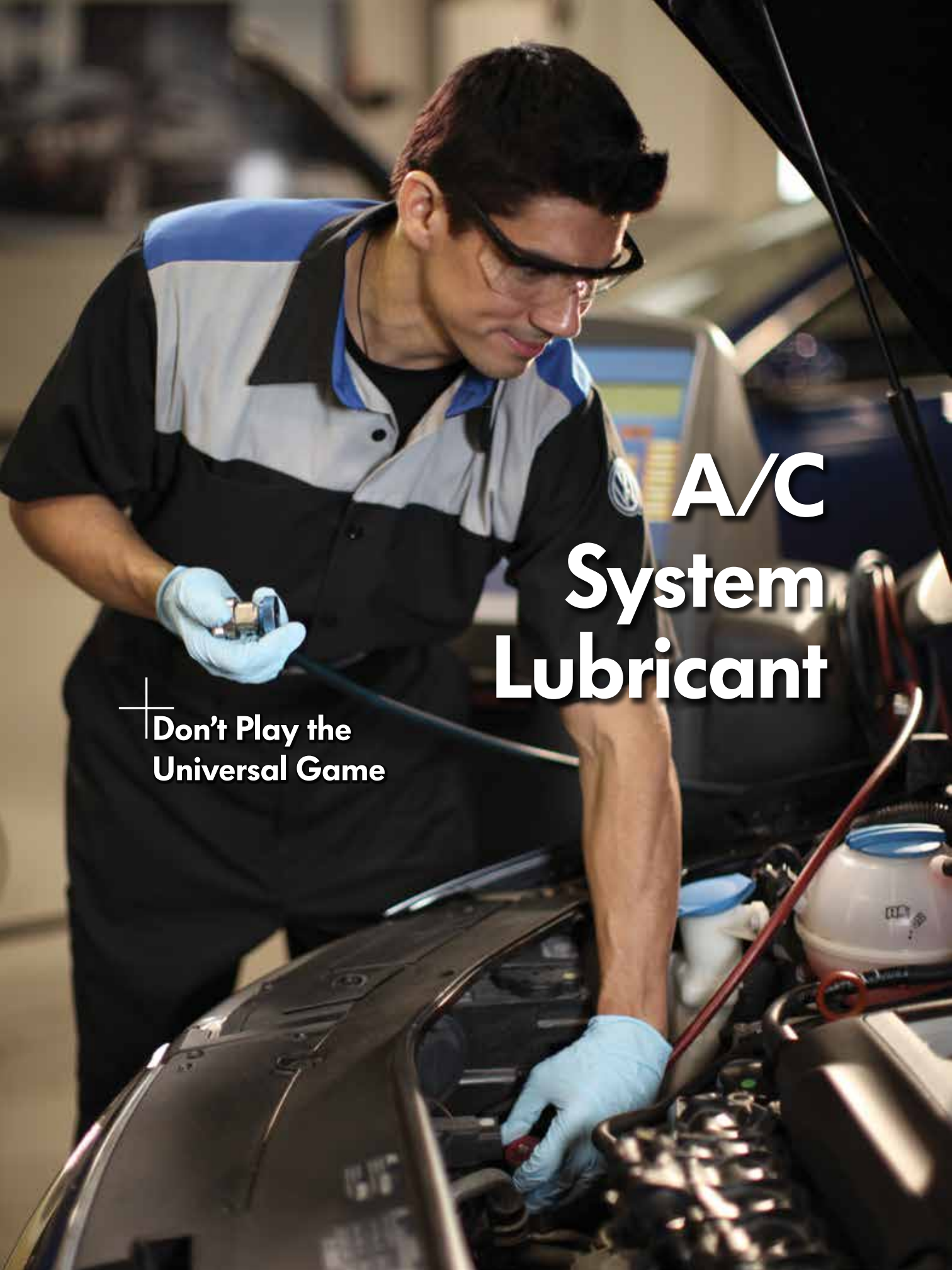

A/C System Lubricant

—
| Don't Play the
Universal Game



Lubricant issues are the number one cause of air conditioning compressor problems. Not enough, not the correct type, or inferior A/C lubricants are estimated to contribute to as much as one-third of all automotive compressor failures.

Lubricant transfers heat away from internal compressor surfaces, reduces friction, and help seal gaps between moving parts. If there is too little oil, the compressor will become noticeably noisy, overheat, and eventually fail.

Too much oil can cause slugging in the compressor, which can damage reed valves, piston rods, bearings, and other mechanical parts. Compressor discharge pressures will reach excessive levels and oil will coat condenser and evaporator walls, reducing heat transfer and passenger compartment cooling.

Today's savvy tech always checks in ElsaPro for VW dealers and erWIN for everyone else. A reminder that every great tech knows... Refrigerants don't mix (R-12 with R-134a) and neither do A/C Oils (Mineral with PAG) A/C repair and replacement procedures, torque specifications, oils and more can always be found Volkswagens 2 repair programs Elsa Pro and erWIN. Your parts person also has access to Volkswagens ETKA parts program that also lists A/C oils and more helpful info.

Different Types of A/C Lubricant

When vehicle manufacturers switched from R-12 to R134a refrigerant, they had to also switch from mineral oil, the lubricant used with R-12. Mineral oil is not miscible (does not mix) with R-134a, and so cannot be carried by the R134a refrigerant out of the evaporator. The resulting lack of oil in the compressor would lead to overheating, friction and wear, and eventually, compressor failure. The industry developed a synthetic oil -- polyalkylene glycol (PAG), which offers the necessary lubricity (ability of the lubricant to reduce friction between rubbing surfaces), and mixes well with R134a.

Since the 1993 Volkswagen has used PAG oil in its A/C compressors and R143a refrigerants. If techs encounter Volkswagen vehicles with R-12 systems, then Mineral oil most likely will be the lubricant required.

Opposite Page: Moisture can permeate through old-style A/C service hoses and enter the A/C system. New A/C Reduced Barrier Hose technology significantly reduces the rate and amount of moisture entering the system through hoses.

A lower-cost alternative, polyol ester (POE), also works with R134a, but offers less lubricity, which translates to less wear protection. In high-temperature compressor operating conditions, POE tends to break down and form acids that are corrosive to A/C system surfaces.

Three Popular Viscosity Grades

PAG is available in a range of viscosities (a measure of a lubricant's resistance to flow). The three most popular viscosity types are PAG 46 (thin), PAG 100 (medium thickness) and PAG 150 (high thickness). Viscosity Improver (VI) additives help each PAG grade to maintain anti-friction protection in an extreme-heat compressor operating situation, and at the same time offer excellent low-temperature flow capability.

Most Volkswagen models use PAG 46. Check the sticker under the hood for the A/C lubricant type and system capacity, or look it up on the VW ErWin or Elsa Pro, or other repair information database.

Don't Mix Lubricants

Volkswagen uses several different brands and types of A/C compressors in its vehicles, and some may require different lubricant than others. Never mix different types of lubricant in the same A/C system. Use only the type of lubricant recommended for the component being installed. An incorrect lubricant may not mix well with the refrigerant, this may be incompatible with seals or other material in the system.

Even mixing two different viscosities of the same type of oil is not recommended. The factory-recommended viscosity is specified for a variety of performance-related reasons. An incorrect viscosity can lead to lack of lubricant flow to critical moving parts. This can cause startup and high-temperature protection issues, settling of oil in the condenser or evaporator, or other problems.

New Compressor? Time to Flush!

If you plan to install a different make or model compressor than was in the vehicle when it arrived at your shop, always flush the system first to remove the existing A/C lubricant. Check the installation instructions that come with the new compressor to see what type and amount of lubricant to add.

Volkswagen recommends flushing with compressed air and nitrogen if you need only to remove moisture from the A/C system. For systems that have suffered a component failure that left behind debris or other contaminants, Volkswagen recommends flushing with

R134a refrigerant. Using R134a to flush the individual component that was compromised is more effective at removing debris and oil than using compressed air and nitrogen. Check ErWin, or your preferred repair information source for the Volkswagen advisory about proper flushing procedures. Check erWin and ElsaPro for proper flushing procedures.

Inspect what flushes out to see if there is metallic debris, corrosion, desiccant bits, or other contaminants in the system. If the previous compressor imploded or threw off contaminants, it is a good idea to replace not only the compressor, but most other system components as well. Accumulators, receiver/driers, and orifice tubes or thermal expansion valves (TXV) cannot be flushed, and should be replaced. Also, modern parallel flow and flat tube serpentine condensers have tubing that is narrower than the lead in a pencil, and are not responsive to flushing.

Balancing Act

Back in the days when you added three or four pounds of R-12 during a compressor replacement, the amount of oil you put in could be a loose estimate. In today's A/C systems that use less than one pound of refrigerant, the amount of oil you add is critical. Too much, and some oil will settle in the condenser and obstruct refrigerant flow, causing a loss of cooling. Too little oil and you increase the risk of compressor failure due to lack of lubrication.

If you're replacing a compressor, the traditional means of determining how much oil you should put in the new unit is to drain it into a measuring cup. You will need to be patient, and you should rotate the compressor shaft frequently during the process. Of course, you'll never get it all out. So, err on the generous side, but only slightly. Never overfill.

Fortunately, Volkswagen-approved replacement compressors ship with the proper ready-to-use lubricant so that you do not have to remove and replace oil during installation. If you

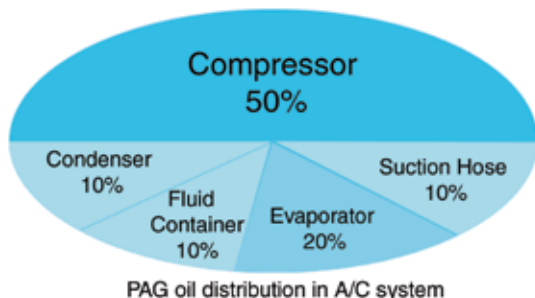

The compressor is the single largest user of lubricant in the A/C system.

are replacing only the compressor you should not have to pour in additional lubricant beyond what is in the replacement unit.

If, however, the A/C system was leaking, or other system components are being replaced at the same time, you may need to flush all oil from the system and start over. Check the installation instructions for the compressor or other component to confirm the amount of oil to add to the individual component. Add back the specified amount for each unit, then calculate how much, if any, you'll need to add to bring the system up to the recommended overall oil quantity.

After adding oil to the compressor, it is a good idea to rotate the clutch manually a few times before installation. Rotating the clutch lubricates the bearings and reduces the potential for a dry start, which can damage the compressor.

Oil and Water

Moisture contributes to aging of refrigerant oil, altering its viscosity and causing it to become corrosive towards metals in the A/C system. PAG, POE, and other refrigerant oils are hygroscopic, meaning they can absorb moisture from the atmosphere. PAG oil that has absorbed too much moisture will become viscous (thicker than intended) and darken in color.

Moisture enters the A/C system when service valves are opened, and if bottles are left open too long

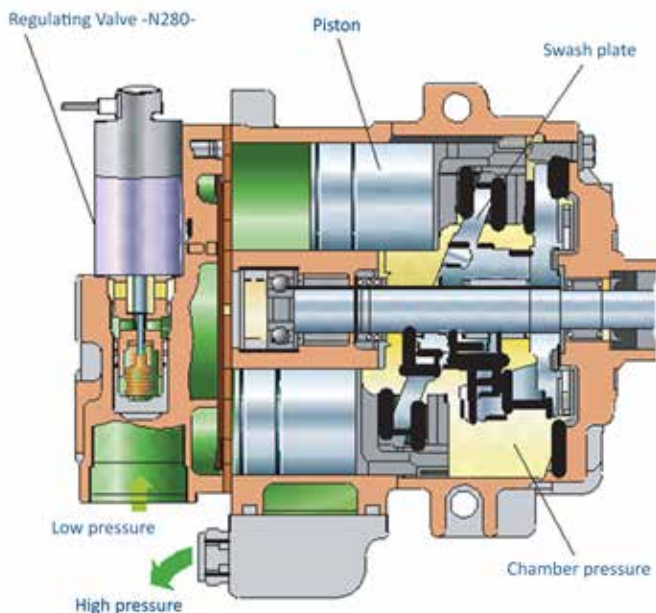

A variable displacement compressor (VDC) is always spinning whenever the engine is on. Ensuring a constant supply of lubricant is critical to the longevity of a VDC compressor.

before pouring lubricant into the system. Older hoses are also a culprit. As hoses age, they allow moisture to permeate through the hose material and into the A/C system. Newer barrier-type hoses reduce the potential for moisture to enter. New style service valves have been upgraded to contain a better O-ring seal, and to fit tighter onto the Schrader valve.

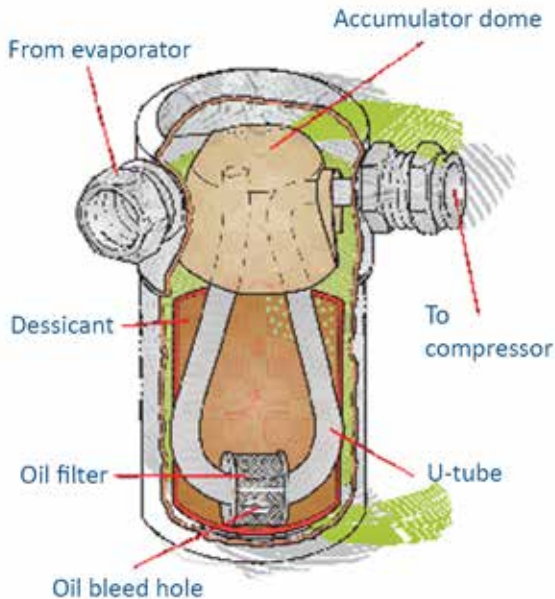

Desiccant in the accumulator removes moisture and separates oil from the refrigerant. To prevent the accumulator from trapping oil, there is a bleed hole with a filter screen in the bottom of the U-tube that carries refrigerant vapor and oil to the compressor.

Volkswagen recommends several actions to minimize moisture contamination in your A/C repair process. Replace the cap immediately after pouring refrigerant oil out of its container. Do not re-use refrigerant oil that has been removed from a damaged or open A/C system. Remove as much moisture as possible from the A/C system by pulling a vacuum to 29.9 inches of mercury for at least 30 minutes before charging with new refrigerant.

Double End-capped PAG Oil

There are two types of chemical structures for PAG oil as it relates to moisture. One type of PAG is formulated with one end of its molecular chain capped. The other end remains open, and can react chemically with nearby molecules. In the presence of high heat and moisture, an inferior grade of this single end-capped PAG can break down and contribute to the formation of acids that are harmful to the A/C system.

A second, double end-capped type has both ends of its molecular chain capped, or sealed in a manner that makes it non-reactive with other molecules. While all PAG oils are hygroscopic and absorb moisture, double end-capped PAG is chemically stable and will not react to moisture, even at high temperatures, to form harmful acids.

The bottom line is, provide your VW dealership parts counterperson with the VIN number of the car you're working on. You can be assured of getting exactly the right lubricant for the car you're servicing, rather than a "universal" lubricant that may not perform like the real McCoy. ●

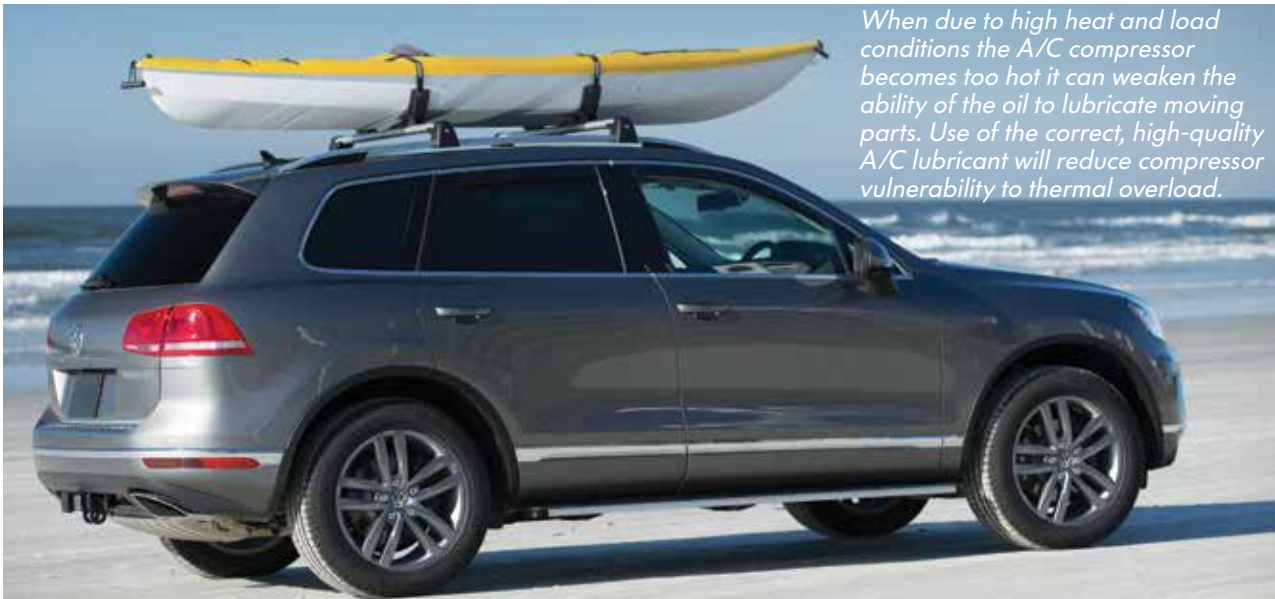

When due to high heat and load conditions the A/C compressor becomes too hot it can weaken the ability of the oil to lubricate moving parts. Use of the correct, high-quality A/C lubricant will reduce compressor vulnerability to thermal overload.

Wholesale Team

Special Team Focuses on Assisting Dealers Provide Genuine VW Parts to Collision Repair Facilities

The Volkswagen of America After Sales Wholesale Team, formed last year, has extensive experience in logistics, inventory management, sales/marketing, product management, communications, finance and dealer relations. Three team members have been given the challenge of focusing on assisting dealers

and independent collision repair facilities benefit from the Volkswagen storehouse of available VW components, systems and technical expertise to enhance business and build customer satisfaction. This special team is made up of Ashley Biggs, Alex Malyshev and Warren Barbee.

Alex Malyshev

is a Senior Financial Analyst at Volkswagen of America by day and races motorcycles by night. After graduating from George Mason University with a Bachelor of Science in Finance, Alex joined the Volkswagen Team and has been contributing in many areas of the After Sales business - most recently Wholesale Parts Operations. In his new role, Alex is working to support independent collision and repair shops on a wide range of initiatives including sales promotions, new product offerings and technical support information.



“The automotive wholesale business is dynamic and touches on a wide range of subjects. My goal is to work closely with our Dealer network and field force to create new sales and marketing opportunities.” In his spare time Alex can be found at the race track. “Road Atlanta is one of my favorites. Nothing beats preparing your race bike and going out to the track with your buddies on the weekend,” he admits.

Going forward, Alex is committed to working with Volkswagen dealers to strengthen their business and their relationships with independent repair facilities. •

Warren Barbee

“You only have to repair it correctly once,” quips Warren with his students as they move to complete a partial front rail replacement on a 2015 Golf Mk7. As a true man of the trade with over 40 years of experience in the collision and body repair trade he has done just about everything.

In July of 2012 Warren joined the brand-new Volkswagen Academy in Ashburn, Virginia as a Volkswagen Service Trainer and the Volkswagen Collision Technology Instructor. As well as designing the collision curriculum, he makes a significant contribution to service quality and customer satisfaction by teaching technicians the proper procedures to repair collision damaged Volkswagen vehicles.

He explains his role in this way, “Our purpose is to make certain that each technician at a Volkswagen Certified Collision Repair Facility or dealership has the proper training and a big part of our training is hands-on. We use Volkswagen approved equipment to install original equipment parts. Our training includes knowledge of Volkswagen approved repair



equipment and procedures to make certain that each vehicle is properly repaired back to Volkswagen standards.”

After attending intensive technical training at the original Volkswagen factory in Wolfsburg, Germany he received the prestigious Volkswagen Service Trainer Diploma. This endorsement authorizes him to teach Volkswagen Collision and Body Training anywhere in the world.

Warren takes his role as an ambassador in repair instruction for the Volkswagen brand very seriously, “The repair procedures we teach are so valuable. For technicians it starts with knowing how to repair collision damaged Volkswagen vehicles. Repairs are easier with a guide – for Volkswagen that’s ErWin and ElsaPro – our repair information databases available to CCRFs and dealerships. I always like to hear when my students take the knowledge back to their shops and apply it. Ultimately I know that what we do is highly important for technicians, shops, and Volkswagen owners.” •

Ashley Biggs

The Volkswagen of America Certified Collision Repair Facility Program Coordinator – is a new addition to the Wholesales Parts Operations team based in Herndon, Virginia. Ashley holds a Master's Degree in Business Management from the Hough Graduate School of Business at the University of Florida (Go Gators!) and has experience in retail management, sales, marketing and project management.



In her new job, Ashley is working with collision centers throughout the US and is responsible for guiding them through the Volkswagen of America certification process.

Her day begins seeking new ways to encourage sponsorships between qualified collision shops and authorized Volkswagen dealers. And that's just the beginning. Ashley works with every collision shop throughout certification process to ensure the partnership is successful.

Ashley summarizes her role in this way, "our goal is to make certain that each Volkswagen Certified facility has the tools and training necessary to successfully repair each Volkswagen that comes through their service bay. We want our Volkswagen owners to receive quality repairs performed by trained technicians with the intent that every vehicle is repaired back to the original factory standards using VW original equipment parts. It's exciting to be working in such a dynamic industry with professionals that are dedicated to their craft and the Volkswagen brand."

"Volkswagen's Customer Relationship Management (CRM) program is a really important element to Volkswagen after sales and customer satisfaction, and fits right into our team's efforts. Designed to help VW dealerships manage and enhance interactions with current and future customers, the program organizes, automates, and synchronizes sales, marketing, customer service, and technical support. It adds efficiency and time savings for the dealerships as it provides support for their sales efforts," Biggs said.

"In situations where a Volkswagen owner goes elsewhere for collision or other repairs when needed rather than returning to the dealership, utilizing CRM can help the dealer make sure the shop that he or she patronizes purchases and installs genuine original equipment parts purchased from the dealership. This is a win-win for all concerned -- the dealership, the independent shop, and highly important, the vehicle owner," she said. •

Location, Location, Location

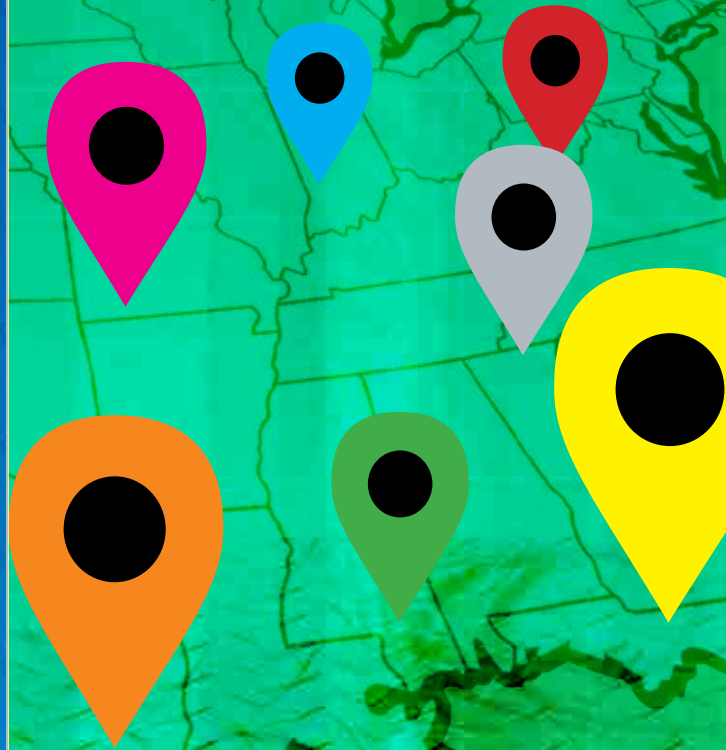

To find dealers,
inventory, and special
offers near you, visit:

vw.com/find-a-dealer/

Best in the Business:

The Volkswagen Genuine Parts Warranty





+ Sure, there are some things you could get from the aftermarket, but nothing good happens if they fail.



For a technician working in an independent repair shop, the feature he's looking for most in replacement parts is confidence -- confidence that the part will fit and function properly, that it will provide a long service life, and that the manufacturer will stand behind it if for any reasons it fails to meet his expectations.

That is why Volkswagen develops very demanding engineering specifications for every component of its vehicles. They then test each component against those specifications, in computer simulations, in lab tests, in pre-production models, in short and long-term road tests, and in many other ways. By the time a new Volkswagen model is available for sale, every component has been validated for performance, fit and finish, durability, and a variety of additional factors critical to its ability to provide a long and useful service life.

Their stringent engineering specifications and rigorous validation procedures enable Volkswagen to offer a 12-month or 12,000 mile replacement warranty on all new or factory remanufactured replacement parts (excluding tires and batteries) sold to their dealers' customers. The Volkswagen warranty is your assurance that the part will work exactly as the original. It is the same as the factory-installed part. It will fit the same, have the same installation procedures, and provide the peace of mind of having been made specifically for the vehicle application. These are the three key criteria for replacement parts -- fit, form, and function.

The Volkswagen emissions parts warranty covers defects in key system components, including the catalytic converter, engine electronic control module, exhaust manifold, fuel tank, and malfunction indicator light for seven years or 70,000 miles, whichever comes first. Different warranty lengths cover other emissions-related components, depending on the Volkswagen model and year. Check the Volkswagen owner's manual or warranty booklet, [VW ErWin.com](http://VW.ErWin.com) or other online maintenance information source for details about warranty coverage of specific components and vehicle models, or ask your VW parts representative for details.

If the vehicle is registered in a state that has a vehicle emissions inspection and maintenance program, and fails an emissions inspection due to a defect in a certain emissions-related components, Federal law requires warranty coverage for eight years or 80,000 miles, whichever comes first. Parts with an explicitly stated replacement interval, such as

“replace at 12,000 miles or 12 months,” are warranted up to the first replacement interval only.

The Promise of Equivalent Performance

The Volkswagen warranted part will, when properly installed, deliver performance equal to that of the factory-new component. We can see the function tradeoff when we compare an aftermarket air conditioning evaporator to a genuine VW replacement unit. The aftermarket evaporator may be the same size and look similar, but may not be able to remove the same amount of heat from the air.

With an aftermarket unit your customer may find that his or her A/C system is running four or five degrees warmer than it should. That may not rise to the level of customer complaint in Maine or Wisconsin. If, however, you are in hot, humid Georgia or Florida, or the oven of the desert southwest, every BTU counts.

Similarly, you could purchase an inexpensive white-box A/C condenser from certain overseas sources. If because of the design, the condenser is not shedding as many BTUs as required for the Volkswagen model in which it is installed, it may cause harm to other A/C system components. The compressor will have to work harder, cooling performance will suffer, and system reliability may decrease. A warranty-backed Volkswagen OE part gives you confidence that you will get the performance required for the application.

This rear lip spoiler offers the exact fitment, color and finish match for a 2011 Volkswagen Jetta. Installation is easy and when properly done, maintains the Volkswagen corrosion warranty.



Application-specific Design for Proper Fit and Function

Aftermarket parts are made to fit a wide variety of vehicle makes and models. That can cause situations where installation requires extra labor to make the part fit.

For example, aftermarket muffler suppliers consolidate shapes and styles down to a small number of different designs in order to reduce the number of SKUs retailers must stock. The muffler may meet vehicle performance specifications, but require the cutting of connecting tubing, or addition of special adapters or extensions, or other alterations to the original factory layout. This necessitates extra labor and introduces the possibility of installation error. Furthermore, the use of universal exhaust hangers can lead to annoying rattles and customer dissatisfaction.

Genuine Volkswagen mufflers are application-specific in shape, size and connector types. They fit without altering factory layout, eliminate extra labor steps and reduce error potential. This is one more reason Volkswagen can be confident in backing up its replacement parts with a solid yet simple factory warranty.

As with mufflers, aftermarket suppliers typically consolidate catalytic converters to reduce inventory requirements. However, in most cases this compromises the installation process, requiring adapters and expending valuable technician time. Furthermore, the capacity and efficiency of a universal converter will certainly not be ideal for every application. With a genuine VW part you can be assured that installation will be straightforward and performance will be identical to the original part.

And the story is similar with oxygen sensors, where universal designs greatly reduce inventory requirements for the auto parts store, but make for installation and possibly performance headaches for the installing technicians. Adapters may be needed for electrical connections, pigtailed may be too short, and it may even be necessary to splice wires, which is time-consuming and presents a venue for future corrosion, electrical resistance, and failure of the part to perform. Plus, universal sensors likely will not be properly calibrated for the various applications for which they're catalogued. With a genuine VW O₂ sensor you can be assured of exact fit and function.

Double the Corrosion Warranty

Most vehicle manufacturers warrant their body panels against rust-through for four to six years. VW offers a corrosion perforation warranty of up to 12 years, depending on the model, with no mileage limit. Of course, only Genuine Volkswagen collision parts qualify for the Volkswagen Corrosion Perforation Limited Warranty.

This superior warranty is possible because Volkswagen replacement body panels are built to the same specifications and manufactured in the same factories as Volkswagen new car parts. They offer the exact same fit, finish and quality as original equipment parts because they are OE. As such, they afford the same safety and occupant protection as the panels the car was born with, which is often not the case with aftermarket body parts stamped from thinner-gauge metal, and possibly not the same type or strength of reinforcements.

This replacement muffler for a 2010 Volkswagen Jetta features tubing in the proper locations and angled to fit the original factory layout. The technician will not have to spend extra labor time bending or cutting tubing to fit around nearby components, or adding adapters to fit the connectors on key Volkswagen system components.

A Focus on Professionals

A warranty is more than just a statement of quality. It is also about the market for the products covered.

If you've ever returned a mechanical part to an auto parts retail store, you've likely faced a product evaluation process that delayed replacement of the failed unit or refund of your money. An auto parts store that deals with a high percentage of do-it-yourself customers is more likely to suspect misdiagnosis and ordering of the wrong part. The store will thus be skeptical of defect claims. This suspicion of misdiagnosis tends to skew their warranty claim process toward a higher requirement of proof that the customer received a defective part.

The parts counter in a Volkswagen dealership offers a much more hassle-free warranty claim process because they sell primarily to professional technicians that are less likely to misdiagnose the vehicle problem or order an incorrect part. If you are a technician in a shop that is a regular customer, the Volkswagen parts counterman is much less likely to interrogate you when you return a part, just to make sure you did nothing to damage it during installation. Returning a battery? The dealership is unlikely to make you wait while they charge and test it to verify your claim that it will not hold a charge.

So take comfort in buying and installing genuine VW replacement parts, knowing they're built to the same exacting standards the car was designed with, and backed by a hassle-free warranty that protects both you and your customer. ●



Global Rallycross Brings Red Hot Beetles, Exciting Racing to Unique Road Tracks



Beetles on the track are instantly recognizable.



Looking for some real good road racing, with 553 horsepower Beetles that do 0-60 in two seconds running up front with the pack? Check out Red Bull Global Rallycross racing, a fresh series on tracks that feature hardtop, dirt, a jump, and lots of excitement.

The slam bang action features Volkswagen, Ford, and Subaru cars, which start out life ostensibly as production vehicles but are pumped up to 500-600 horsepower and set up to race full bore on tracks that really test what they're made of – and the drivers as well.

In addition to fire-breathing powerplants, the cars get significant upgrades to chassis and racing spec safety features, and are ready for anything the track throws at them. Accelerating from 0-60 mph in about 2 seconds – as fast as a Formula 1 car – they are set up to withstand 70-foot jumps and virtually constant door-banging contact with other vehicles on the track. Designed and engineered specifically for the Global Rallycross series, the racing Beetles run with a 553 horsepower, 2.0L four-cylinder TSI® turbocharged and intercooled engine, mated to a sequential six-speed transmission and fixed-ratio all-wheel-drive. They run without electronic traction aids, enhancing the excitement.

The Beetle projects “Volkswagen”

With the cars formerly running the Global Rallycross basically similar in size and appearance, Volkswagen decided to bring the Beetles to the races to make an easily recognizable statement for the brand. There is no mistaking the Beetle, it is known all over the world, and says “Volkswagen” to everyone who sees it. The Global Rallycross race series is a natural to project a highly positive Volkswagen image to thousands of motorsports fans and savvy drivers throughout the country.

The Volkswagen Andretti Rallycross team brought two red hot Global Rallycross Beetles to the series at the Los Angeles race last year, replacing two Polos which had been in the series, and the Beetles are poised to take on the field in 2015. Scott Speed, No.77, and Tanner Foust, No.34, are piloting the two Beetles. Speed and Andretti Autosport owner Michael Andretti

are the last two American drivers who competed in Formula 1, and Foust is a two-time Global Rallycross champion and popular driver in other activities.

The Volkswagen Andretti Rallycross team finished its first Global Rallycross Championship season with strong performances, and the two GRC Beetles began the final round in Las Vegas with four heat wins. Speed and his 7UP Volkswagen suffered an early incident in the final race and was forced to battle back from the back of the grid, sidetracking a run to win the driver championship. He finished fourth in the race and third overall in the championship. Tanner Foust and the Rockstar Energy Drink Volkswagen won his first two heats, but a broken toe-link from contact with another driver forced Foust to race in the last chance qualifier and the final, taking home a sixth-place finish. Series winner Joni Wiman took the 2014 championship title in the No. 31 Ford Fiesta.

Beetles start series running strong

“The GRC Beetle was running strong all afternoon in the second round of heats,” said Speed. “It’s unfortunate that I had to restart from the back of the grid during the final, but it definitely showed the toughness of this new car. Running the Beetle in Las Vegas has been great and it sets us up nicely going into next year.”

“Finishing in sixth place tonight in Las Vegas feels pretty good after a rocky start to the season,” said Foust. “These last few races of the season have been great for the development of the Beetle. We have learned what works and the amount of run time each piece of the car needs. The Beetle should be tough to beat in 2015, so I’m looking forward to running it all season.”

Season opens at beaches of Ft. Lauderdale

Global Rallycross opens the 2015 season in Ft. Lauderdale, racing on city streets in front of the Bahia Mar Resort & Marina. Scott Speed won 2014’s season opener in Barbados, where the next to last race this year will be held.

GRC tracks are between half a mile and a mile long, a mixture of dirt and tarmac, and include a mandatory jump, other obstacles, and can be set up and built almost anywhere. Worldwide, GRC drivers can also be

veterans of careers in Formula 1, NASCAR, motocross, BMX and skateboarding, and include former World Rally champions.

A Penalty Box deals with on-track infractions and avoids red flags or restarting the race, and holds offenders in a 50 meter off-track lane until a track official releases them. If an infraction occurs too late for Penalty Box use, a time penalty is assessed.

Rounds of heats lead to semifinals at each race

Racing begins with two rounds of heat races, normally four cars and six laps each, running for up to three points. The field is then combined into two groups of equal size for the semifinals, which are also six laps each. Top three finishers from each semifinal transfer into the main event, while their teams work on their cars as others compete. Drivers who do not make it into the main event via heat races compete in a four-lap last chance qualifier for final qualifying spots.

Ten cars then compete in the full bore 10-lap main event. The 2015 Global Rallycross Championship schedule, the largest to date, includes races at eight unique tracks with some double headers. This new series produces fast and exciting racing while allowing spectators to wander through the pits and rub elbows and interact with drivers and their crews as they twist the wrenches.

Drivers are awarded championship points relevant to their standing in each race.

And don't forget, if you miss the races this year stateside, there's always the next to last race in Barbados.

Red Bull Global Rallycross races are broadcast live on the NBC sports network. ●



2015 GRC
race locations.

2015 Red Bull Global Rallycross Schedule

April 31: Ft. Lauderdale
June 20: Daytona, FL
June 21: Daytona, FL
July 5: United States
Military Base
July 25: Detroit, MI (I)
July 26: Detroit, MI (II)

Aug. 15: Washington, DC
Sept. 12: Los Angeles, CA (I)
Sept. 13: Los Angeles, CA (II)
October 3: Barbados (I)
October 4: Barbados (II)
Nov. 4: Las Vegas, NV



Tanner Foust goes over the jump!



The racing Beetles take the field replacing two Polos, which had been running the Global Rallycross series.



Scott Speed leads tight in a corner.



Scott Speed and Tanner Foust lead the charge.



CELETTE®

When repairing collision damage on a customer's vehicle **PRECISION IS VITAL**

A dedicated fixture bench is the most accurate & efficient way to ensure a damaged chassis is restored to original factory specifications.

Celette's® repair systems encompass options for light, to medium, or heavy hits. The award winning NAJA 3D Electronic Measuring System allows for quick diagnostics, while Dedicated Fixture Sets enable technicians to easily verify, measure and hold points for exact repairs on any Volkswagen model.

Sell peace of mind to your Volkswagen customers,

FIX IT LIKE IT NEVER HAPPENED

Celette is the only VW-dedicated fixture bench approved for the VW Certified Collision Repair Facility (CCRF) program.



Photos courtesy of Warren Barbee, Collision Technology Instructor



For more information: 1-800-CELETTE

contactus@celette-na.com

www.celette.com

Volkswagen's Certified Collision Repair Facility Program: Serious Support for Technicians

In a recent issue of VW TechConnect, we spoke about how the Volkswagen Certified Collision Repair Facility (CCRF) program is outstanding at helping service providers adapt to new vehicle technology and repair procedures. Here's a look behind the curtain at some of the ways the program supports collision repair facilities and their technicians.

Repair Prospecting

Dealers that sponsor a CCRF shop must at no charge refer all vehicles in need of collision repair to the shop that the dealer sponsored, whether independent or dealer-owned. This is no small thing. With the high level of complexity of today's vehicles, more customers call the dealer after an accident.

CCRF participating shops receive the right to use the VW logo to advertise and market the fact that the facility has received the coveted VW certification. Certified shops then get access to VW TRAC customer data to help them identify and promote their best-in-class status to VW owners in their market area. CCRF shops also qualify for referrals from the Allstate Roadside Assistance® program as well as VW employee fleet vehicles.

The company provides eye-catching signage, banners, and plaques for strategic placement where shops can inform customers that the facility is certified, and assure them that CCRF certification means their vehicle is in good hands.

As the late-night TV commercials say, "But wait, there's more!" VW maintains a website dedicated to supporting CCRF program participants with:

- A list of independent and dealer-owned collision repair facilities that have attained VW collision repair certification, prominently featured at VW.com.
- Position Statements that document official VW collision repair requirements
- Customer Release Agreements on use of VW Genuine Parts
- Links to repair information and repair training for VW vehicles
- Accident Guides that walk customers step-by-step through the process of getting their vehicle evaluated, insurance claim prepared and approved, and repairs completed quickly and with no additional stress.

Supporting Estimates

CCRF technicians can show VW Position Statements to insurance adjusters to support repair estimates. VW Position Statements are official documents that list the safety and effectiveness benefits of OE-mandated repair procedures, offer the repair durability reasons that Genuine Volkswagen parts are required for certain repairs, and provide the rationale for the application-specific repair equipment that is mandatory for certain collision repair procedures. VW position statements also help educate vehicle owners about the safety, driving comfort, and appearance benefits of Genuine VW Parts and repair procedures. Position Statements are provided at no charge to all CCRF program participants, and are available at vwccrf.com and vwparts.com.

erWin; Funny Name, but Serious Repair Information

Current technical bulletins, service repair manuals, wiring diagrams and other vehicle data are all available to CCRF program participants through access to erWin, the online repair information database from Volkswagen at <https://erwin.vw.com>.

For example, on some VW models, when airbags have been deployed and there is crash data stored which cannot be cleared, the airbag controller must be replaced. You may find the coding reset procedure in an aftermarket source, but in erWin you will also find links to updated information about crash sensors, airbag igniters, and other related components that, depending on the VW model being repaired, should be checked before installing a replacement airbag controller.



Certified facilities get bragging rights.



Volkswagen Academy: Cutting Edge Training

Have you heard about “tailored blanks?” They are structural components made with varying levels of thickness in different areas of the same part, depending on the strength required in each area. Want information about the new “Wobble Seam” joining



There is only one way to repair a Volkswagen – the right way, and the CCRF program provides access to all of the information needed to do it right the first time. Photo taken at VW Academy by Warren Barbee during a structural repair course.

technology that provides a laser weld that can handle a load four times greater than traditional spot welds? You can find details about these and more new repair technologies by contacting collision@vw.com.

Higher Customer Retention

All of the benefits to shops participating in the Volkswagen CCRF Program add up to greater customer satisfaction. Armed with factory technical information and field-proven Volkswagen repair training, technicians who are part of the Volkswagen CCRF program are better prepared to repair the vehicle in accordance with Volkswagen specifications and procedures. Repairs done properly the first time are absolutely critical to a facility’s ability to maintain a high customer retention rate.

Here’s How to Enroll

1. The dealer should send an email to collision@vw.com, and let us know you are interested in sponsoring a shop to become a CCRF participant. Tell us the facility name, location, phone number and primary contact person.
2. VW will respond to both the dealer and the nominated repair facility and begin the process of:
 - Evaluating the nominated facility
 - Providing assistance where possible to help the facility meet program certification requirements. ●

Volkswagen Academy

Collision Training Schedule - 2015

Date	Time	Course
July 8-9	8:30am - 4:00pm	Volkswagen High Strength Steel
July 10	8:30am - 4:00pm	The New Golf Mk 7
August 19	8:30am - 4:00pm	Beetle and Beetle Cabriolet
August 20	8:30am - 4:00pm	Jetta Hybrid Collision Repairs
August 21	8:30am - 4:00pm	The New Golf Mk 7
August 26-27	8:30am - 4:00pm	Volkswagen High Strength Steel
August 28	8:30am - 4:00pm	The New Golf Mk 7
September 16-17	8:30am - 4:00pm	Volkswagen High Strength Steel
September 18	8:30am - 4:00pm	The New Golf Mk 7
September 23-24	8:30am - 4:00pm	Volkswagen Collision Welding
September 25	8:30am - 4:00pm	Jetta Hybrid Collision Repairs
September 30	8:30am - 4:00pm	Beetle and Beetle Cabriolet

We are currently waiving course fees for our CCRFs and Dealer Network - enroll your technicians today!

Reserve seating is unavailable for any of the Volkswagen Collision Courses so send your enrollment form to warren.barbee@vw.com ASAP. For further questions contact ashley.biggs@vw.com or call 703-364-7642

AWARD-WINNING DESIGNS DEMAND WORLD-CLASS FINISHES



The world-renowned designs of legendary automotive expert Chip Foose have been recognized time and again with the industry's highest honors—including the coveted Ridler Award. And to bring all of his visionary masterpieces to life, Chip always relies on world-class Glasurit® finishes. You too can put the rich liquid color and deep brilliant gloss of Glasurit to work in your shop. Visit www.basrefinish.com/glasurit to learn more.

