

Solving Power Window Woes

This article will focus on where to start with diagnosing faulty window behaviors, how to troubleshoot window-related problems that develop as a result of other repairs, and how to properly QC check a vehicle to avoid unnecessary come-backs regarding the power windows.





This article will not cover how to physically remove and replace power window components. Instead, we will explore where to begin when trying to figure out what went wrong with the window and how to properly initialize window control systems. We will also explore some possible situations when another repair may incidentally cause window misbehavior, and how to anticipate these complications when recommending work. Lastly, a good quality control checklist can prevent delivering a project that might have incomplete initialization.

Where to begin with non-functional power windows

Take time to document the window behavior that the customer describes. You should also operate all windows, even if the customer describes only one with a problem. Do the automatic UP or DOWN modes function? Does the sunroof function? This baseline information ensures that after repairs are performed you know whether the window is fixed properly, and whether any other windows need additional attention. If you never check other windows, you might release the car with new problems that could have been identified.

Always engage brain before hands! Don't rip right into the door panel as your first course of action. The computer is the best tool in your arsenal to begin fixing any power window malfunction. With access to the Nissan TechInfo website (<http://www.nissan-techinfo.com>), you can easily find relevant TSBs and the official service manual for any Nissan you're about to work on. If there are no TSBs, then check the service manual to understand how the circuit is designed.

Once you've ruled out any relevant TSB or open service campaign, think about general possibilities for the malfunctioning window:

- Has the door for the window ever been involved in a collision?

- Does this door open and close properly without hyperextension?
- Does the window make any noises while operating?
- Does the window move slowly or otherwise bind at any point while going up or down?
- How do the driver's master power window switch buttons physically feel when operated?
- For other windows, how do the sub-switches physically feel?

Consider these bullet points before opening the door panel. If the door has been involved in a collision, all bets are off as to what may be wrong with the window! Knowing this might help you prepare the customer for possibilities prior to your labor investment. If the door's over-travel check is broken, the hinge wiring harness can hyperextend and break.

Noisy windows suggest potential problems with the regulator, window glass, or the rubber run. Excessive friction from the window glass binding on a dry window run can cause a window motor's internal circuit breaker to trip. The window might operate – slowly – until it stops working entirely for a period of time. Silicon-based wet lubricants can alleviate this friction without swelling the rubber. A window regulator should be investigated if abnormal noise and movement is observed during window operation. Likewise, window glass mount points should be reviewed if noises or erratic movement still exist.

Even if the customer insists that a regulator was replaced recently on the problematic window, many shops will use aftermarket parts whose fitment is questionable. Unless repairs are performed using genuine Nissan parts, even new window regulators can have fitment issues that result in loose mounting bolts or poor operation. Likewise, a vandalized window repaired by insurance may not have used factory window glass, and therefore the aftermarket glass

might be sized differently or have inaccurate mount locations.

The window switches are another area in which to look. Move the buttons on the switch and compare with the other switches on the same vehicle, or another known-good Nissan in the shop. It is quite common for a switch button to break, affecting the AUTO UP/DOWN functionality, or to send a constant incorrect signal that interferes with the desired window motor function. In other words, a switch might always be telling a motor to roll up, and therefore that motor can never "hear" the command to roll down.

Taking things apart for evaluation

If it's the next logical step in evaluation to disassemble the door panel, then be sure to reference the service manual first. While the disassembly procedure tends to be similar for every vehicle, some models have hidden clips or connectors that could create frustration.

Unless the diagnostic logic suggests otherwise, when evaluating a power window, it is best to begin by checking the signals out of the driver's window master switch. Consult the service manual to understand the expected voltage

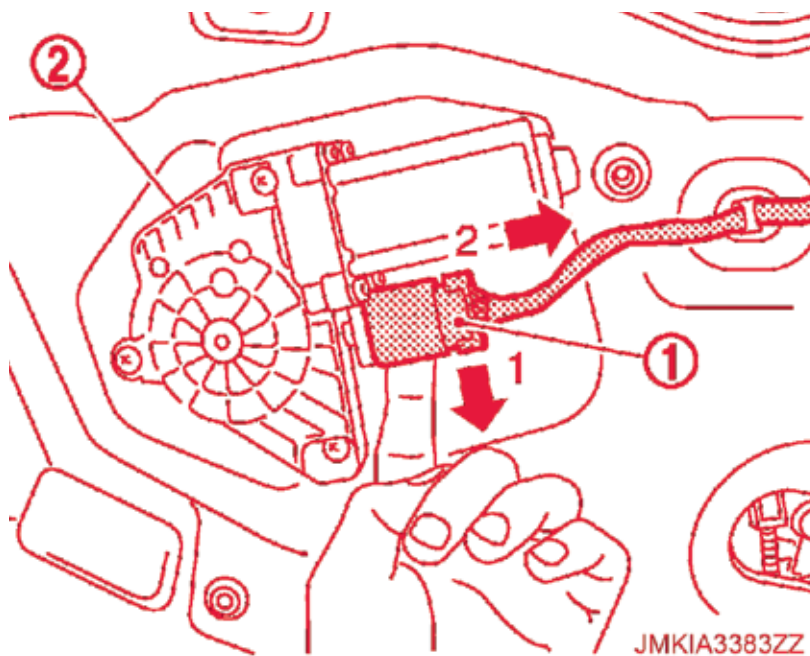

Be aware that this motor's connector has a hidden release latch not immediately visible. Check the service manual before forcing things apart!

signals and connector pins involved. First, you can immediately determine whether the signal arrives from the BCM and the in-between circuit wiring that is called the power window switch serial communication line. Then, you can see whether the signals out of the switch to the motor(s) are as anticipated and within specification.

Testing and confirming failure of window components is not the focus of this article. The December 2016 Nissan TechNews article discusses in-depth test procedures. We will instead focus on electronic window behaviors and initialization after repairs.

Power window motor Encoder

Any Nissan equipped with automatic roll up or down features is also equipped with a window motor that has an on-board Encoder component. The Encoder provides a frequency signal to its respective window switch while the motor is operating. This pulse signal provides both speed and direction of the movement of the window glass.

The Encoder transmits its pulse to the window switch in a manner consistent with motor rotation. The power window switch remembers the current position of the window glass based on motor rotations reported by the Encoder, as well as both the minimum and maximum rotations for fully open and fully closed window positions, respectively.

Power window control systems switch to fail-safe control when malfunction is detected in the Encoder signal. This can occur if a signal that is out of the expected value occurs outside of the upper/lower memorized positions for fully open/closed. When in fail-safe mode, the window control defaults to non-initialized mode, and any automatic functions stop operating.

If the Encoder fails, the window motor will require replacement. It is not serviceable separately.

Other automatic window features

Aside from automatically going up or down when passengers push the switch buttons, many Nissan power window systems have a few other automatic features.

All Nissan windows include a safety “anti-pinch” feature. In the event that an object is pinched while the window is AUTO UP, the increased

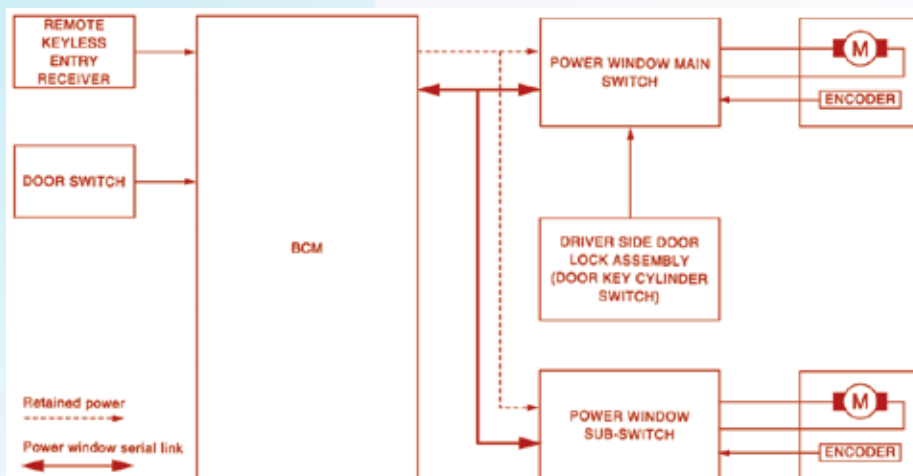

This 370Z coupe's window circuit is abbreviated for quick reference in the service manual.

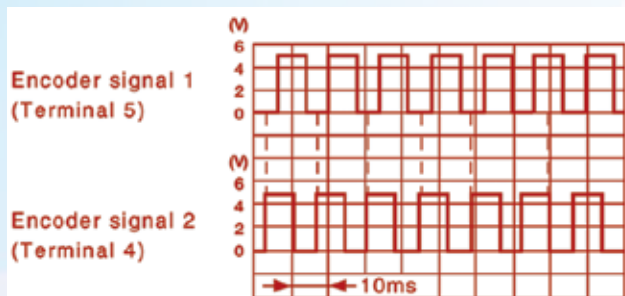

(Starting of terminal 4 is 1/4 pulses earlier)

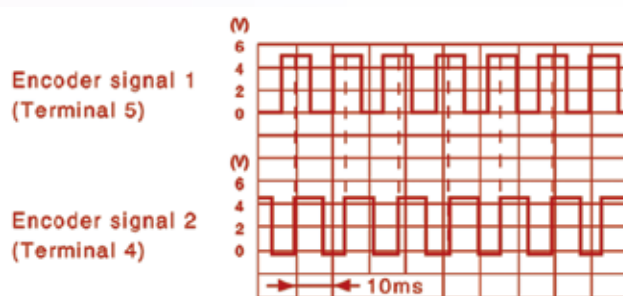

(Starting of terminal 5 is 1/4 pulses earlier)

For this 2013 Altima, the D7 connector has pins to check the Encoder output with an oscilloscope. An erratic Encoder signal will create issues for the automatic windows.

resistance to the motor operation changes the Encoder signal. A change in the Encoder signal alerts the power window switch to halt upward movement, and to roll the window down about six inches. Bear in mind that the window switch ignores this anti-pinch logic at the nearly closed position by design. Likewise, forceful jounces while driving may inadvertently trigger anti-pinch behavior. Never test the anti-pinch functionality with a helper's or your actual hand; try a two-by-four block of wood!

Convertible Nissans like the 350/370Z and the Murano Cabriolet have door frames that do not completely enclose the window glass. Power window control for these designs adjusts the window position automatically during door opening and closing. This is to ensure a proper physical seal between the convertible top and the fully closed door and window.

Upon opening the door, the door switch sends a signal to the BCM. If the current position of the window glass is nearly fully closed as reported via the power window switch serial communication line, the BCM will command the switch to lower the window 10 mm. Upon closing the door, the opposite logic occurs and the window fully closes. Before opening the door, if the window is already open more than 10 mm, no automatic adjustment will take place.

Nissan vehicles equipped with automatic windows can also control them remotely. Even with the ignition turned off, turning and holding a key in the door lock cylinder for at least one full second will close or open all power windows. While holding the key, the lock switch sends a signal to the BCM. The BCM will then command the appropriate power window switch via the power window serial link, which then operates the respective window motor. When the key is released to the neutral position, the windows will stop.

On vehicles equipped with the Intelligent Key, the power windows can be controlled with the remote fob by holding the UNLOCK button. By default, the windows begin to roll down after holding unlock for 3 seconds. If desired, this function can be configured using CONSULT III Plus by navigating to ONE SYSTEM > BCM

> INTELLIGENT KEY > WORK SUPPORT, then selecting the PW DOWN SET mode.

The windows will stop opening after any of the following conditions is met:

- Unlock button held for more than 15 seconds.
- Ignition switch turned ON while still holding unlock.
- Unlock button released.

It is also worth noting that the Intelligent Key remote window opening will not function during retained power mode activation. We will discuss retained power mode more below.

Automatic window function initialization

Window initialization refers to the memorized values inside the power window switch used in accurately determining window glass position. Without proper initialization, NONE of the power window automatic functions noted above will operate.

It is necessary to perform window initialization whenever the following repairs are performed:

- Battery cable(s) are disconnected
- Power window switch cable is disconnected
- Power window regulator and/or motor is removed and replaced
- Window regulator is operated as an independent unit
- Window glass or glass run is replaced
- Power window-related fuse is blown
- Window is partly opened and/or closed repeatedly without ever being fully open/closed

Note that these bullet points are outlined in a Technical Service Bulletin (NTB06-065f) and they offer a general guideline. The service manual will always indicate whenever a repair may coincidentally cause the loss of initialization.

Furthermore, each window switch must be initialized; there is no singular initialization procedure. For repairs like battery cable removal that broadly affect all window switches, be sure to go through and reinitialize each individual window. When in doubt, reinitialize the window one more time before making repair recommendations.

The window initialization procedure

The window initialization procedure can vary from Nissan model to model, so look up the “Additional Service when removing battery negative terminal” in the first pages of the PWC section in the repair manual.

However, the procedure is nearly always identical:

1. Close the door
2. Ignition switch ON
3. Roll the window all the way down, if it is not already
4. Pull the AUTO UP switch until the window is fully closed, and CONTINUE TO HOLD AUTO UP for at least 3 seconds or more.

Some older style window control systems CANNOT be initialized by this easy method! In these instances, the initialization is performed similarly but while holding a reset button on the window motor itself. By reading the service manual first, you can avoid a potential mistake like putting the window panel back on before performing initialization. Also, if repairs in another region might affect window initialization, you can prepare customers to lose these automatic features unless they authorize necessary labor to perform a more challenging initialization.

Retained power mode

As a convenience, Nissan vehicles provide power to the window control system after the car is turned off. This retained power mode is activated immediately after the ignition switch is set to OFF. It lasts until the ignition is switched back on, the driver’s door switch signal changes from CLOSED to OPEN (e.g. driver leaves the car), or after 45 seconds.

Be aware of retained power mode behavior when tracking down a parasitic key-off drain so as not to be confused by the increased draw. If retained power mode malfunctions, the most likely culprits are the door switch or the window switch.

Quality control

There is a word in the medical world for injuries that are caused by the

doctor’s involvement. For mechanics, one of the most common iatrogenic injuries is a failure to reinitialize automatic window systems. It’s easy to lose track of the number of issues that disconnecting the battery might introduce. Knowing that Nissan windows require initialization is an important step in avoiding embarrassing come-back visits.

Whenever faced with a complaint about automatic behavior malfunction, begin with re-initializing the system. Any time you work on a window, for any manner of repair, anticipate needing to perform an initialization afterwards. Following window component replacement, or battery removal, simply test the automatic functions. Know that the AUTO UP / DOWN features may not be designed to work at all with the door open, even when properly initialized.

Don’t forget the sunroof! Many Nissan vehicles are equipped with automatic sunroof controls. While initialization of the sunroof is often a similar process to window initialization, it is one more thing to remember to check. Successfully servicing Nissan vehicles becomes routine once you’ve developed an effective check list for quality control. |



Physically pressing the circled button on this motor is required to initialize its Encoder. Be sure to check the service procedure before putting the door panel back on!