

# STARTUNED®

Information for the Independent Mercedes-Benz Service Professional

June 2018

U.S. \$6.00 | €5.36

Volume 18 | Number 2



INSIDE:

RESTORING CARBON FIBER COMPONENTS  
SCIENCE BEHIND BLUETEC  
FUEL PUMP  
XENTRY AND OBD II

Mercedes-Benz



# Who's Your *Partner* in Success? Mercedes-Benz's

You've chosen your career as an ISP (Independent Service Provider) because you enjoy maintaining, diagnosing, and repairing motor vehicles. One of the most challenging pieces of your business is parts procurement.

Finding the right parts at the right price and being certain they will arrive when promised can be a challenge.

Wouldn't it be nice if there were a way to get the parts you need without the hassle and uncertainty, so you can get back to the important business of actually fixing cars and taking care of your customers?

With the Mercedes-Benz PartsPro wholesale certification program, now there is!

PartsPro is a rigorous program intended to train Mercedes-Benz dealership parts department personnel on how to better take care of you and ultimately your customers. PartsPro certified dealers have elevated their commitment to supporting the independent repair channel, and will provide you with the highest level of customer service. They focus on the things that matter most to you!

## **Convenience...Accuracy... Profitability...Delivery**

A PartsPro dealer has the tools in place to better meet the needs of their esteemed wholesale customers.

For a dealership to achieve PartsPro Certification, parts department personnel must first undergo intensive "customer-centric" training which teaches personnel how to better help YOU.

There's far more to PartsPro than just customer-service training.

The dealership must make specific commitments to provide "Best in Class" service in areas such as logistics, which includes ISP-focused parts availability, regular delivery service, outside sales people to provide you personalized service, as well as a dedicated phone line and "will call" pick up area.

## **Then there's technical help**

On occasion we all need a helping hand. Your PartsPro dealer is there to assist. Whether it means providing diagnostic assistance, information on supplies or special tools, or anything else you may need, your PartsPro dealer is there to assist you in repairing your customers' Mercedes-Benz vehicles and getting them back on the road as fast as possible.

Only those dealerships that meet the stringent certification requirements earn the right to display the "PartsPro" logo. Additionally, they receive ongoing consultation and training to ensure that they are consistently providing the very best support to you, the ISP customer.

We hope you are already receiving industry leading service from your Mercedes-Benz dealer; however, once your dealer is PartsPro Certified, we believe you'll be thrilled with the new "Best in Class" parts-procurement experience!

Of course, you'll continue to have the peace of mind that installing only Genuine Mercedes-Benz parts can provide. |



# STARTUNED®

June 2018

Welcome to *StarTuned*®, the magazine for independent service technicians working on Mercedes-Benz vehicles. Your Mercedes-Benz dealer sponsors *StarTuned*® and provides the information coming your way in each issue.

Mercedes-Benz wants to present the information you need to know to diagnose and repair Mercedes-Benz vehicles accurately, quickly and the first time; text, graphics, on-line and other technical sources combine to make this possible.

Feature articles, derived from approved company sources, focus on being useful and interesting.

Our digest of technical information can help you solve unanticipated problems quickly and expertly.

We want *StarTuned*® to be both helpful and informative, so please let us know just what kinds of features and other diagnostic services you'd like to see in it. We'll continue to bring you selected service bulletins from Mercedes-Benz and articles covering the different systems on these vehicles.

Send your suggestions, questions or comments to us at:

*StarTuned*®

One Mercedes-Benz Drive, Sandy Springs, GA 30328

Phone: +1.770.705.2750

Email: maximillian.brandenburgh@mbusa.com

#### MBUSA Technical Content Advisor

Donald Rotolo  
donald.rotolo@mbusa.com

#### Collision Content Advisor

Benito Cid  
benito.cid@mbusa.com

#### MBUSA Project Team

Stefanie Schweigler  
stefanie.a.schweigler@mbusa.com

Maximillian Brandenburgh  
maximillian.brandenburgh@mbusa.com

#### Group Publisher

Christopher M. Ayers, Jr.  
cayers@automotivedatamedia.com

#### Editorial Director

Bob Freudenberger  
bfreud@automotivedatamedia.com

#### Contributing Editors

Joel Alson, Dave Facciuto,  
Glenn Quagmire, Wayne Riley,  
Frank Walker

#### Automotive Data Media Project Mgr.

Tamra Ayers Banz  
tbanz@automotivedatamedia.com

#### Art Director

Christopher M. Ayers III  
ayersc3@automotivedatamedia.com

## In This Issue

### 4 Do You Understand the Science Behind BlueTEC?

Some European cities are outlawing diesels, but that wouldn't be happening if they were all as clean as those with this Mercedes-Benz technology.

### 10 Restoring the Beauty of Mercedes-Benz Carbon Fiber Components

Carbon fiber reinforced plastic (CFRP) is showing up on more Mercedes-Benz models as the company reduces weight. We provide a few tips on what to look out for when repairing CFRP components.

### 20 Fuel Pump Diagnosis and Replacement

Now that they've gone modular, replacement is an even more expensive proposition than before. Better be real sure.

### 26 XENTRY and OBD II - Go Deep

We will explore the questions surrounding diagnostic equipment, including XENTRY, in an attempt to aid both the business owner and the learning technician.

### 34 Wholesale Team Spotlight: Al DiFranco

Based out of MBNA's Atlanta headquarters, Al heads up the 13-person Parts Assistance Center. DiFranco thrives on being a problem solver. His motto? "We play to win."

Visit us at our website [MBWholesaleParts.com](http://MBWholesaleParts.com) to view a wealth of information on Genuine Mercedes-Benz Parts.

Visit [StarTuned.com](http://StarTuned.com) to access an archive of *StarTuned*® issues, searchable by keyword, vehicle system and publication date.

Mercedes-Benz  
The best or nothing.



*STARTUNED*® is a publication of Mercedes-Benz USA, LLC ("MBUSA"). No part of this magazine may be reproduced without the express written permission of MBUSA. Editorial and Circulation Offices: 134B River Road, Montague, NJ 07827.

**CAUTION:** Vehicle servicing performed by untrained persons could result in serious injury to those persons or others. Information contained in this magazine is intended for use by trained, professional auto repair technicians ONLY. This information is provided to inform these technicians of conditions which may occur in some vehicles or to provide information which could assist them in proper servicing of these vehicles. Properly trained technicians have the equipment, tools, safety instructions, and know-how to perform repairs correctly and safely. If a condition is described, DO NOT assume that a topic covered in these pages automatically applies to your vehicle or that your vehicle has that condition. *STARTUNED*® is a registered trademark of MBUSA.



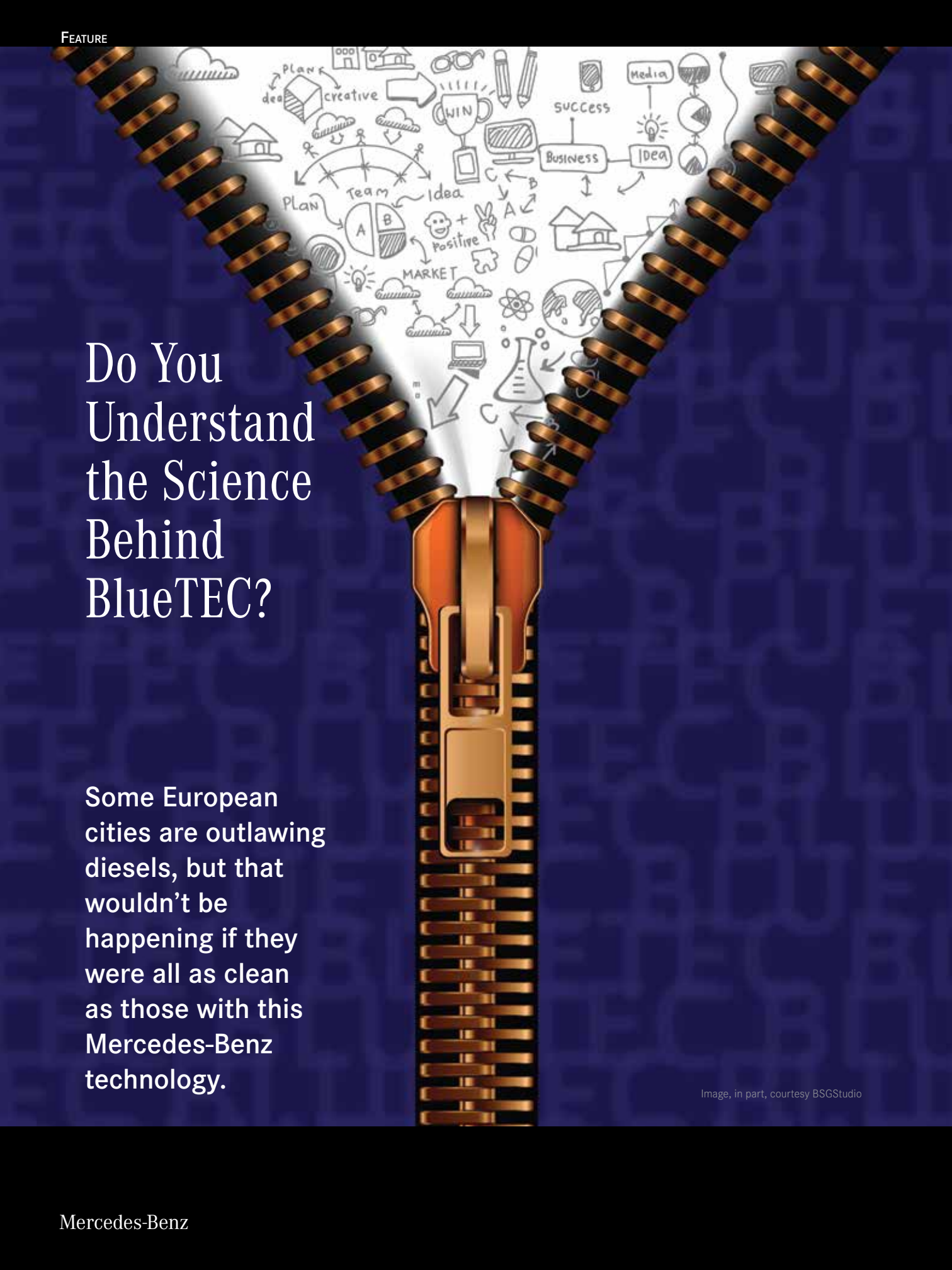

# Do You Understand the Science Behind BlueTEC?

Some European cities are outlawing diesels, but that wouldn't be happening if they were all as clean as those with this Mercedes-Benz technology.

Image, in part, courtesy BSGStudio

Most of the cars you see in your shop have gasoline engines, but with Mercedes-Benz you surely see a fair number of diesels, too. Sure, some are old 123s or 210s, probably needing glow plugs or at least an oil change, but Mercedes-Benz has long been a leader in diesel technology as far back as the 260D (W138) in 1936.

Since then, quite a bit has changed: Instant-heat glow plugs, electronic fuel injection, and low-sulfur fuel. But the biggest change has been the treatment of diesel exhaust emissions.

Back in the Model 124 E-Class era, the Trap Oxidizer was introduced in an effort to cut down on diesel particulate

matter, that black diesel smoke said to be harmful when inhaled. More recently, better Diesel Particulate Filters (DPFs), Selective Catalytic Reduction (SCR) catalysts, and Diesel Exhaust Fluid (DEF) have been introduced to keep diesels in compliance with emissions regulations.

The BlueTEC with AdBlue® system as installed in a vehicle.

- 1. Oxidation catalytic converter
- 2. Diesel Particulate Filter
- 3. AdBlue® metering valve
- 4. SCR catalytic converter
- 5. AdBlue® tank

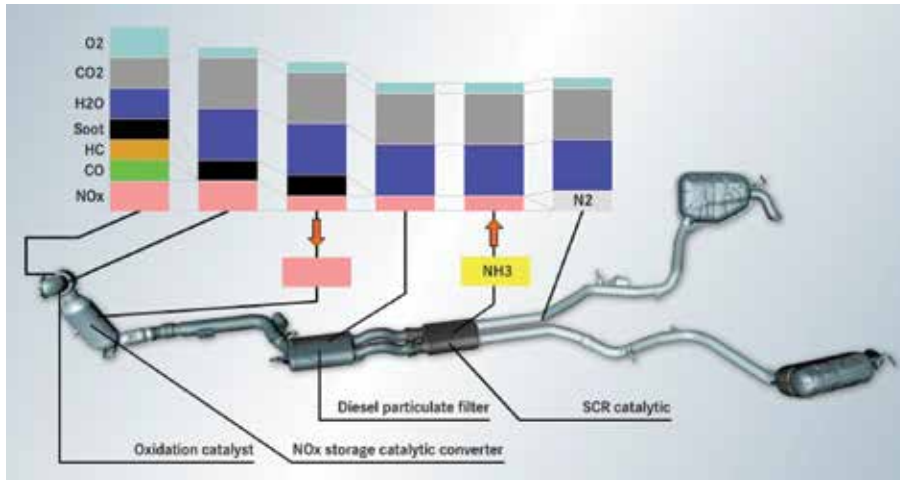
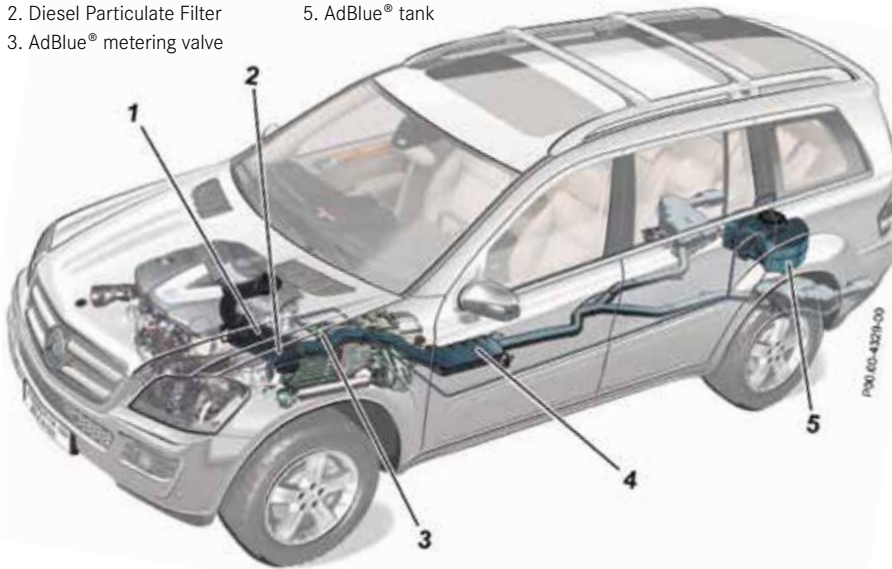

The first phase of the dry BlueTEC system uses four major components: An oxidation catalyst, a NOx storage catalytic converter, a diesel particulate filter and a selective catalytic reduction catalytic converter.

### Dry System

We'll start with the so-called Dry System, which was introduced in the mid 2000s. This system does not use AdBlue® Diesel Exhaust Fluid (DEF), and has been proven to be extraordinarily reliable: For this reason, and because it was only installed for a limited time, we'll only cover it briefly.

The dry system uses several exhaust components to manage the exhaust stream, and it operates in two phases. In the first, the so-called Lean Phase, unburned hydrocarbons and carbon monoxide are converted to carbon dioxide and water in an oxidation catalyst. The



exhaust stream then flows through a nitrogen oxides storage catalytic converter, which, as its name implies, stores oxides of nitrogen (NOx) for later use in the second phase. This stores about 80% of the NOx passing through it.

Diesel particulate matter, or soot, is trapped in the Diesel Particulate Filter (DPF). Similar in function to those old Trap Oxidizers, they literally filter the ultra-

fine soot particles from the exhaust stream. A differential pressure sensor compares the inlet and outlet exhaust pressures, and once the differential pressure gets too high, a Regeneration Phase is started, which burns off the soot, cleaning the filter.

Regeneration occurs by increasing the exhaust temperature, which can be done by post-injection and/or Exhaust Gas Recirculation with intake air throttling. A temperature sensor monitors the exhaust gas temperature. In the case of short trips, the regeneration might happen over several driving cycles. In any case, regeneration is not noticed by the driver.

The rest of the NOx is converted by the Selective Catalytic Reduction (SCR) catalyst, using the ammonia (NH3) that is stored within it, into Nitrogen and water. Note that about 78% of the Earth's atmosphere is Nitrogen, which is not generally recognized as a pollutant. This means the exhaust stream has been converted into Nitrogen, water, Carbon Dioxide (CO2), and Oxygen.

But where did that stored ammonia come from, and what happens when it gets depleted? Good question, and that's where Phase 2 of the dry BlueTEC system comes in.

In this Rich Phase, the engine continues to operate with a lean mixture as before, but additional fuel is injected into the cylinder just before the exhaust valve closes. It simply burns, but without adding to the engine's output energy. Any excess oxygen that was in the exhaust gas is consumed by this extra fuel, also increasing the percentage of unburned hydrocarbons. The relative share

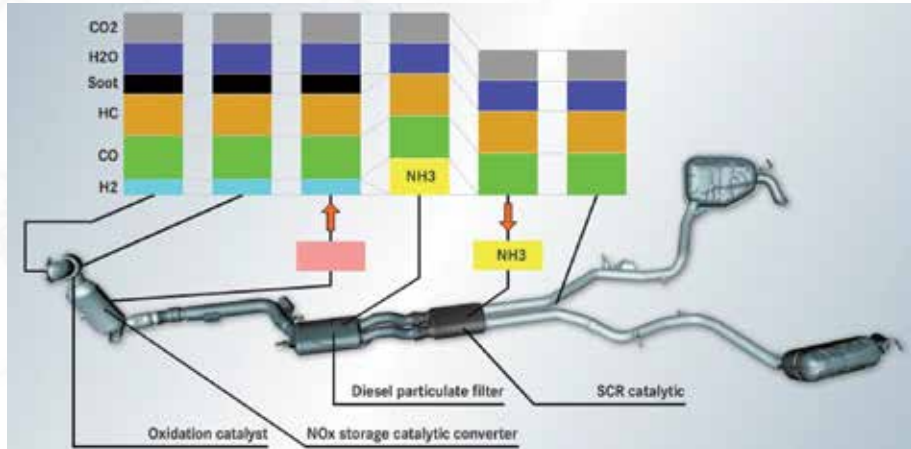

The second phase of the dry BlueTEC system refills the ammonia in the SCR catalyst so the first phase can be repeated. This happens every few minutes during normal driving, and lasts only a few seconds.

of NOx is significantly reduced in the exhaust stream, which still contains water as before.

Since there is no free oxygen, the oxidation catalyst has essentially no effect. The NOx storage catalyst releases NOx into the exhaust stream, which reacts with the water and forms ammonia, NH3. This passes through the DPF and refills the SCR catalyst, allowing the cycle to repeat. The dry system, by definition, does not use external materials such as AdBlue diesel exhaust fluid (DEF), leaving the engine management system to control the entire process.

While these dry systems have been found to be quite trouble-free, when something goes wrong it is most likely to be a sensor that has failed. A distant second is system wiring damage, followed even further by exhaust system failures. In the case of a sensor, it nearly always shows us as a DTC (Diagnostic Trouble Code) easily found using XENTRY, or a generic scan tool.

The regeneration times and intervals are dependent on temperature, and significantly decrease as exhaust temperature rises. The DPF regeneration occurs based on differential pressure, about once every 600 miles, and takes about 10 to 20 minutes to complete. The NOx regeneration happens about every two miles, and takes only a few seconds. Neither would be noticed by the driver.

### Wet System

The BlueTEC 'wet' system, also known as BlueTEC II, is what is installed in current production models, as well as Sprinter vans. Just about every on-road Mercedes-Benz diesel vehicle built for the past several years has this system.



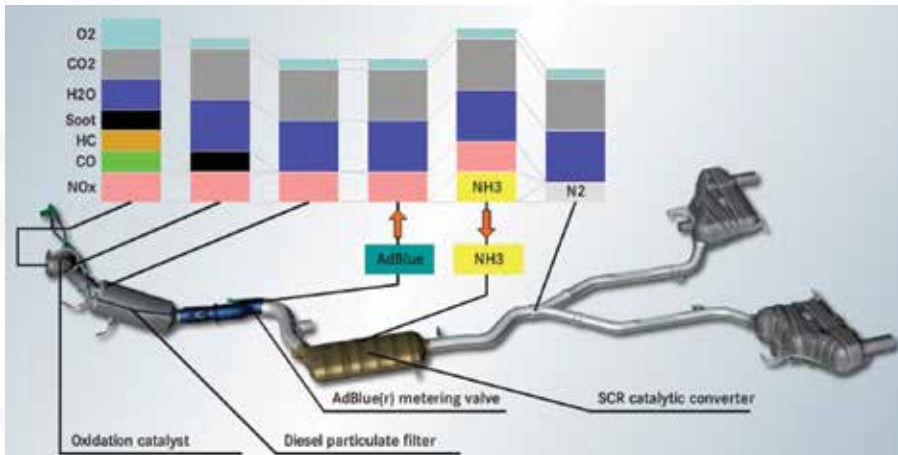

The chemistry of the BlueTEC system with AdBlue (the so-called “wet” system) is very similar to the dry system, but the NOx storage catalyst is not needed since we get the ammonia (NH<sub>3</sub>) from the AdBlue Diesel Exhaust Fluid.



Here’s the AdBlue Control Unit, which is mounted near the AdBlue tank. Not only does it control the feed and injection of AdBlue DEF into the exhaust system, it also controls the heaters used to prevent the AdBlue from freezing at low temperatures. Fresh AdBlue freezes at about 10 deg. F.

Although the dry system’s method of getting some ammonia for the catalytic reaction is brilliant, it’s not as effective as demanded by environmental regulations. To counter this ‘deficiency, the wet system gets its ammonia by injecting precise quantities of AdBlue® Diesel Exhaust Fluid (DEF) into the exhaust system. (Note: AdBlue® is the brand of DEF recommended by Mercedes-Benz, but other quality DEF may also be used). As with the dry system, the first stage is an oxidation catalytic converter mounted near the engine, and in the wet system it performs the same exact task as in the dry system. There is also a Diesel Particulate Filter, again for the same purpose as in the dry system. Further, the wet system also uses an SCR catalytic converter almost identical to the one in a dry system.

The NOx storage catalyst is not needed since we get ammonia from the DEF. Downstream of the Diesel Particulate Filter is the AdBlue Metering valve. This looks and functions a lot like a fuel injector, spraying a precise mist of DEF into the exhaust stream. This is not continuous, but intermittent, since any excess ammonia from each spritz gets stored in the SCR catalytic converter and used just moments later. A mixing

plate, which helps the injected AdBlue distribute evenly and completely in the exhaust gases, is located inside the exhaust pipe, just downstream of the metering valve.

Let’s start with a look at the chemistry of the Diesel Exhaust Fluid. AdBlue is a solution of urea [(NH<sub>2</sub>)<sub>2</sub>CO], meaning it has two NH<sub>2</sub> molecules (a compound known as amidogen) joined together by one carbon and one oxygen atom. This can be converted into ammonia (NH<sub>3</sub>) in either of two ways, known as thermolysis (heat-activated chemical reaction) and hydrolysis (water-activated chemical reaction). These chemical reactions cause the atoms and molecules to recombine into either ammonia plus HNCO (via thermolysis) or ammonia plus CO<sub>2</sub>. While it seems a little complicated, the bottom line is that you don’t really need to know the chemistry to believe that the system actually works.

We are going to describe the system as it was in Model Year 2009, when the system was introduced in the 164 and 251 diesel models. Since then, some of the components have changed slightly, but the overall function of the system remains the same even today.

Although the CDI module has the controlling role in the injection and regeneration cycles, the AdBlue control unit is responsible for handling the AdBlue fluid itself. This includes the actual AdBlue feed and injection, as well as the anti-freeze function (AdBlue DEF freezes at about 10 deg. F.) and the return flow function: AdBlue can be damaged by excessive heat, so after every squirt, the pump is reversed briefly to keep the AdBlue in the injector and the pressure line away from exhaust system

heat. Also, any AdBlue left in the lines at engine stop must be returned to the tank, otherwise it could freeze.

The AdBlue metering valve is operated via a Pulse-Width Modulation (PWM) signal from the AdBlue control unit. During pressure buildup, when the pump just starts pumping, the valve is held open to let any air out of the lines. After the dose of AdBlue is delivered into the exhaust, the valve is again held open briefly during the return flow process to allow the fluid to be pumped back towards the tank. The duration of the reverse pumping action is determined by the CDI control module, based on the exhaust gas temperature as read by the exhaust temperature sensor. The PWM signal allows the valve to deliver varying amounts of AdBlue according to need.

The AdBlue pump operates at a nominal pressure of about 5 bar, which can be adjusted by the AdBlue control module's software. At startup, the pump's current draw is monitored for system diagnosis, setting a DTC for too much or not enough current. If the nominal 5 bar pressure is not reached, as determined by the pressure sensor, a DTC is stored in the CDI control unit fault memory. You'll find the pump, along with the pressure sensor and one of three heaters, attached to the AdBlue tank at the service cover.

The pump must always be fed sufficient liquid to avoid drawing in air, so a second "removal" tank within the main tank is used. It is always kept completely full, by means of a bypass in the delivery module, to avoid all air. It is from the removal tank that all AdBlue is pumped.

The delivery module is heated, as are the tank and the pressure line. The three heaters are controlled by the AdBlue control module. The heaters are enabled at temperatures below about 14 deg. F.

The AdBlue tank is made of plastic, and has temperature and fill level sensors as well as a heating element. The tank is designed such that frozen AdBlue – which can occur if the vehicle is parked outdoors during cold weather – will not cause damage to the tank. The temperature sensor is of the NTC type, which means its

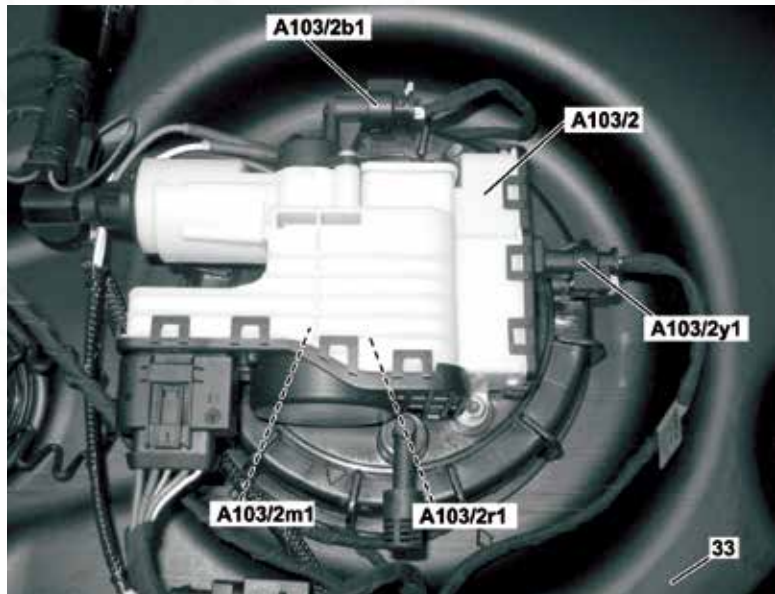

The AdBlue delivery module (A103/2), with pump (A103/2m1), pressure sensor (A103/2b1) and heater (A103/2r1) shown mounted to the service cover of the AdBlue tank.



The AdBlue tank in cutaway. The darker blue area is the removal tank, which is always kept full to avoid introducing air into the pressure system.

resistance decreases with increasing temperature. The fill level sensor is actually three sensors: Full, Reserve Level, and Empty. These are simple electrodes that, when in contact with the AdBlue liquid, show a different resistance between them than when dry (i.e., not immersed in the AdBlue).

## Workshop Tips

In practical terms, the chemistry of the system might not seem important, but an understanding does help when repairs are needed by helping narrow down which sensor must be at fault. We've written about diagnosis before, but as a refresher: If you really know how the system and each component operates, and truly know all the symptoms, then by careful thought a professional



technician can use logic to determine the cause for a fault, and test to verify that conclusion. Of course, the CDI system's DTCs will help narrow things down as well.

So, on to some practical tips. First, if for any reason you empty the AdBlue tank – replacing it, for example – it is



A refill bottle of AdBlue® Diesel Exhaust Fluid (DEF). Similar containers of DEF are widely available at truck stops, as well as in larger drums with an electric pump. This bottle, with its anti-spill valve, is clean and easy to use, thus ideal for your customers.

critical that the removal tank is completely filled before allowing the system to operate. Otherwise, air can be drawn into the system and the nominal 5 bar pressure won't be reached. The main tank must be completely filled before the removal tank is filled via the bypass in the delivery module. Be sure to read the WIS work instructions for this job to get it right.

If your customer needs a refill of AdBlue, normally you can just put more into the tank and be good to go. However, all DEF degrades with heat and time, which can be recognized by a strong odor of ammonia. Mercedes-Benz recommends that the DEF tank be emptied completely every two

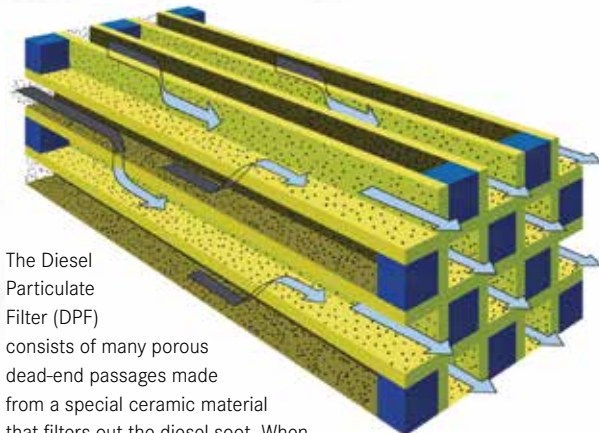

The Diesel Particulate Filter (DPF) consists of many porous dead-end passages made from a special ceramic material that filters out the diesel soot. When the back pressure exceeds a threshold, the regeneration phase starts, effectively combusting the soot and leaving behind only a trace of ash.

years, and refilled with fresh fluid. Of course, a small amount can't be drawn out, but this shouldn't matter.

When handling DEF, read the label and follow all warnings. Use gloves and eye protection without question, but also use shop cloths and other protection to ensure that even tiny splashes of DEF are kept off the vehicle and its components, particularly interior finishes. When AdBlue dries, it crystallizes, forming a white crusty residue that is difficult to remove from soft surfaces such as carpeting. Newer models have the AdBlue filler located outside the vehicle, next to the fuel tank filler opening, while some older models have the DEF filler under a cover in the cargo area.

If your customer admits to having put anything other than DEF into the filler, it is important that the vehicle not be driven. The AdBlue tank needs to be completely emptied of the contaminated fluid by removing it from the vehicle. As we mentioned, follow the WIS instructions for the initial fill of a completely empty tank.

We've found that some owners only use their vehicles for short trips, and the exhaust system doesn't have enough time to get hot enough to regenerate the Diesel Particulate Filter. This is especially noticed in Sprinter vans because of the typical usage patterns of tradesmen. To regenerate the DPF, a decent highway run will go a long way.

If the DPF cannot regenerate properly, excessive soot can bypass it and cause damage to the SCR catalyst. One rule-of-thumb for diagnosis is to examine the tail pipe. If you can wipe with your finger enough soot to actually create a small cake or ball of material, it is likely the SCR catalyst is also affected. A light coating of black soot, which doesn't form a "chunk," but merely dirties your finger, means the SCR catalyst is likely okay. Get the DPF to regenerate and advise your customer to make sure every few hundred miles the vehicle gets a half-hour on the highway.

The BlueTEC wet system is now just about 10 years old, and considered a mature technology. The diagnostic routines in XENTRY and the repair instructions in WIS are pretty solid. It's not a terribly complex system, but the occasional repair and, of course, regular maintenance will keep your customers stopping in from time to time. Armed with an understanding of not only the chemistry, but also the sensors and phases of operation will go a long way toward making each time you touch the system both agreeable and profitable. |

# Facelift

## Restoring the Beauty of Mercedes-Benz Carbon Fiber Components

Carbon fiber reinforced plastic (CFRP) is showing up on more Mercedes-Benz models as the company reduces weight. We provide a few tips on what to look out for when repairing CFRP components.



The carbon fiber rear diffuser on this 2019 AMG GT 4-door Coupe may be repairable, but only if damage is either limited to minor surface scratches, or is hidden out of view on the bottom area of the part.

## Why carbon fiber?

For decades, Mercedes-Benz engineers have been working their magic to extract additional fuel economy from engine and drivetrain improvements. The company is now harvesting further efficiency advances from vehicle weight reduction. Pioneering the use of new composites and alloys, Mercedes-Benz is replacing traditional steel with carbon fiber, aluminum, and other light materials. They offer a superior strength-to-weight ratio while allowing significant weight reduction, often with improvement in structural integrity.

Carbon fiber is five times stronger than steel, twice as rigid, and lighter than aluminum. It is far less vulnerable to corrosion than metal. And, it offers molding flexibility that allows manufacturers the freedom to create components that are both functional and take vehicle design in exciting new directions.

Composites are created from two or more materials, which, when chemically joined, form a product that offers tensile strength that exceeds that of the individual materials. Carbon fiber reinforced plastic (CFRP) is a composite made of strong, lightweight carbon filaments that are embedded in an epoxy resin. The strength of the composite is maximized when you have the proper ratio of resin to fiber, typically between 40% to no more than 50% resin. The carbon fibers give the component greater strength at lower weight than steel or even aluminum.



The interior of the 2019 AMG C 63 coupe includes carbon fiber accents in the dash, steering wheel, center console, and other areas.

## Basic CFRP manufacturing concept

The manufacturing of CFRP is simple in concept, but has very sophisticated variations of formula and process to achieve the performance objectives of different vehicle applications. The simple concept involves three basic steps:

1. Combine carbon fibers and epoxy resin in a mold.  
When creating a CFRP component from scratch, the mold is what gives the piece its shape. Repair is slightly different, and will be discussed later in this article.
2. Using vacuum, extract as much resin as possible out of the mold. Extraction accomplishes three goals. First, it draws liquid resin through the reinforced fiber mesh. This helps ensure that each individual carbon fiber is coated with epoxy resin, which adhesively bonds it to nearby fibers, reinforcing the already high strength of the material. It also removes air and eliminates voids (empty areas) in the mesh. Without air or voids, the cured resin becomes a solid enclosure, called a matrix, which further strengthens the embedded carbon fiber material. The adhesive coating also protects the carbon fiber, which is somewhat brittle, from potential damage during the buildup and curing processes. Second, the vacuum helps draw the CFRP mat into the shape of the mold, or in the case of repair, presses and holds the carbon fiber patch into the cutout area during the curing process. Third, vacuum extraction removes excess resin from the component. This helps create the desired 40/60 ratio of resin to fibers, giving the ideal strength and performance profile to the finished CFRP component.
3. Cure the carbon fiber component by holding the assembly in vacuum over the manufacturer-specified amount of time. In addition to coating the fibers with epoxy resin, removing air, eliminating potential voids in the carbon fiber mesh, and extracting excess resin. The vacuum keeps the fibers in place in the resin as it cures.

The above three-step list is a simplification for explanatory purposes only. Refer to your Mercedes-Benz Workshop





Information System (WIS-net) on the startekinfo.com website for repair information specific to the vehicle and CFRP component on which you are working. You can access an extensive library of documents explaining repair procedures for fiber composites by entering the VIN for a Mercedes-Benz SLR McLaren (model 199) in WIS-net.

## The repair difference

It is important to remember that while the original component is one piece, any repairs depend entirely upon a well-planned and executed adhesive bond to approximate the strength and structural integrity of the original part.

Non-structural CFRP components may be patched in a manner similar to the repair of sheet molded composite (SMC) plastics, if the damage is minor. Grinding out the damaged area with a gradual taper instead of a vertical cut increases the surface area where the original component and the replacement patch will mate. This increases the strength and durability of the repaired part.

The stronger the repair needs to be, the more gentle the taper must be, to create more surface area for the edges that will be bonded.

Mercedes-Benz repair instructions for the CFRP component will typically indicate the desired taper by specifying that you cut in steps so that the opening becomes progressively smaller in diameter as you cut into the composite material. As you rebuild back out, each new layer of replacement carbon fiber mat is slightly wider until you have restored the original thickness of the material. This creates a taper that expands the total mating surface area, and creates a more three-dimensional (top, bottom, and sides) bond. It also helps create a patch that duplicates the thickness and density of the original component, and gives superior resistance to post-repair movement, laterally or vertically, of the patched layers.

## Damage is not always visible on the surface

Collision impact, bending stress, or other damage can significantly reduce the strength of a CFRP component. Unfortunately, CFRP components can suffer impact damage that, while severe, is not visible on the surface. Fibers may be cut, frayed, or separated, but not visible because they are underneath a top layer of uncut fibers. Similarly, horizontal (laminated) layers in the mat can



The cover for the exhaust tailpipe on the AMG GT S is made of carbon fiber. It protects the rear diffuser (lower bumper cover) from high exhaust temperatures and contributes to the aggressive, racing profile of the vehicle's rear end.

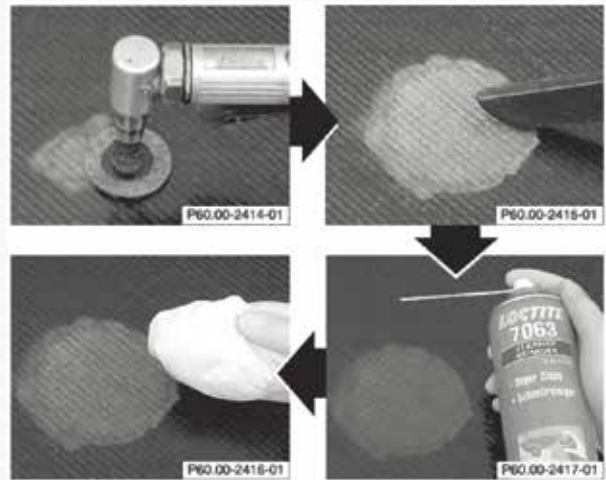

Two things are key when repairing minor surface damage to carbon fiber components. First, do only light sanding, and use sanding disks specified by Mercedes-Benz, to reduce the risk of grinding too deep into the fiber composite layers. Second, clean, clean, clean. Use a wet/dry vacuum to remove sanding dust, then clean the fiber composite surface at least three times with application of fresh degreasing agent each time. Never blow shop air over the surface, as even a tiny amount of oil from your air supply can prevent the epoxy resin from curing properly.

separate, and yet the gap remains invisible because the surface layer was not disturbed.

There may be many thousands of individual filaments in a single carbon fiber, and many fibers in a carbon strand or ribbon that is woven into the CFRP mat. As an electrical cable can no longer carry its rated current capacity after a certain percentage of the individual wires inside its sheathing become broken, a carbon fiber strand or ribbon can no longer support its rated load capacity after a number of its filaments or fibers are broken or separated from each other.

## No repair of structural CFRP components

Any of these types of damage weaken the carbon fiber material. For structural CFRP components such as those that are part of the honeycomb monocoque body of the Mercedes-Benz SLR McLaren supercar, any



## A new line of parts. A new source of revenue.

Introducing Mercedes-Benz StarParts.

Delivering more than just quality, accuracy, and fit, StarParts is an authentic parts line designed for vehicles 5 years and older that is:

- Built for high functionality and fit
- Backed by a one-year warranty\* that includes parts and labor
- Designed to enhance margins and help grow profits for your shop in the long run

To order StarParts, contact your Mercedes-Benz dealership today.

\*To learn more, visit [mbwholesaleparts.com/StarParts](http://mbwholesaleparts.com/StarParts)



Mercedes-Benz  
StarParts





damage beyond superficial surface scratches requires replacement of the complete component. Minor surface scratches may be buffed out and refinished, but anything more extensive cannot be safely repaired. Replacement is mandatory for any structural CFRP components that have suffered weave damage.

### Non-destructive testing

Regardless of whether the component is structural, an exterior panel, or an interior accent, you must determine if there is any significant internal damage before attempting to repair a CFRP part.

A Mercedes-Benz -approved Fiber Composite Tester uses special sensor technology to “see” breaks and other anomalies in subsurface carbon fibers and the resin base in which they are embedded. However, no non-destructive test is guaranteed to detect 100% of damage, especially any that is below the surface. If for any reason you suspect there is subsurface damage to a structural component, even if testing does not confirm it, that part must be replaced.

Non-structural components, including exterior panels and interior accents, may be repaired, depending on the location, type, and extent of the damage.

### Exposed or non-exposed weave?

There are two types of carbon fiber in terms of the visibility of the fiber weave. Each is based on a woven matt of carbon fibers that are embedded in an epoxy resin or other polymer-forming compound.

For one type, called “exposed” weave, the resin is clear or slightly tinted, allowing the weave pattern to be visible through the clearcoat. The other, “non-exposed” type features similar woven matte technology, but receives a solid color topcoat. The weave is not visible under the finish of this non-exposed carbon fiber material.

Because they are woven, both types of carbon fiber require specialized repair for anything beyond minor surface scratches and nicks. Once a composite material’s threads are broken, the individual carbon fibers cannot be re-woven, or “spliced” back together.

You may be able to grind out the damaged area and insert a replacement section of carbon fiber mat, but if it is done on an exposed weave material, a discerning customer may not be happy. Even a really good butt joint created by gluing together two cut edges of an exposed weave carbon

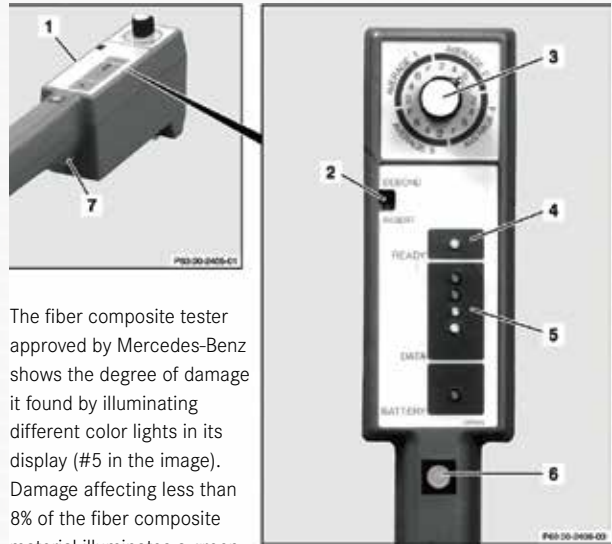

The fiber composite tester approved by Mercedes-Benz shows the degree of damage it found by illuminating different color lights in its display (#5 in the image). Damage affecting less than 8% of the fiber composite material illuminates a green light, and 8% - 16% sets a yellow. The next three levels indicate damage found on up to 40%, 80%, and greater than 80% of the composite material. These result in increasing intensities of red lights, signaling the difference between damage that may be repaired with minimal or moderate amounts of effort, and that which can more efficiently be addressed by replacing the entire component.

fiber panel would likely remind you of a pocket on a patterned shirt; the seam is almost, but not quite invisible.

Damage is slightly less of a problem with carbon fiber that features a non-exposed weave pattern. Working from the underside of the component, you’ll grind out the damaged section and replace it with a new piece of the same weight and weave type.

After sanding to smooth out the surface, applying the solid color topcoat will make the seam edges invisible.

### Dry or wet layup?

There are two basic ways to build CFRP components. Both can be done in a collision repair facility environment, but one is used extensively to construct parts from scratch, while the other is the primary method used to repair damaged CFRP components.

To build a CFRP component from scratch, you add liquid resin to a carbon fiber mat in a mold, press it through the mat and then squeegee or, using vacuum, pull as much resin as possible out of the mold before curing. When done this way, it is called a “wet layup.”

To repair a damaged CFRP part, you grind out the damaged area (or areas), and add to each damage area a new carbon fiber patch that has been pre-impregnated with an epoxy resin. The “pre-preg” mat is placed in the



# THE REFLECTION OF PERFECTION

## ICONIC TO THE FINISH

Whether you're restoring a global icon or repairing one, your customers' automobiles demand the one-of-a-kind, enduring finish that only Glasurit® can provide. Backed by the world's largest chemical company, Glasurit is the leader in automotive refinish paint technology, developing cutting edge, innovative products that are as world-class as the vehicles they enhance. And with a full-range of value-added resources, extensive training and best-in-class color matching technology, choosing our products for your dealership is as smart and easy as applying them. Visit [basrefinish.com/glasurit](http://basrefinish.com/glasurit) to learn more.



A brand of  
**BASF**  
We create chemistry

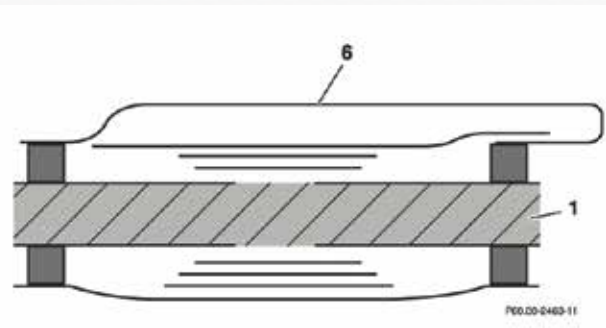

The “dry layup” CFRP repair method uses carbon fiber patches that are pre-impregnated with epoxy resin to repair the damaged area. Vacuum is applied to help infuse the resin through the patch. Layers of perforated film are placed on the top and bottom of the composite material to allow excess resin to be drawn away from the panel (#1 in this image) for disposal after curing. Plastic is taped around the damaged area (#6 in this image) to seal it for application of vacuum. To prevent the plastic from sticking to the patch and causing an uneven distribution of the epoxy resin as the vacuum draws it out, there is a vacuum mat (the white material in this image) that functions as a spacer between the plastic and the patch. A valve is punched through a hole in the plastic, to allow vacuum to be drawn.

cutout area, excess resin is forced out via vacuum, and the piece is cured over a specified number of hours. Done this way, the process is called a “dry layup.”

The dry layup method is easier to use in the field. It wastes less resin, is less messy, and depending on the type and size of the finished component, can be cured without the application of heat.

## Repair strategy depends on extent of damage

Types of carbon fiber material damage that require different repair methods include, but are not limited to:

- Surface damage, one side only
- Holes in the fiber composite, single-layer design
- Holes in fiber composite, sandwich design
- Damage at the edge of a composite panel
- Separated laminated layers
- Separated flange connection between fiber composite panels

Mercedes-Benz offers application-specific repair instructions for each of the above-mentioned types of damage to carbon fiber components. You can find the factory-approved repair procedures by looking up the damaged component in WIS-net by year, make and model of the vehicle.

## No substitutions

The base carbon fiber material can feature any of a variety of different weights, weave patterns, and surface finishes, depending on the intended application. For example, carbon fiber materials are available in different filament densities, or weights, measured in ounces per

unit area (width times length) of fabric. Heavier fabric tends to be stronger, but may also be less flexible for molding into shapes with multiple angles or deeply curved surfaces. Different weave patterns also offer varying combinations of strength, pliability for molding and shaping, and appearance of the finished surface. The net for collision repairers is that you cannot substitute different types of carbon fiber willy-nilly into a repair.

## Temperature and humidity

The epoxy resin must be cured in a specified range of ambient temperature and humidity. If it is not applied and cured within the required ranges, the repair will not achieve its desired strength and durability. The epoxy resin manufacturer will include the required temperature and humidity ranges in their application instructions.

To document that the adhesive was applied correctly, Mercedes-Benz requires its technicians to record the ambient temperature and humidity at the start and through the duration of the curing process.

## Less aggressive sanding for carbon fiber

Refer to the paint manufacturer’s technical data sheets for recommendations on the proper sanding medium. This is critically important when working on carbon fiber components in which the fiber weave is visible in the substrate, such as on the Mercedes-Benz AMG GT. An overly-coarse sanding medium, or too aggressive a sanding application, will result in the clear coat and other top layers being degraded, and some carbon fibers becoming exposed. Once any carbon fibers are torn and exposed, the CFRP component is structurally weakened, and must be repaired or replaced.

## Contaminant avoidance

Carbon fiber surfaces must be contaminant-free in order to allow formation of a strong adhesive bond with whatever component to which they are being joined.

Additionally, avoid using compressed air to dry or cure primers, fillers, or adhesives. Even tiny amounts of oil in the shop's compressed air line can contaminate the CFRP substrate and reduce the strength of an adhesive or other bond. Follow the manufacturer's instructions for the correct process to dry or cure any coating or adhesive on the CF component.

## Carbon fiber explosion risk

Carbon fiber dust is combustible, and can explode when in the presence of a spark. You'll need a dust extraction system, and a separate, enclosed workspace for repairing CF surfaces.

## Pretreatment of bonding surfaces

Surfaces to be glued must be free of contaminants in order to achieve a strong connection between the glue and the parts to be connected. Brush or, if on metal surfaces, grind away dirt, rust, and paint residue.

If bonding aluminum to a carbon fiber component, make cleaning the aluminum one of your last steps before applying the adhesive. Aluminum reacts with air to form a thin skin, called an oxide layer, which will prevent primer, adhesive, or other coatings from developing a long-term bond with the metal surface. An oxide layer begins forming whenever aluminum is exposed to air, so plan to clean and then apply primer, adhesive, or other coatings immediately after grinding away any oxide or other contaminants on aluminum surfaces.

Cleaning requires two steps to ensure a strong bond. First, any grease that has transferred to metal surfaces from tools, compressed air, or even body oils from your fingers must be removed. You can degrease surfaces with carbon tetrachloride or trichlorethylene.

Always follow the procedures recommended by Mercedes-Benz, and by the glue manufacturer. For example, if the glue is a two-part adhesive, use only the bonding agent specified, and adhere to the recommended flash-off time. Follow these guidelines, and your carbon fiber repair will be masterful. |



Made for vehicles 5 years and older, StarParts features a number of the common maintenance items you use the most, including:

- Brake Discs • Cabin Filters • Spark Plugs
- Brake Pads • Oil Filters • Wiper Blades

Backed by a one-year warranty\* that includes parts and labor, StarParts can offer enhanced margins to help grow profits for your shop in the long run.

**To order StarParts, contact your Mercedes-Benz dealership today.**



Mercedes-Benz  
StarParts

## Introducing Mercedes-Benz StarParts

An authentic parts option—at exceptional prices.







**\$966.00**  
MSRP\*  
A 164 490 5236 80



**\$1086.00**  
MSRP\*  
A 251 320 5613 80



**\$1536.00**  
MSRP\*  
A 164 460 0300 80

## Performance. Reliability. Success.

With our competitively priced Genuine Remanufactured Parts, you no longer have to settle for anything less than Mercedes-Benz quality. But that's just part of the story. You see, our AIRMATIC® struts, catalytic converters, turbochargers and steering racks all carry a 24-month, no mileage-restriction warranty. So our parts are not only a great deal. They're a great value. And since they're genuine Mercedes-Benz, you can have confidence they'll last, and so will your relationship with your customers.

### Mercedes-Benz

The best or nothing.

\*MSRP excludes state and local taxes, and freight if applicable. Price excludes core deposit. Price valid as of March 2017. Prices may vary by dealer. See your authorized Mercedes-Benz dealer for additional details or a copy of the Mercedes-Benz parts limited warranty.



**\$415.00**  
MSRP\*

A 000 230 7011 80

Contact an authorized Mercedes-Benz dealer  
or learn more at [www.mbwholesaleparts.com](http://www.mbwholesaleparts.com)



One remanufactured engine pulls the plug on climate-damaging CO<sub>2</sub> and saves 447 days of power for one laptop.



# Fuel Pump Diagnosis and Replacement



Now that they've gone modular, replacement is an even more expensive proposition than before. Better be real sure.



Most of us who have been servicing vehicles for the last several years have become quite familiar with the fuel pump module concept. Mercedes-Benz has been using this for some time, but some of us “seasoned” technicians remember when it wasn’t always so. Fuel pumps were introduced in the 1920s – many cars up through that decade still used gravity to supply the carburetor with gasoline rather than a pump. As technology progressed, gas tanks moved to the back of the vehicle to improve safety. This required the use of a mechanical fuel pump to move the flammable liquid forward and up to the carburetor. When electronic fuel injection arrived, mechanical fuel pumps became inappropriate, so high-pressure electric pumps took over. Mercedes-Benz vehicles at one time had what was called a rail pump mounted in the fuel supply line. This would “suck” gasoline from the tank, pump it up to pressure (which was regulated for the system), then return excess fuel to the tank. To increase efficiency, pumps were soon placed in the tank, operating in much the same way as a submersible well pump.



Here’s a typical fuel pump assembly.

Opposite Page: While fuel filters may look similar, you’ll be frustrated at installation if you got the wrong one.

Electric fuel pumps in late models spin continuously as the engine runs, and over the course of their lifetime will circulate thousands of gallons of gas. Since not all of the fuel that is sent forward is used to run the vehicle, as noted before, the regulator returns the excess to the tank on most systems. One of the drawbacks of this, other than circulating a lot of gasoline, is that the fuel picks up heat from the engine, which is transferred to the fuel pump and reduces its lifespan. In newer “returnless” EFIs, the regulator is part of the fuel pump system and eliminates the need for a return line, thus helping the pump run cooler. When it is combined with variable speed control, the volume of fuel the pump has to move decreases greatly, thus improving its longevity by reducing wear.

### Why do they fail?

Rust, dirt, or debris in the gas tank can kill a fuel pump very quickly. Rust can occur in older steel tanks, while with plastic tanks the material can start to break down after long use. The fuel filter does almost nothing to prevent debris from entering the fuel pump since it is mounted after the pump. Its primary function is to protect the fuel injectors and lines. The only protection for the pump comes from the inlet screen, and this only blocks large debris and cannot keep microscopic particles from wearing a pump out over time. When a pump gets worn, it may become louder and spin at a lower rpm, which draws more current and increases heat, causing starting, drivability, and performance problems. A weak fuel pump may work at idle, but fail when under load. If a pump is really weak, the engine will not start.

### Repair or replace?

It is pretty much a given that we replace electric fuel pumps these days, but that wasn’t always so. To illustrate, the W113 series of cars used one of two types of pumps:

Early (tall) electric fuel pumps were common on late ‘60 Mercedes-Benz cars including the 230, 250, and the early 280SL. The later (short) electric fuel pump was used on W113/W108/W112/W111. These pumps were actually repairable – they could be serviced. M-B once sold a



repair kit containing new brushes and three O-rings, but you will only see these on collectors' cars now.

Replacing a newer-model fuel pump module is fairly straightforward in terms of removal and installation. The location and particulars can be found on XENTRY, or in WIS. It should be noted some modules come as a complete unit including the fuel tank assembly, so the expense involved makes diagnosing the problem properly even more critical. If you find yourself replacing just a pump, be sure the tank is clean. It would be a shame to replace a pump only to have it fail in six months due to dirt or debris in the fuel tank.

## Theory and Design

Let's take a look at how a modern pulse-width-modulated fuel pump module operates in a typical late model Mercedes-Benz. For the purposes of clarity, please note that when referring to a fuel pump module in this article we are speaking of the fuel pump assembly, which is located in the tank. Some Mercedes-Benz models also use a fuel pump control module, which is a separate unit entirely.

Using models 216 and 221 as an example, the fuel supply is controlled and monitored by the ME-SFI control unit (N3/10), and the fuel pump control unit switches the fuel pump on via the discrete signal "EKP run" from the ME-SFI control unit to the fuel pump control unit. The ME-SFI detects the fuel pressure via the fuel pressure sensor (B4/15) and transmits the PWM signal "fuel requirements" representing the current fuel requirements to the fuel pump control unit. This analyzes the PWM signal and actuates the fuel pump appropriately, single phase. The fuel pressure is regulated to be variable from between 4.6 and 5.5 Bar (70 to 82.5 psi), depending on the fuel pressure regulator.

Many Mercedes-Benz cars will have a left and right pump assembly. In those cases, there is a left and right fuel pump control module. The signals, however, mirror each other so, barring a wiring issue, the diagnosis will be identical for left and right.

Input signals consist of:

- Terminal 15
- Circuit 30
- Circuit 31
- Discrete signal "electric fuel pump run" (from ME-SFI control unit)



The pressure sensor is sometimes at fault either reading too high pressure or too low. Scan data should match the actual reading on your mechanical fuel pressure gauge.

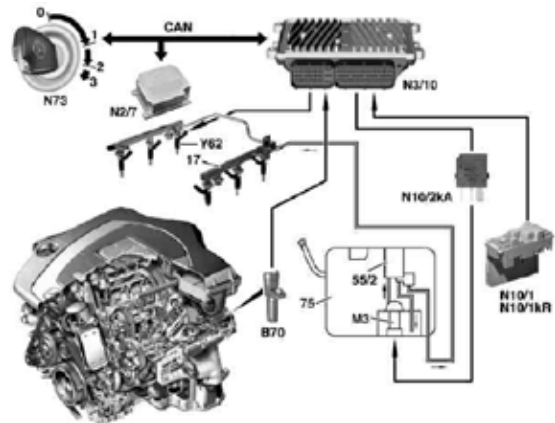

This workshop diagram of fuel system components should keep things in perspective.

- PWM signal "fuel requirements" (from ME-SFI [ME] control unit)

Output signals are:

- Fuel pump - (for model 216, 221 three-phase – 3x+)
- Fuel pump

## Pinpointing the cause

It is important to follow some basic "rules of engagement" here:

- Identify the true underlying cause of the complaint.
- Be sure the problem is not the result of a different trouble elsewhere.
- Look for incorrect version coding.
- Consider overloaded mechanical or electrical components. For example, make sure the battery and charging system are okay, fuel quality is good, etc.
- Think about a possible software error.

Some customer complaints associated with a faulty fuel pump may include, but are not limited to: lack of power, engine cranks, but won't start, engine starts and dies immediately, and gasoline smell after refueling.

Initially, you may find fuel trim or fuel pressure codes. Begin with a short test or quick test of the vehicle, and ensure that the battery and charging system are okay. Obviously, if it's a no-start the latter won't be possible, but good battery voltage is imperative. Hook up your fuel pressure gauge – there should be an accessible Schrader valve test point at the fuel rail in the engine compartment, while older models have a banjo fitting.

The following test steps should be taken:

- Turn the ignition on. At this point, the 12V discrete circuit 15 input is on and the fuel pump control (EKP) signal jumps to approximately 11V for the fuel rail pre-charge function. This is only active on the first ignition cycle after a previous engine start. The set pressure will be based on the engine temperature and other variables. The electric fuel pump running (EKP) signal switches to ground for one second, then back to ignition-on status. The fuel pump demand (PWM) signal will pulse as needed to reach calculated pressure. Observe your fuel pressure gauge to see if it reads within specifications. If you have good pressure, then the fuel pump may not be culprit. We will look at scenarios with no or little fuel pressure first, then discuss what to do if pressure is good, but you still suspect trouble in the pump.



There's almost always a convenient Schrader on the rail for testing actual fuel pressure.

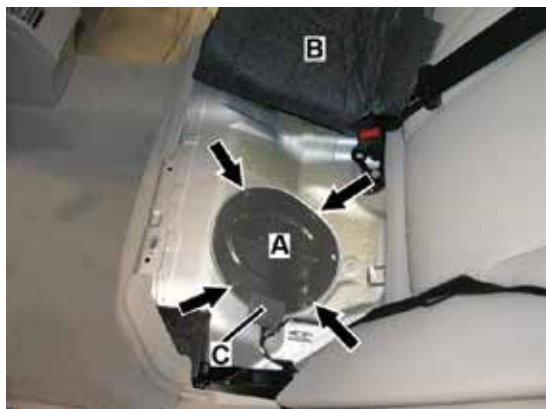

It's a lot better to have access under the back seat than it is to have to drop the tank.

Assuming you have little or no fuel pressure, the next step would be to take a closer look at the fuel control system. This is where it is best to have a XENTRY Star Diagnosis tester, or a factory-compatible scan tool. In your menu screen, you should see something like FSCU (Fuel System Control Unit) actual values. Compare these to the specified values and note any discrepancy. You'll want to pay particular attention to the voltage at the pump, current consumption, and fuel pressure. Also, the requests from terminal 15 and the ME-SFI control module for the pump should be on.

You can now go to activations and command the fuel pump(s) on. The menu might read something like "empty fuel tank" and you will have to choose left or right. You are commanding the pump "on" via the SDS activation. This is currently limited to about 25 seconds and will allow you to compare both pumps' performance. If all your data PIDs are within specifications, but the fuel pressure is low or zero then you will want to actually verify your readings before you condemn the pump.

Locate the fuel pump or pumps, get out your DMM (Digital Multi-Meter), and check for voltage at the pump. Consult the wiring diagram to be sure you are checking the correct pins. A DMM with a lab scope function is ideal for this test. As we mentioned before, this is a pulse-width-modulated system and you will be able to see what is happening more clearly with a lab scope. In any PWM system, the voltage is not regulated (it remains at battery voltage), but the pump is "pulsed" using ground side control. Watching your scope can confirm that you have a good pattern and the voltage has been verified as specified. If all is normal and the pump still is not running, we believe you should do one more test to assure that the new pump has a normal life expectancy: Voltage drop from the positive battery terminal to the positive connection at the pump, and do the equivalent on the ground side. Remember back to your early electrical theory classes about how excessive resistance causes motors to overheat and fail. This is a good time to check the pins very carefully for corrosion and bad connections. A poor connection will cause your new pump to fail prematurely.

## So, you have a poor or no signal to the pump

What's next? Again, XENTRY or an upscale aftermarket scan tool is going to make your diagnosis much easier. You should see on your menu screen an FSCU fault



codes readout. Here is a typical menu readout and possible explanations:

- The fuel pump has a short circuit to ground (pump or wiring to pump is faulty). Check wiring and connections for problems.
- The fuel pump control unit is malfunctioning (FSCU control module is faulty). You pretty much have to rely on your data here, assuming voltages and connection are good.
- Implausible signals from component N3/10 ME-SFI control module (EKP or PWM signals from ME-SFI control module faulty). You could possibly have a can bus issue here. Check the wiring between these components.
- The software is incompatible with the fuel pump control unit (incomplete control module programming). Reprogram the control unit.
- The control unit software is missing or faulty (incomplete control module programming). Reprogram the corresponding control unit.
- The control unit has an internal hardware fault (FSCU control module is faulty). Replace the FSCU control unit.
- The voltage supply is too low (local under voltage at PCM). Check the battery and charging system.
- The voltage supply is too high (local over voltage at ECU). Check the battery and charging system.
- The fuel pump has been switched off (usually due to local over voltage at the ECU). Check the battery and charging system.
- The control unit is overheated (excessive pump current consumption or loose ECU attachment point). The pump may be drawing too much current. Check the wiring and connections, replace the pump, and retest.

### Current ramping

We talked earlier about a scenario that goes something like this: The vehicle is towed in and dropped off at your facility with an “engine cranks – no start” concern. You turn the key and the vehicle starts right up, it runs fine, and you drive it into your bay. We’ve all experienced this at one time or another, but how to address it? The customer had a valid concern, but you just weren’t able to verify it. You will want to approach your diagnosis the same as if it still were a no-start. Start with your scan tool and see if there are any related fuel pump codes. Even though the pump is running at this point it doesn’t necessarily mean it is working to its full potential. Scan data to pay attention to will be:

- Voltage at component M3 fuel pump
- Current consumption of component M3
- Fuel pressure

This is where it is a good idea to conduct a current ramp test. You will need a low-amp probe and a lab scope to perform this test. Use the 20A setting at 10ms. What you are looking for is some sort of sign in the pattern that indicates the pump is struggling to operate. Remember, you are working on a PWM system and the humps frequency will vary, so don’t be as concerned with that as the amount of current the pump is drawing.

### Fuel smell

We mentioned plastic tanks and components deteriorating over time. All fuel pump assemblies are plastic and you may get some complaints of a fuel smell in the vehicle particularly when filling the tank. There is a recall of some S-Class models with stress fractures in the pump and filter mounting flanges that can cause leakage and pressure drops. Consult the TSBs for the vehicle and perform a visual inspection of the pump and filter flanges.

### Quality control

Here are some steps to assure that your repairs have solved the customer’s concern and keep your come-back ratio down. Be sure to perform a version coding if necessary when replacing parts. Road test and perform a final short test on the vehicle for pending issues. Eliminate any effects from the repair – learn-in any new values etc.

We’ll bet that all of us have been brought a no-start vehicle with no fuel pressure – and no fuel in the tank. Embarrassing for the customer, but more embarrassing for you if you miss it. And don’t forget the fuse panel. Sometimes a simple blown fuse is the culprit, but now you will be tasked with finding out why that fuse blew. Remember to keep it simple! |

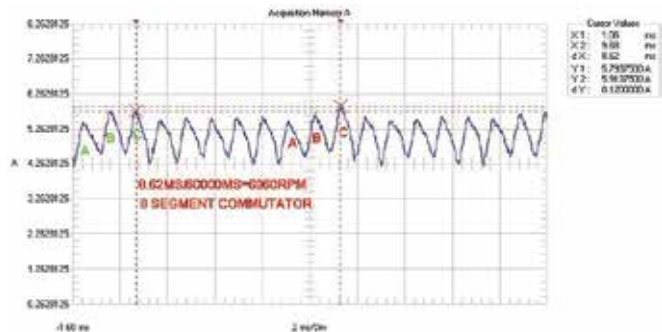

The current ramping waveform.

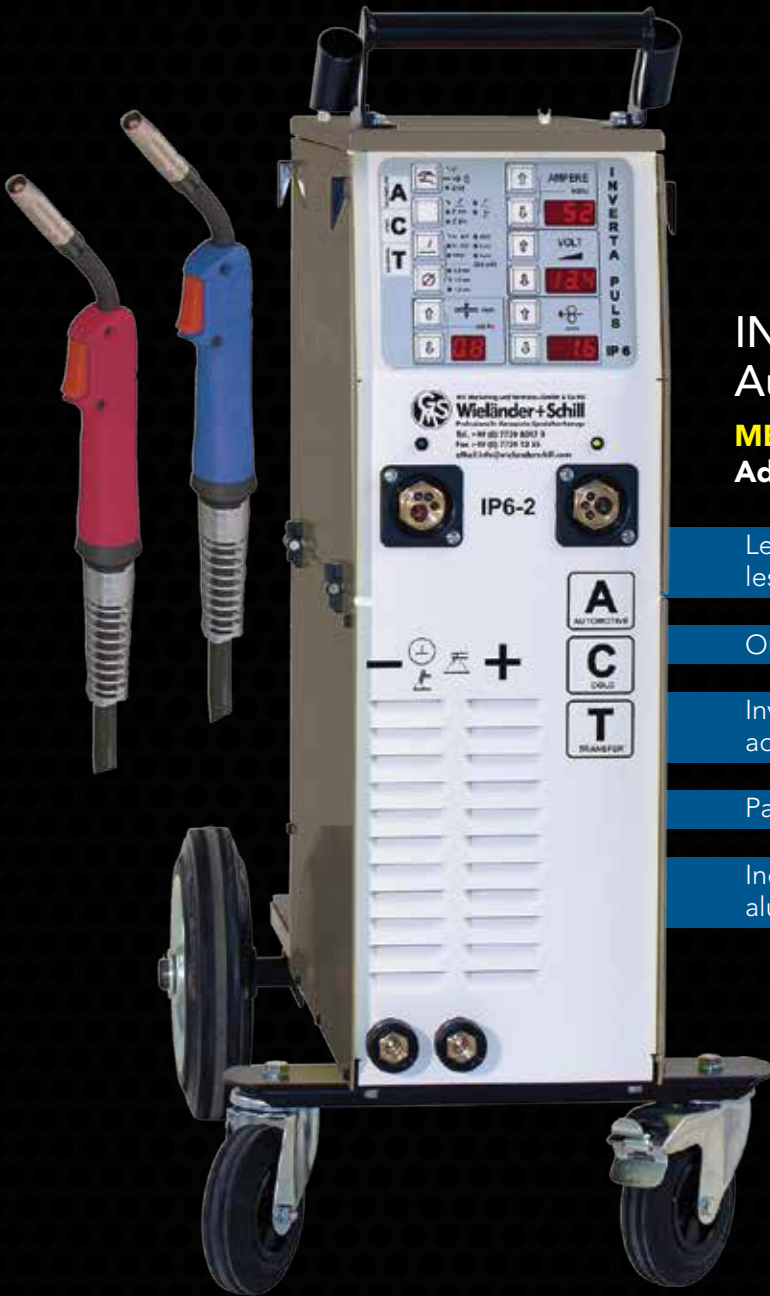

## INVERTA-PULS IP6-2 Automotive Cold Transfer

**MERCEDES-BENZ-Approved** for Aluminum,  
Advanced Steels, and MIG Brazing

Less heat input, less material distortion,  
less reworking

Outstanding thin sheet welding

Inverter-based pulsed MIG – for welding  
advanced materials

Part Number: WS-332007

Includes two torches, plus one each steel and  
aluminum wire feed rolls

## ROLL OUT 2000

10-minute windshield removal

One tool, all cars

Remove a Windshield in 8-10 Minutes

No heat, batteries, or fuel needed

No paint scratches, no damage to windshield frame

Only one technician needed

Roll Out Part Number: WS-842010



Phone: 732-495-7900

e-mail: [info@rae1.com](mailto:info@rae1.com)

[www.raeservice.com](http://www.raeservice.com)

Like us on Facebook at: [facebook.com/ReliableAutomotiveEquipment](https://facebook.com/ReliableAutomotiveEquipment)



# XENTRY

and OBD II  
Go Deep

*The roots of education are  
bitter, but the fruit is sweet.*

-Aristotle

Image, in part, courtesy NASA



Whenever diagnostic sessions are not progressing well, the choices confronting shop owners and technicians can be daunting. Sometimes that vehicle may appear to “have a mind of its own,” but you won’t be able to read that mind without the right tools.

Here, we will explore the questions surrounding diagnostic equipment, including XENTRY, in an attempt to aid both the business owner and the learning technician. We’ll also look at how the DLC (Diagnostic Link Connector) is evolving at a rapid rate, and why good comprehension of the technology present in Mercedes-Benz vehicles is important.

## OBD II and the DLC

In 1996, OBD II was made mandatory for all vehicles sold in the U.S. (in actuality, for all of North America). That also meant that the modern OBD II connection (DLC) became standard. What is not standard are the “proprietary” connections to subsystems. OBD II was designed for engine and transmission diagnostics for the dealer or non-dealer technician, and it offers an array of “modes” that are related to emissions, testing, and diagnosis.

### OBD II pinout and terminal assignments

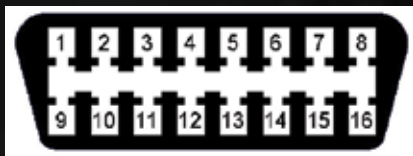

DLC Port

- |                                          |                                           |
|------------------------------------------|-------------------------------------------|
| 1. Manufacturer specific                 | 10. Bus negative Line of SAE-J1850        |
| 2. Bus positive Line of SAE-J1850        | 11. Manufacturer specific                 |
| 3. Manufacturer specific                 | 12. Manufacturer specific                 |
| 4. Chassis ground                        | 13. Manufacturer specific                 |
| 5. Signal ground                         | 14. CAN low (ISO 15765-4 and SAE-J2234)   |
| 6. CAN high (ISO 15765-4 and SAE-J2234)  | 15. L line for ISO 9141-2 and ISO 14230-4 |
| 7. K line for ISO 9141-2 and ISO 14230-4 | 16. Battery voltage at all times          |
| 8. Manufacturer specific                 |                                           |
| 9. Manufacturer specific                 |                                           |

As the OBD II protocol matured, so did the array of modes and data that was accessed for profoundly complex engine management systems. Manufacturers are required to have their protocols available at the DLC. Those protocols will include CAN, VPW, PWM, and 9141-2 with ISO 14230-4. All North American vehicles will have access to one or more protocols via OBD II. There are, however, specific pins (terminals) at the DLC that are used by the manufacturer for its own purposes. OBD II has no access to those pins.

Well-designed modern OBD II devices can access far more data than the scan tools of the past, but that all depends on the capability of the suppliers and software developers to mathematically calculate the PIDS for display on the scan tool if those PIDS are mandated and available via the carmaker. Current OBD II tools have access to diagnostic data via high-speed CAN.

Even though a modern OBD II scan tool can access the CAN structure, it will have minimal access to the engine and transmission electronics network on any particular make, Mercedes-Benz included. The data will be only what’s required by regulations. There are many forms of OBD II scan tools, the most common being the ELM327 or ELM329 comprising a programmed microcontroller. The development of standard OBD II will continue to move forward, but access to Driver Assist Systems may not be possible.

## Multiplexers and aftermarket equipment

There is an array of aftermarket tools that claim “complete access” to the vehicle diagnostic port including all internal networks and sub-networks. Unlike OBD II, these types of multiplexers may be able to access the complete network structure if the tool software and firmware is current and correct. Added as well is access and permissions to all installed networks and corresponding sub-networks. Complete and up-to-date access should include more than one CAN network attached to a gateway that supports multiple networks and sub-networks.



These tools, however, have inherited issues with accuracy, guided tests, and poor/insufficient documentation. One common issue is bi-directional control with future support. Another common problem is the association of workshop information with clear parts illustrations. A third typical issue is the association of data provided among controllers and the Central Gateway (CGW). The newest problem with these tools is access to the Ethernet structure. Welcome to DoIP.

### XENTRY articles

Refer to these previous articles that have been published about XENTRY in *StarTuned*. They explain XENTRY performance and how to perform the tasks required within a professional workshop environment. They're all informative:

- Newest Features of Versatile XENTRY Diagnostic System (March, 2016)
- The Intelligent Servo Module (December, 2016)
- Why You Need XENTRY (June, 2017 as a sidebar to Using WIS Efficiently)
- Control Unit Programming Now! (December, 2017)

### XENTRY at work on communication errors

The copy, captions, and images throughout this article illustrate the complexity of the diagnosis of a mysterious real-world case concerning a 2011 ML 350 BlueTec. The customer's basic complaint was a no-start, which only happened once. But there was more going on: all warning lamps were ON, the warning chime was sounding continuously, and the wipers turned on intermittently. Also, Direct Select was not operating and no selection was showing on the display. Finally, the no-start repeated.

Our diagnostic preparations included a "circle check" of the entire vehicle and testing of both batteries. We made sure our XENTRY was updated, attached a clean and stable power supply, and

turned off all electrical consumers. Then, we used the VIN tab to identify the correct model, performed a complete Quick Scan, and saved the primary results.

The following lists all the controllers found "after the fact" with a repair and rescan. This list identifies the controllers that were not communicating with XENTRY and were not in the Quick Scan list:

- ISM – Intelligent Servo Module
- IRS-HLA – Outer left rear intelligent radar sensor system
- IRS-HRA – Outer right rear intelligent radar sensor system
- XALWA-R – Xenon headlamp, right
- XALWA-L – Xenon headlamp, left

Control Unit	MB number	Result
ECU		
CGW - Central gateway	1646403683	✓
EZS - Electronic ignition switch	1649051500	- ✓ -
KG - Keyless Go	1649010100	- ✓ -
Common Rail Diesel Injection		- ! -
SCR - Selective Catalytic Reduction		- ! -
Transmission		- ! -
ESP - Electronic stability program		- ! -
AB - Airbag		- ! -
SAM-F - Signal acquisition and actuation module front	1645456716	[ ! ]
REAR SAM - Rear signal acquisition and actuation module	1645457016	[ ! ]
OCP - Overhead control panel	1648703126	[ ! ]
HBF (Rear control panel) - Rear control field	1648209489	- ✓ -
UCP - Upper control panel	1648709910	- ✓ -
IC - Instrument cluster	1645402048	- F - [ ! ]
ASSYST Active Service System	1645403662	- F -
SCM (MRM) - Steering column module		- ! -
PTS - Parktronic system	1645453710	[ ! ]
COMAND or AUDIO	1649012600	- ✓ -
SOUND - Sound system	1729012100	- ✓ -
UCI - Media Interface	2049015602	- ✓ -
SDAR - Satellite radio	1718701189	- ✓ -
DCIM-FL - Door control module front left	1648701526	- ✓ -
DCIM-FR - Door control module front right	1648701626	- ✓ -
REDC - Rear-end door closing control module	1648209526	- ✓ -
ESA driver - Electric seat adjustment driver (with memory)	2118704785	- ✓ -
ESA passenger - Electric seat adjustment passenger	2118704885	- ✓ -
HS - Seat heater	2118703885	- ✓ -
AAC - Automatic air conditioning	2518206489	- ✓ -
Battery voltage	13.39 V	

With a complete XENTRY Quick Scan, all current errors and controllers found present will be on a single screen. Save those messages from XENTRY. This is a combination of two images at the time of the no-start. Notice the controllers: Common Rail Diesel Injection, SCR-Selective Catalytic Reduction, Transmission, ESP (Electronic Stability Program), and AB-Airbag. There's a recorded disruption within the network when the subsequent diagnostic scans change over time. A deep analysis also indicates that multiple controllers are off-line.

The Quick Scan tells you what controllers are active/recognized on the network with corresponding faults. The primary list of controllers in the image is complete and it appears that there are other controllers not communicating with XENTRY. The count so far is 28 controllers, and six of them have the - ! - in the results column.

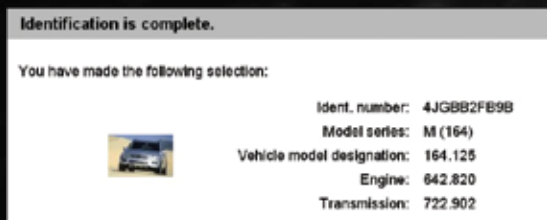

Using the VIN tab identifies the correct model.

- RevETR-LF – Left front reversible emergency tensioning retractor
- RevETR-RF – Right front reversible emergency tensioning retractor
- ASSYST PLUS – Plus Active Service System

There are eight controllers off-line and the total count is 36 for this model.

Vehicle	164.125	Control unit	CGW
Read coding and change if necessary.			
	Coding		
Keyless Go	PRESENT		
Interior motion sensor	NOT PRESENT		
ATA interior motion / towing sensor	PRESENT		
Trailer recognition	NOT PRESENT		
Parktronic system or Parkpilot	PRESENT		
Electronic drive unit	NOT FITTED		
Tire pressure monitor	NOT PRESENT		
Automatic engine start/stop	NOT FITTED		
Blind spot assist	PRESENT		
Power steering	Hydraulic power steering		
Electric suction fan	ACTIVE ( Standard )		
Blind spot assist	PRESENT		
Steering version	Standard / Speed-sensitive power steering		
Air suspension	NOT PRESENT		
Transfer case	NOT PRESENT		
Differential lock ( FRONT )	NOT PRESENT		
Differential lock ( CENTER )	NOT PRESENT		
Differential lock ( REAR )	NOT PRESENT		

Intelligent Servo Module, Blind Spot Assist and Xenon headlamps are controllers that were never seen in any of the previous scans, images, or saved documents.

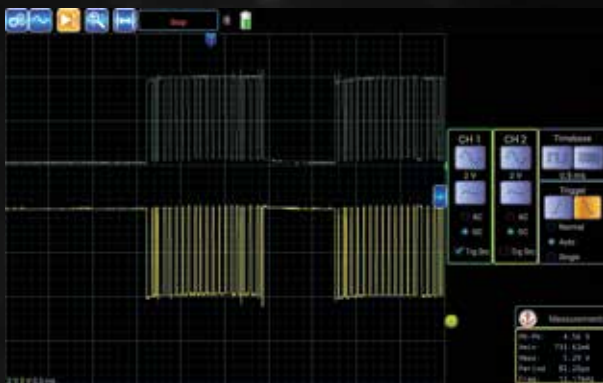

The oscilloscope used for this simple test is Bluetooth-connected to an Android-based tablet. The probes used are 10:1 switched and were set to the 10x position.

The image “CAN B expected” was captured with KOEO while connected between the CGW Gateway and the CAN B connector station. Wire colors are: Brown (CAN L) and Brown/Red (CAN H). The “CAN B expected” image indicates a normal and standard view of a CAN message. This is to be expected and follows the voltage rules on this network. Capture/Save the screen and leave the settings on the scope in the same state.

Move the probes to the CAN C connector station and connect to the wires coming from the CGW Gateway. Wire colors are Green (CAN L) and Green/White (CAN H).

**HINT:** If there is no M-B number, the controller was never fully interrogated/accessed.

Using the print feature of XENTRY, save the entire initial scan and read the complete document. The investigation begins with the primary scan and all of the associated faults recorded within the first session.

An attempt to “reset/restart” the controllers having communication errors may fail, but maintaining a record for one attempt provides a guide for searching for interrupted or corrupt controllers. Record that session as well and keep the sessions separate. A safe procedure to reset/restart the network is to disconnect XENTRY and the power supply, have the driver window open, and remove the key. Disconnect the negative battery cable and wait 30 minutes. Reconnect the power supply and XENTRY, try the Quick Scan again, and record that attempt.

## XENTRY guides go deep

One way of knowing if your theory is correct is by requesting the CGW coding data, or requesting an Interior CAN check. Access the information document on paper, or by way of a PDF (Adobe), and use the search feature.

**Hint:** The CGW is factory-programmed with all of the installed equipment when this model was built. Request a print and pay attention to what is not installed or not active. When reading the document, the CGW will be known as ECU\_ZGW. This model has this equipment available that is of interest:

- ECU\_ZGW\_DEF\_SA: Automatik-Getriebe (C423)@vorhanden
- ECU\_ZGW\_DEF\_SA: Blind Spot Monitoring@available
- ECU\_ZGW\_DEF\_CAN-C: Blind Spot Monitoring@available
- ECU\_ZGW\_DEF\_SA: Xenonlicht (C612)@vorhanden

If a restart is possible, using XENTRY will record all available/active controllers, and this new printout was nine pages long. Most of the faults produced CAN message errors between the controllers such as Engine, Transmission, ABS, SCR, Instruments, Airbag etc. In other words, those controllers would complain about each other’s’ CAN messages. The remainder of the installed controllers recorded faults, including the “undervoltage supply” fault.



The first restart/saved scan produced 113 faults! Note that the CGW had no faults and does not mean a defect is present.

The controllers that have no recorded faults are:

- (1) ASSYST PLUS - PLUS Active Service System
- (2) COMAND or AUDIO
- (3) UCI - Media Interface
- (4) SDAR - Satellite radio
- (5) HS - Seat heater

With the recording of multiple faults within multiple controllers, it can be assumed that there may be messages not recognized at the CGW. With XENTRY, the CGW controller can indicate what controllers are present and active.

### The path toward the deep

To find out what messages are missing or corrupt:

- (1) At the Quick Test screen, choose CGW
- (2) Control Unit Adaptations
- (3) Read coding and change if necessary
- (4) Vehicle-specific data

Scroll through the entire open window and notice all of the equipment with messages attached under the Coding column. Blind Spot Assist and Xenon headlamps are PRESENT. With XENTRY, the entire CGW controller configuration can be viewed along with a list of installed equipment. Requesting a print offers detailed information.

With a Gateway that has no errors, what do the messages look like? Note that one function of the gateway is to pass information to the intended network(s).

**Hint:** Go back and notice Automatik-Getriebe (C423)@ vorhanden, CAN-C: Blind Spot Monitoring@available with the XENON headlamp system. Keep in mind other non-communicating controllers.

### Using WIS to go even deeper

Using the Workshop Information System with XENTRY offers the precise information via VIN and will aid in further diagnosis, functions, tests, and diagrams with proper re-fitment illustrations. WIS and XENTRY are “joined at the hip.”

Two networks are of interest:

- CAN C = Engine CAN and known as “chassis CAN.”
- CAN B = Interior CAN and known as” body CAN.”

A good place to start especially if you’re new to XENTRY, is to press F6 (Help) and go to Networking topology (CAN, telematics) CAN networking Interior compartment. Look for and view the Arrangement diagram and x30/19 Voltage distributor (CAN C) Right Front.

For the following test, gather the correct schematics and follow the wire positions for CAN B and CAN C. The accompanying image is expected with KOEO while connected between the CGW and the CAN B connector station.

Leave the oscilloscope connected ,cycle the ignition key once, return to XENTRY, and reattach it to the DLC. Perform a Quick Scan and there will be faults generated from all previous tests. Clear all fault recordings generated by XENTRY. Follow the clear-faults procedure

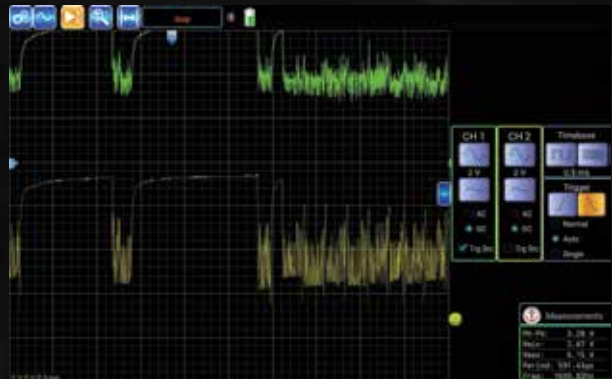

This is not the expected image and is part of the theory as to why there is a disturbance within the network and partial loss of communication. Capture/Save this and other screen images of importance. With the scope operating and leaving the probes connected, remove one connector at a time. If nothing changes, reconnect that connector and move on to the next one while viewing the oscilloscope image. If the image normalizes, leave the connection off and mark/band it for later tests.

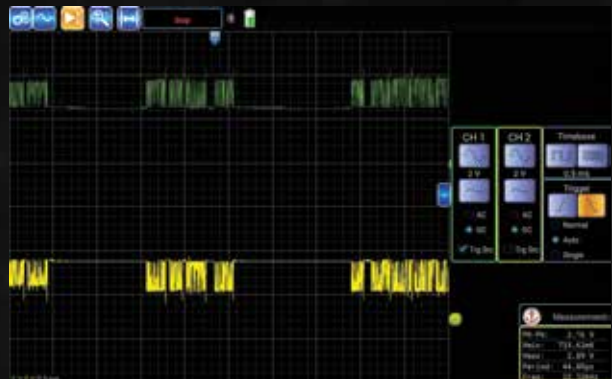

This image “CAN C expected image“ is what should be predictable following the voltage rules for this particular CAN system. What is not known currently is who the “bad actor” is after that connector was removed from the network station.

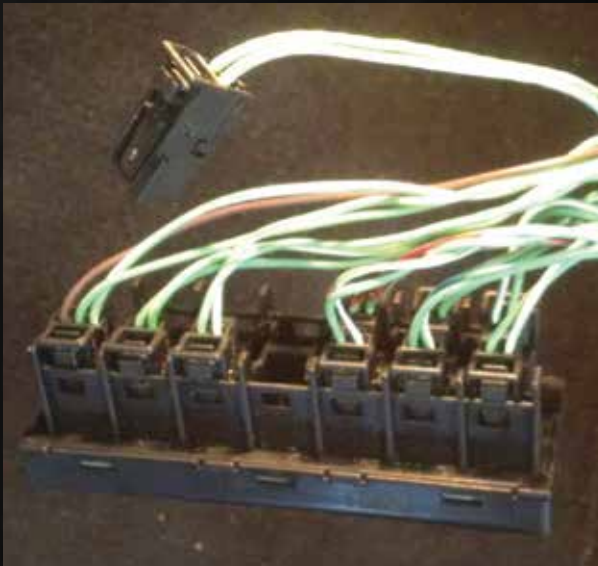

The defective controller unplugged.

Vehicle	164.125	Control unit
Current quick test.		
Filter status: All control units		
ECU	ME number	Result
CGW - Central gateway	1645403662	✓
EZS - Electronic ignition switch	1646051500	✓
KG - Keyless Go	1646010100	✓
CDI 6B/HSE/6 - Common Rail Diesel Injection	6420010400	✓
SCR - Selective Catalytic Reduction	1644460054	✓
ETC - Electronic transmission control	0034460310	✓
ISM - Intelligent servo module	0054401610	✓
IRS-HRA - Outer right rear intelligent radar sensor system	0065428118	- F - [!]
ESP - Electronic stability program	1645458232	✓
AB - Airbag	1646205565	✓
SAMF - Signal acquisition and actuation module front	1645456716	✓
REAR SAM - Rear signal acquisition and actuation module	1645457016	✓
XALWA-R - Xenon headlamp, right	1646005100	✓
XALWA-L - Xenon headlamp, left	1646005100	✓
DCP - Overhead control panel	1648703126	✓
HBF (Rear control panel) - Rear control left	1646209489	✓
UCP - Upper control panel	1648709910	✓
RevETR-LF - Left front reversible emergency tensioning retractor	1646012600	✓
RevETR-RF - Right front reversible emergency tensioning retractor	1646012600	✓
IC - Instrument cluster	1645402048	✓
ASSYST Active Service System	1645403662	✓
ASSYST PLUS - PLUS Active Service System	1645403662	✓
SCM (SRM) - Steering column module	1645456716	✓
PTS - Parktronic system	1645453716	✓
COMMAND or AUDIO	1646012600	✓
SOUND - Sound system	1729012100	✓
UCI - Media interface	2040016902	✓
SDAR - Satellite radio	1718701189	✓
DCMFL - Door control module front left	1648701526	✓
DCMFR - Door control module front right	1648701626	✓
REDC - Rear-end door closing control module	1648209526	✓
ESA driver - Electric seat adjustment driver (with memory)	2118704766	✓
ESA passenger - Electric seat adjustment passenger	2118704666	✓
HS - Seat heater	2118703666	✓
A/C - Automatic air conditioning	2518206489	✓
Battery voltage	13.39 V	

The count now is 35 controllers with IRS-HLA - Outer left rear intelligent radar sensor system missing within the scan. Follow the fault for IRS-HRA and note the remaining fault. In total, this model will have 36 controllers active.

Vehicle	164.125	Control unit	IRS-HRA
Event memory			
Code	Text	No.	Status
552002	No CAN message received from component B2974 (Left rear bumper intelligent radar sensor)	0	Event CURRENT and STORED

Perform a road test with the correct repairs and proper components. Using XENTRY for that last test, ensure no more faults are recorded.

according to the prompts on the screen. XENTRY will now produce an updated list of controllers and any faults that have returned. Save this updated scan and read it in its entirety. Search for the differences and communication status for all installed controllers.

This case produced five printed pages with no errors. With the information provided earlier, the “bad actor” is now evident.

The resulting scan found two controllers missing:

- IRS-HRA - Outer right rear intelligent radar sensor system
- IRS-HLA - Outer left rear intelligent radar sensor system

Test this again with the oscilloscope by reconnecting the harness to the station. The oscilloscope will react immediately and chances are that the customer’s complaints returned.

The test can be proved with some accuracy with XENTRY identifying non-communicating controllers in the network.

Disconnect the harness at the station again and look for a normal oscilloscope pattern. Inspect both Blind Spot Monitoring modules and harness connections of the vehicle.

Choose either left or right, but disconnect one side and confirm with the oscilloscope. If the correct/defective module is disconnected, the oscilloscope reading the CAN pattern returns to normal and XENTRY will produce a final outcome. On the last Quick Scan, one controller is not recognized because it has been disconnected, but the network is back to normal.

There will be a warning within the instrument cluster that Blind Spot Monitoring will not be available. All other functions should be back to normal with no warning chimes, proper wiper functions, and the Direct Select operating normally.

Well-trained technicians who repair Mercedes-Benz vehicles using the XENTRY system with WIS have a clear advantage and have access to critical programming and adaptations. |

# Mercedes-Benz Mobil 1

Product Name	Part Number	Quantity	Product Description	Recommended Consumer App.
Mercedes-Benz SPEC.				
Mobil 1 Formula M 5W-40	BQ 1 09 0197	Bulk - No Equipment	Fully synthetic formulas designed specifically for gasoline passenger cars	Low SPASh. Available at most M-B dealers
	BQ 1 09 0195	6/1 Quart Cases		
	BQ 1 09 0196	55 Gallon Drum		
Mercedes-Benz GEO 229.5 5W-40	A000989790211BIFU	Liter	Fully Synthetic formula specifically designed for Mercedes-Benz engines that require the 229.5 Specification	Mercedes-Benz Engines that require 229.5 Specification Oil
	A000989790217BIFU	208 Liter		
	A000989790219BIFU	Bulk - No Equipment		
Mercedes-Benz High Performance EO 229.5 0W-40	A000989810211BIBU	Liter 5KG	Fully Synthetic formula specifically designed for Mercedes-Benz AMG engines that require the 229.5 Specification	Mercedes-Benz Engines that require 229.5 Specification Oil
	A000989810217BIBU	208 Liter 15KG		
Mercedes-Benz GEO 229.6 5W-30	A000989820211BJEU	Liter 40KG	Fully Synthetic formula specifically designed for Mercedes-Benz engines that require the 229.6 Specification	Mercedes-Benz Engines that require 229.6 Specification Oil
	A000989800217BJEU	208 Liter 20KG		
Mercedes-Benz GEO 229.71 0W-20	A000989830211BNXU	Liter 35KG	Fully Synthetic formula specifically designed for Mercedes-Benz engines that require the 229.71 Specification	Mercedes-Benz Engines that require 229.71 Specification Oil
	A000989830217BNXU	208 Liter 15KG		
Mobil 1 0W-40	BQ 1 09 0010	Bulk - No Equipment	Fully synthetic formulation designed to meet the requirements of many European vehicles	Porsche A40. Many European vehicles. HT/TS applications.
	BQ 1 09 0015	6/1 Quart Cases		
	BQ 1 09 0016	55 Gallon Drum		
Mobil 1 ESP X1 0W-30	BQ 1 09 0184	Bulk - No Equipment	Advanced full synthetic formulas designed specifically for diesel passenger cars that have particulate filters	Low SPASh. Available at most MB dealers
	BQ 1 09 0182	6/1 Quart Cases		
	BQ 1 09 0183	55 Gallon Drum		
Mercedes-Benz GEO 229.52 5W30	A000989800219BMEU	Bulk - No Equipment	Fully Synthetic formula specifically designed for Mercedes-Benz engines that require the 229.51 and 229.52 Specification requirements	Mercedes-Benz Engines that require 229.51 Specification Oil
	A000989800211BMEU	Liter 170KG		
	A000989800217BMEU	208 Liter 50KG		
Mobil 1 5W-50	BQ 1 09 0133	16 Gallon Keg	Higher viscosity, advanced full synthetic formula designed for performance vehicles	Porsche A40. HT/HS applications.
	BQ 1 09 0194	6/1 Quart Cases		
Mobil ATF 134	BQ 1 09 0166	55 Gallon Drum	Extra high performance automatic transmission fluid formulated with selected HVI base oils	Recommended for use in Mercedes-Benz automatic gearboxes
Mobil 1 ESP Formula MB 5W-30	BQ 1 09 0165	12x1 Liter Cases	Advanced full synthetic formulas designed specifically for passenger car diesels that have particulate filters	Low SPASh. Available at most MB dealers.
AdBlue® 1/2 Gal.	A 000 583 0107	1/2 Gallon Bottle	Non-toxic solution that transforms harmful Nitrogen Oxide (NOx) emissions from diesel-powered vehicles into harmless water vapor and nitrogen	Recommended for use in Mercedes-Benz, Volkswagen + BMW AdBlue® (DEF) applications
Diesel Exhaust Fluid 55 Gal	BQ 1 47 0002	55 Gallon Drum		
Mobil 1 5W-30	BQ 1 09 0017	6/1 Quart Cases	Advanced full synthetic formulation designed to meet the requirements of many domestic, including GM, and imported vehicles	Vehicles that require 5W-30. Corvette approved.
	BQ 1 09 0018	55 Gallon Drum		
Mobil 1 10W-30	BQ 1 09 0019	6/1 Quart Cases	Advanced full synthetic formula designed for domestics and imports	Vehicles that require 5W-30 or 10W-30
	BQ 1 09 0020	16 Gallon Keg		
	BQ 1 09 0021	55 Gallon Drum		
Mobil 1 5W-20	BQ 1 09 0083	6/1 Quart Cases	Advanced full synthetic formulation designed to meet the requirements of many newer vehicles including Hondas, Fords, Chryslers, and newer Toyotas	Vehicles that require 5W-20
	BQ 1 09 0084	55 Gallon Drum		
Mobil 1 0W-20 AFE	BQ 1 09 0169	6/1 Quart Cases	Advanced full synthetic formulation designed for enhanced fuel economy and cold weather performance	Most vehicles that specify 0W-20 (newer Toyotas and Hondas), 5W-20 and certain hybrids
	BQ 1 09 0168	55 Gallon Drum		
Mobil 1 0W-30 AFE	BQ 1 09 0174	6/1 Quart Cases	Advanced full synthetic formulation designed for enhanced fuel economy and cold weather performance	Most vehicles that specify 5W-30 or 10W-30
Mobil 1 Synthetic ATF	BQ 1 09 0164	6/1 Quart Cases	Multi-vehicle, fully synthetic fluid designed to meet the demanding requirements of modern passenger vehicles	Vehicles that require Dexron III, Ford Mercon and Mercon V performance levels
	BQ 1 09 0163	55 Gallon Drum		



Mercedes-Benz automobiles are designed to perform on the most challenging roads and conditions. Shouldn't the oil used in Mercedes-Benz engines do the same? We think so.

That's why Mercedes-Benz and Mobil 1 have partnered to offer an unbeatable combination of total engine performance and driving luxury.

Please have a look at our oil portfolio which is available through your local Mercedes-Benz dealer. Our dealers are able to offer you a wide variety of oil grades at competitive prices.



Product Name	Part Number	Quantity	Product Description	Recommended Consumer App.
Mercedes-Benz SPEC.				
Mobil 1 15W-50	BQ 1 09 0023	55 Gallon Drum	Boosted, higher viscosity, advanced full synthetic formula designed for performance vehicles	HT/HS applications. Racing and Flat tappet applications
	BQ 1 09 0022	6/1 Quart Cases		
Mobil 1 Gear Oil (Mobil 1 Gear Lube 75W-90)	BQ 1 09 0085	12/1 Quart Cases	Exceeds the most severe service requirements in both conventional and limited slip applications	SUITABLE for use in modern high performance automobiles like SUV's, Vans and Light duty trucks requiring API GL-5 level performance
Mobil Special 5W-30	BQ 1 09 002464	Bulk - No Equipment	Formulated from quality base stocks combined with modern performance additives to give the engine the expected protection and performance under a wide variety of operating conditions	Recommended for gasoline fueled automobiles and light duty trucks requiring an API SN/SM/SL/SJ
	BQ 1 09 0171	12/1 Quart Cases		
	BQ 1 09 003064	55 Gallon Drum		
Mobil Special 10W-30	BQ 1 09 003164	Bulk - No Equipment	Formulated from quality base stocks combined with modern performance additives to give the engine the expected protection and performance under a wide variety of operating conditions	Recommended for gasoline fueled automobiles and light duty trucks requiring an API SN/SM/SL/SJ
	BQ 1 09 0172	12/1 Quart Cases		
	BQ 1 09 003764	55 Gallon Drum		
Mobil Special 10W-40	BQ 1 09 003864	Bulk - No Equipment	Formulated from quality base stocks combined with modern performance additives to give the engine the expected protection and performance under a wide variety of operating conditions	Recommended for gasoline fueled automobiles and light duty trucks where a higher viscosity API SN/SMSL/SJ oil is preferred or recommended
	BQ 1 09 0173	12/1 Quart Cases		
	BQ 1 09 004464	55 Gallon Drum		
Mobil Special 5W-20	BQ 1 09 012464	Bulk - No Equipment	Formulated from quality base stocks combined with modern performance additives to give the engine the expected protection and performance under a wide variety of operating conditions	Recommended for gasoline fueled automobiles and light duty trucks requiring an API SN/SM/SL/SJ
	BQ 1 09 0170	12/1 Quart Cases		
	BQ 1 09 013264	55 Gallon Drum		
Mobil Special 20W-50	BQ 1 09 004664	55 Gallon Drum	Formulated from quality base stocks combined with modern performance additives to give the engine the expected protection and performance under a wide variety of operating conditions	Recommended for gasoline fueled automobiles and light duty trucks where a higher viscosity API SN/SMSL/SJ oil is preferred or recommended
Mobil Delvac 1300 Super 15W-40	BQ 1 09 0053	Bulk - No Equipment	Extra high performance diesel engine oils that help extend engine life in the most severe on and off-highway applications while delivering outstanding performance in modern, high-output, low-emission engines including those with Exhaust Gas Recirculation (EGR) and Aftertreatment Systems with Diesel Particulate Filters (DPFs) and Diesel Oxidation Catalysts (DOCs)	Specifically recommended for the latest low-emissions, high performance diesel applications equipped with aftertreatment systems using Diesel Particulate Filter (DPF) and Diesel Oxidation Catalyst (DOC) technologies
	BQ 1 09 0058	12/1 Quart Cases		
	BQ 1 09 0059	4/1 Gallon Cases		
	BQ 1 09 0060	55 Gallon Drum		
	BQ 1 09 0179	6/1 Quart Cases		
Mobil Delvac 1300 Super 10W-30	BQ 1 09 0086	Bulk - No Equipment		
Mobil Delvac 1 5W-40	BQ 1 09 0051	4/1 Gallon Cases	Fully synthetic supreme performance heavy duty diesel engine oil that helps extend engine life while providing long drain capability and fuel economy for modern diesel engines operating in severe applications	Recommended for use in all super high performance diesel applications, including modern low emission engine designs with Exhaust Gas Recirculation (EGR)
	BQ 1 09 0052	55 Gallon Drum		
Mobil Grease XHP 222	BQ 1 09 0078	60/14 oz Cartridge	Formulated to provide excellent high temperature performance with superb adhesion, structural stability and resistance to water contamination	Recommended for industrial and marine applications, chassis components and farm equipment
	BQ 1 09 0079	120 lb Keg		
	BQ 1 09 0080	400 lb Drum		
	BQ 1 09 0098	40/14 oz Cartridge		
Mobil Lube HD Plus 80W-90	BQ 1 09 0096	120 lb Keg	Extra high performance, automotive lubricant formulated from select base oils and an advanced additive system specifically for limited-slip differentials	Recommended for use in limited-slip differentials, axles, and final drives requiring API GL-5 level performance
	BQ 1 09 0097	400 lb Drum		

## In Pursuit of Parts Perfection

It is well known throughout the industry that Mercedes-Benz has an outstanding record of order fill and quality parts via the dealership parts departments. This is due largely to the fact that most parts are ordered based on the vehicle's VIN, which is a highly accurate basis for ordering.



Al DiFranco

Yet there can be the occasional case when a part may have been superseded, a running change may have occurred, or an improved replacement part made available. There are also cases where parts are needed for an older model Mercedes-Benz, and even the very rare instance of a mislabeled or mispackaged part.

Enter Al DiFranco.

Based out of MBUSA's Atlanta headquarters, Al heads up the 13-person Parts Assistance Center. This group of highly-trained parts specialists is the go-to team when a parts professional at a Mercedes-Benz dealership has any kind of parts question – whether it be related to application, fitment, availability, or technical data about a particular part. This Parts Assistance Center is of particular value to owners and technicians at independent repair shops who can, via their local dealership parts professional, glean all the information they need to purchase the correct part and quickly satisfy their customers' needs.

And Al is just the right guy for the job. His entire 17-year career has been within the Mercedes-Benz family, having started as a dealership valet shuffling customers' cars, quickly becoming a lane technician performing speedy yet important services like replacing light bulbs and wiper blades. His penchant for hustle quickly led him into increasingly responsible jobs within the MBUSA family, including parts warranty, training, and, ultimately, Supervisor of the Parts Assistance Center.

The PAC handles most parts inquiries via telephone from dealership parts departments, providing definitive answers or resolution of issues during the first phone call nearly 90 percent of the time, most often with the first agent who takes the call. If for some unusual reason the first agent is not able to resolve the matter, the call is referred directly to a Level 2 specialist who has access to comprehensive engineering data and also direct and immediate access to resources in Germany. Some issues are simple, some are complex, but virtually all are answered to the satisfaction of the dealership making the call and its ISP wholesale customer.

The PAC has a laser focus on parts issues, not on service procedures. Yet the PAC can be a valuable resource, as agents do have access to technical service bulletins and other resources that can save repair shops time and money. For instance, a wholesale customer may request a COMAND head unit for a 2012 or newer vehicle and the dealership parts person might have trouble specifying it, so he or she could escalate this case. PAC agents are familiar with a technical bulletin that can actually solve many COMAND problems with a simple software update, eliminating the time and expense of replacing the entire head unit. If necessary, the agent can immediately email the relevant bulletin to the inquiring dealership parts professional.

DiFranco thrives on being a problem solver. His motto? "We play to win." |



# Mercedes-Benz StarParts

New Parts Line Launched

## The all-new StarParts line from Mercedes-Benz offers ISPs competitive pricing and enhanced profit margins

There's no denying the high quality, precise fit and value of Genuine Mercedes-Benz replacement parts. But independent repair shops sometimes find themselves in a quandary when sourcing common replacement parts for older-model Mercedes-Benz vehicles. Their local auto parts chains typically offer an alternative line of common service parts at reduced prices, tempting shop owners and technicians to choose them even though they may not match the performance of OE parts.

Now, independent repair and collision shops have an exciting and brand-new option – Mercedes-Benz StarParts.

StarParts is an innovative line of all-new replacement parts for popular Mercedes-Benz vehicles five years old and older. This new line offers common service parts like brake pads and rotors, spark plugs, and other components. This new parts offer allows shop owners to provide their customers with Mercedes-Benz quality at a cost that is more price-friendly, considering the age of the vehicle.

How did they do it? Using new production techniques and alternative materials, standardization of certain design and manufacturing criteria, economies of scale and consolidation. Combined, these factors allow Mercedes-Benz to offer quality, fit, and durability while reducing manufacturing costs. Furthermore, by offering the most commonly-used replacement parts, distribution can be streamlined for further cost reductions.

Wiper blades are a good example. StarParts wiper blades come without a wear indicator, a small concession considering that worn wiper blades typically become self-apparent. Also, Mercedes-Benz engineers were able to

develop commonalities that allow some wiper blades to fit multiple applications, increasing quantities with attendant lower unit costs.

The new StarParts line includes the previously-mentioned brake pads, rotors, and wiper blades, as well as engine oil filters and cabin air filters, and spark plugs — the very parts most often replaced in the repair shop. StarParts are made for a wide range of models. Designed for high-volume model series, StarParts are available for the following vehicles:

- C-Class (W/S203 and W204)
- E-Class (W/S211)
- ML (W164)
- GLK (X204)
- SLK (R171)
- CLS (C219)
- GL (X164)
- R-Class (W251)

As model lines age, more model series will be added on a regular basis.

All StarParts meet and exceed standards set by Mercedes-Benz as well as all legal requirements, so they can be installed with confidence. And this confidence is bolstered by the fact that StarParts protects you with a one-year warranty that covers both parts and labor.

As you would expect, StarParts can be purchased through your local authorized Mercedes-Benz dealership parts department. StarParts feature their own brand design, labelling and packaging, and part numbers characterized by the “90” or “95” suffix.

The introduction of this new, second line of parts will have no impact on the continued availability of quality Mercedes-Benz remanufactured parts.

## So why StarParts?

- Affords motorists Mercedes-Benz quality parts tailored to the age, condition, and value of their vehicles.
- Makes continued ownership even more viable while enhancing resale value.
- Allows independent repair shops to offer their customers more affordable options.
- Provides a greater profit margin for the ISP.
- Eliminates the need for ISPs to shop elsewhere for their Mercedes-Benz replacement parts.
- Provides confidence for the technician and shop owner not available with inferior “white box” parts.
- Enhances the image of the repair shop by allowing it to offer parts designed and distributed by Mercedes-Benz.

The new line of Mercedes-Benz StarParts will be constantly developed, as new products are added and newer models reach the five-year mark. |



## StarParts is a parts line for Mercedes-Benz vehicles 5 years and older, which is:

- Built for high functionality and fit
- Backed by a one-year warranty\* that includes parts and labor
- Designed to enhance margins and help grow profits for your shop in the long run

**To order StarParts, contact your Mercedes-Benz dealership today.**



Mercedes-Benz  
StarParts

## Introducing Mercedes-Benz StarParts

An authentic parts option—at exceptional prices.







Economy Brand Wiper Blades



Genuine Mercedes-Benz Wiper Blades

Some think all wiper blades are the same.  
This will make it clear.

**Genuine Mercedes-Benz Wiper Blades can provide up to 800,000 more wiping cycles than ordinary blades\*.** Not to mention that every blade has a precise curvature unique to each model, and most have a maintenance indicator on the tip that shows when replacement is necessary. A clear advantage — at a competitive price. This is why you should choose Genuine Mercedes-Benz Wiper Blades. **Contact an authorized Mercedes-Benz dealer or learn more at [www.mbwholesaleparts.com](http://www.mbwholesaleparts.com).**

\*As compared to economy wiper blades using durability test #PN 103713, which tests wiper durability through 1.5 million wiping cycles.

MSRP  
**\$62**

Part #  
A 212 820 19 00



Mercedes-Benz  
The best or nothing.

