



Subaru Battery/Alternator Service

This winter has put an extra strain on your customers' starters, batteries and alternators. Some may be driving around with an old, crusty, neglected battery, like the one in the photo above. If, or when, a battery like this fails, it will be up to you to determine whether the battery simply died of old age, or whether other problems with the starting or charging system have contributed to the failure. In this article, we'll discuss battery and alternator construction, then cover diagnostic techniques for both components.

Battery Construction

The automotive battery is an electrochemical device that stores and converts chemical energy into electrical energy. It is not a storage container for electricity. The battery provides the initial electrical energy for the ignition system and starting system. It also supplies additional current when the current demand of the system exceeds the output of the alternator.

Automotive batteries normally have six cells. Each cell produces 2.1 volts; thus a six-cell battery produces 12.6 volts. The voltage output of the battery

is determined by the material used in the construction of the plates.

Automotive battery plates are made of two dissimilar materials; for example lead peroxide (positive plate) and sponge lead (negative plate). A thin separator of rubber or plastic is inserted between each negative and positive plate.

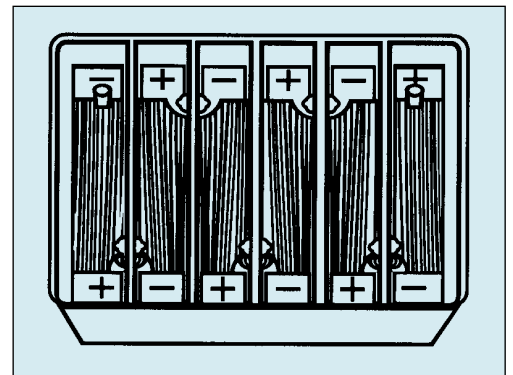

Battery Cell Construction

The cells are then connected in series, i.e., the positive plates of one cell are connected to the negative plates of the next cell, etc. Note that additional plates in a cell do not increase the voltage capability of the

cell or battery, but they do increase the length of time that the battery can produce electricity (ampere rating).

Electrolyte is the final ingredient required for an active battery. Without electrolyte, a battery is inactive and does not produce electricity. Electrolyte is a solution of water and purified sulfuric acid which allows the chemical reaction to occur between the plates. Generally, the percentage of sulfuric acid in a battery is 36 percent by weight and 25 percent by volume.

To determine the amount of charge of a battery, the specific gravity of the electrolyte is measured. A fully charged battery theoretically should have an electrolyte specific gravity of 1.299. However, a normally charged battery will most likely indicate specific gravity readings ranging from 1.260 to 1.280 at 80° F.

Specific gravity is the ratio of the weight (or mass) of the water to the weight (or mass) of the sulfuric acid. Thus, a specific gravity of 1.000 is equal to water. Specific gravity will change with changes in temperature of the electrolyte. For each 10° above 80° F, add .004 to the electrolyte reading. For each 10° below 80° F., subtract .004 from the electrolyte reading. Or you may use an electrolyte temperature correction chart or a temperature equipped hydrometer.

Note: The specific gravity readings must not vary more than 50 points between cells. A variation of more than 50 points indicates cell deterioration, and a need for battery replacement.

Preliminary Battery Testing

The first step is to check the operation of the electrical components. Then complete the following checks:

- Check the battery for damage
- Check the positive and negative leads for corrosion and proper installation.
- Check that the electrolyte is at the full level indicator(s).
- Check the color of the electrolyte. Clear means there is no damage. Red means there is positive plate deterioration. Gray means there is negative plate deterioration.
- Check the specific gravity. There should be no more than a maximum of a 50 point differential between the cells.
- On sealed maintenance free batteries, check the open circuit voltage and compare its value with the manufacturer's specifications.
- If the specific gravity is below 1.230 or the open circuit voltage is below the recommended value, charge the battery and recheck the specific gravity/open circuit voltage.

Subaru Battery/Alternator Service

Visual Inspection

To avoid wasting time on a battery that has external damage, check the following before proceeding:

- Inspect the battery exterior for damage or cracks.
- Inspect for loose or broken terminals.
- Inspect for the cause of the battery damage.

Important: Replace the damaged battery, only after the cause has been determined and eliminated.

Comprehensive Battery Testing

The most accurate means of checking the state of charge of a lead acid and/or maintenance-free battery is by measuring the specific gravity of its electrolyte. This can be accomplished by using a good quality battery hydrometer. The hydrometer should be the hydrometer-thermometer type, which allows the user to adjust the observed specific gravity reading based on the temperature of the electrolyte.

The specific gravity range for state of charge is:

- 1.265 to 1.299 = Full Charge
- 1.235 to 1.265 = $\frac{3}{4}$ Charge
- 1.205 to 1.235 = $\frac{1}{2}$ Charge
- 1.170 to 1.205 = $\frac{1}{4}$ Charge
- 1.140 to 1.170 = Barely Operable
- 1.110 to 1.140 = Completely Discharged

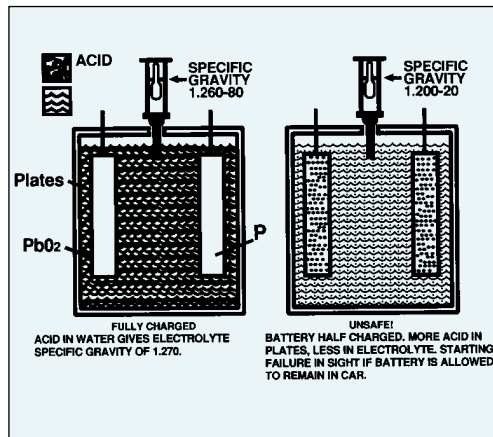

Measuring Specific Gravity

State of Charge Check

To check the battery's state of charge:

- Connect a digital voltmeter across the battery terminals. Read the voltage with

no current flowing.

- If the voltage is less than 12.45 volts, charge the battery.
- If the voltage is 12.45 volts or higher, check for a possible surface charge. Batteries charged or used in a vehicle within the last 24 hours must have the surface charge removed.
- To remove the surface charge, connect a carbon pile load tester (such as Sun VAT 40) across the battery terminals and apply a load equal to $\frac{1}{2}$ the cold cranking amp (CCA) rating of the battery for 15 seconds.



Battery Load Tester

- Read the battery terminal voltage again. If it is still 12.45 volts or above, proceed with the load test.
- If not, charge the battery.
- Verify that electrolyte is above the top of the plates in each cell prior to charging or load testing. If the electrolyte is below the plates, the battery may explode if it is charged or load tested. If the electrolyte is low, add distilled water to the cell(s) to bring them to the proper level as indicated on the battery case.

The proper test of specific gravity involves checking each of the cells in a battery in comparison to one another. If, after fully charging the battery, one or more cells vary from the remaining cells by 0.050 or more, the battery should be replaced. Be certain that the float in the hydrometer floats freely while taking these readings.

In some instances it may not be advisable or possible to use this method to check the battery state of charge. This would include when the battery is still in the car (risking acid

Subaru Battery/Alternator Service

spills), or when the battery has non-removable vent caps. In these cases, an approximation of specific gravity can be obtained using a digital voltmeter. Connect the voltmeter across the battery terminals. Read this terminal voltage or open circuit voltage (OCV) with no current flowing. The numerical value of this open circuit voltage is 0.84 higher than the numerical value of the specific gravity.



Battery Open Circuit Voltage

Example: A battery is found to have a 12.66 terminal voltage (OCV).

12.66 divided by 6 cells = 2.11 volts per cell.

2.11 Volts per Cell - .84 Conversion Factor 1.27 = 1.270 Specific Gravity (approx.).

This information is useful to determine if the battery is sufficiently charged to load test and, if necessary, how long and at what charge rate it should be charged.

Note: The OCV method is an approximation. Actual hydrometer readings should always be used when possible. Keep in mind that specific gravity affects the freezing point of the battery. This relationship is as follows:

Specific Gravity	Freezing Point
1.280	-90° F
1.250	-62° F
1.200	-15° F
1.150	+5° F
1.100	+19° F
1.050	+27° F

This is especially important for vehicles stored in cold climates. A battery with a very low charge can freeze at +27° F, compared to a ¾ charged battery at -62° F.

Battery Load Test

The surface charge must be removed before proceeding with load test. Refer to State of Charge Check above.

- Attach a variable carbon pile load test to the battery terminals.
- Apply a load test value of ½ the cold cranking amps (CCA) rating.
- At 15 seconds, read the battery terminal voltage, then turn off the load.
- Determine the battery temperature by touch and compare the voltage reading with the load test table.
- If the voltage is less than the table, replace the battery. If the voltage is equal to or greater than the accepted value, return the battery to service.

Load Test Table

Acceptable Voltage	Ambient Temp.
9.6	70° F & Above
9.4	50° F
9.1	30° F
8.8	15° F
8.5	0° F
8.0	Below 0° F

Charging Information Single Battery Charging

The battery charger should be capable of delivering at least a 60 amp rate of charge with an adjustable charge rate.

- Connect the battery to the charger.
- Connect the charger to a power source.
- Set the charger to the high setting and charge the battery.
- Monitor the battery hourly for spewing, gassing or heat above 125° F. If this occurs and charging voltage is 16 volts or below, replace the battery. If over 16 volts, allow the battery to cool, then resume charging at a reduced rate to avoid these conditions.
- Check charge acceptance hourly. If voltage is below 16 volts, continue charging. If it is 16 volts or above, check the charge rate in amperes. If it is

Subaru Battery/Alternator Service

5 amperes or above, continue charging. If it is below 5 amperes, the battery is sufficiently charged.

- Unplug the charger, then disconnect it from the battery.
- Remove the surface charge. See State of Charge Check above.
- Load test the battery.

Important: Age, capacity, state of charge and battery types vary. Closely monitor batteries during any charging procedure.

Important: Clean all terminals and make sure all electrical connections are tight.

Important: Batteries should be charged at room temperature. After charging a battery, follow the load test procedure.

If a battery has been discharged and remains uncharged for a long period of time, it will be necessary to first remove sulfation from the battery plates. Apply a high rate of charge (30 amps) for 1 to 1½ hours, observing the precautions above. Following this, apply approximately a 6 amp charge until three successive specific gravity checks at one hour intervals reveal no increase in specific gravity readings. This procedure may take up 24 hours to complete with a 6 amp charger).

Weak Battery Diagnosis

- Check for damage.
- Check the positive and negative leads for damage.
- Check the electrolyte level and specific gravity.
- Check the alternator belt tightness.
- Check the charging system wires and connections for damage.

A battery performance test is required when the engine cranks slowly or does not start. If the battery specific gravity is greater than 1.230, conduct a battery performance test. If the specific gravity is less than 1.230, charge the battery in accordance with the manufacturer's recommended procedures. Then proceed with a battery performance test.

Note: When conducting a battery performance test, always follow the equip-

ment manufacturer's recommended procedures. Apply a load equal to ½ the cold cranking amp rating of the battery for 15 seconds. Observe the battery voltage while the load is being applied and compare it with the manufacturers' specifications.

Alternator Construction

The components of a Subaru alternator are:

- Pulley
- Front Cover/Bearing
- Rotor (Field Coil)
- Stator
- Voltage Regulator
- Brush Assembly
- Rectifier
- Rear Cover/Bearing
- Cooling fan

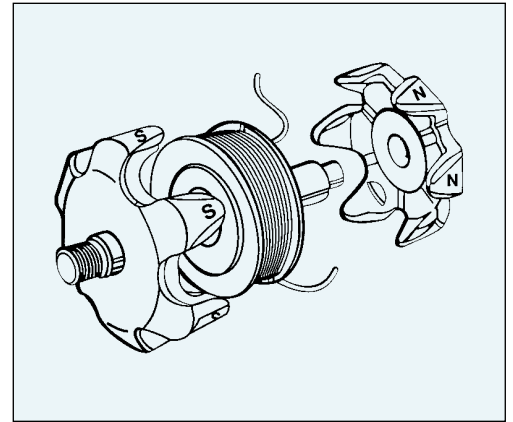

Alternator Rotor Assembly

Because the field winding (rotor assembly) is lighter in weight and therefore easier to rotate, it rotates inside a stationary stator. Alternating north and south magnetic fields are created by bending the front and rear plates over the coil in a star-shaped interwoven type pattern.

The standard stator design is a three phase "Y" configuration with three coils connected at one end. The coil of the "Y" are spaced at 120 degree intervals. Full wave rectification is accomplished through the use of six diodes, (three positive and three negative). As the field coil rotates, current is induced into each stator winding, charging the winding. Negative (-) and positive (+) polarities are created at the ends of the stator winding. Each stator winding end is connected to a respective diode

Subaru Battery/Alternator Service

in the rectifier assembly. The charge in each winding causes the diode to allow charging current to flow to the battery for that period of rotation only. As the field continues to rotate, it sequentially charges the remaining stator windings, causing their respective diodes to allow charging current to flow to the battery.

Four phase rectification incorporates a fourth winding which spaces the windings at 90 degree intervals. Four phase units use 8 silicon diodes, (four positive and four negative). The advantages of four phase rectification are an increase in current output and a reduction of ripple voltage output.

The capacitor maintains stator voltage between phases by charging at peak voltage and discharging as the phase voltage drops. This has the effect of smoothing the “ripple” voltage produced by the phases of the alternator. The capacitor also reduces radio frequency interference (RFI).

Solid State Voltage Regulator

The internal solid state type of voltage regulator controls voltage within a specified range (usually 14.1 to 14.8 volts). The regulator provides an ON and OFF voltage pattern to the field coil. The field coil is turned OFF by the regulator when the battery voltage reaches a preset level. This stops the alternator from charging. When the battery voltage drops below the preset level, the regulator charges the field coil to the maximum. The ON and OFF threshold level is determined by a zener diode that is incorporated into the regulator assembly.

Alternator Testing Precautions

Observe the following precautions when testing an alternator:

- Disconnect all connectors properly.
- Do not ground circuits with tools.
- Never lay tools on the battery.
- Always disconnect the battery prior to alternator replacement.
- Secure loose harness/wiring to prevent damage caused during alternator removal/replacement.
- When full-fielding the alternator, never exceed 16.0 volts. Voltage levels in excess of this specification may cause damage to electrical system com-

ponents.

- Never disconnect the battery during an alternator test.
- An alternator performance test should only be made with a serviceable battery.

Conduct an alternator performance test when any of the following conditions are present:

- The battery is dead (discharged), but holds a charge when charged. Also, the battery performance test indicates a good battery.
- The vehicle voltmeter indicates a discharging condition or the charge warning light is illuminated during normal vehicle operation.

Conduct the alternator performance test in accordance with the operator’s instructions for the test equipment you are using.

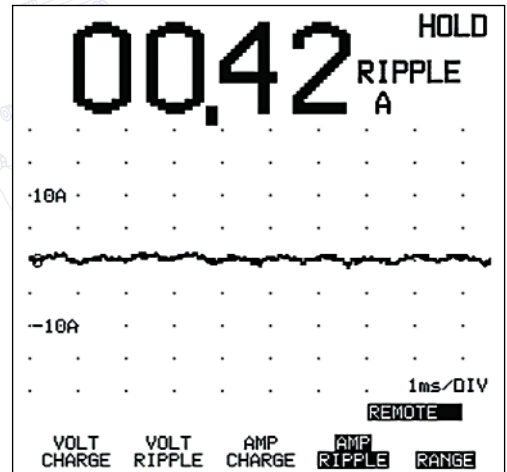

Alternator A/C Ripple Test

Conduct an alternator charging test, a voltage regulator test, and a diode/stator test. Compare the results of the tests to the specifications listed in the appropriate model year Subaru service manual. Repair and or replace components as required.

Conduct a charging system requirements test in accordance with the operator’s instructions for the test equipment you are using. Be sure to connect the D-Check connectors so the fuel pump and other fuel system components operate. After completing the charging system test, restore the D-Check and alternator connections to the normal operating condition.